

DIRECTORATE OF EDUCATION
GNCT of Delhi

SUPPORT MATERIAL
(2023-2024)
Class : X

SCIENCE

Under the Guidance of

Sh. Ashok Kumar
Secretary (Education)

Mr. Himanshu Gupta
Director (Education)

Dr. Rita Sharma
Addl. DE (School & Exam.)

Coordinators

Mr. Sanjay Subhas Kumar
DDE (Exam)

Ms. Ritu Singhal
OSD (Exam)

Dr. Raj Kumar
OSD (Exam)

Mr. Krishan Kumar
OSD (Exam)

Production Team

Anil Kumar Sharma

Published at Delhi Bureau of Text Books, 25/2 Institutional Area, Pankha Road,
New Delhi-110058 by **Rajesh Kumar**, Secretary, Delhi Bureau of Text Books
and Printed by Supreme Offset Press, Greater Noida, U.P.

अशोक कुमार, भा.प्र.से
सचिव (शिक्षा)

ASHOK KUMAR, IAS
Secretary (Education)



राष्ट्रीय राजधानी क्षेत्र, दिल्ली सरकार

पुराना सचिवालय, दिल्ली-110054

दूरभाष : 23890187 टेलीफैक्स: 23890119

Government of National Capital Territory of Delhi

Old Secretariat, Delhi-110054

Phone : 23890187, Telefax : 23890119

e-mail : secyedu@nic.in

D.O. NO. : DE.5/228/Exam/Message/SM

Dated : 24.11.2023 / 2018/1095

Message

"Children are like wet cement, whatever falls on them makes an impression."

Haim Ginott

Embracing the essence of this quote, the Directorate of Education, GNCT of Delhi is unwavering in its commitment to its core mission of delivering high-quality education to all its students. With this objective in mind, DoE annually develops support materials meticulously tailored to suit the learning needs of students from classes IX to XII.

Every year, our expert faculty members shoulder the responsibility of consistently reviewing and updating the Support Material to synchronize it with the latest changes introduced by CBSE. This continuous effort is aimed at empowering students with innovative approaches and techniques, fostering their problem-solving skills and critical thinking abilities. I am confident that this year will be no exception, and the Support Material will greatly contribute to our students' academic success.

The support material is the result of unwavering dedication of our team of subject experts. The Support Material has been specially curated for our students, with the belief that its thoughtful and intelligent utilization will undoubtedly elevate the standards of learning and will continue to empower our students to excel in their examinations.

I wish to congratulate the entire team for their invaluable contribution in creating a highly beneficial and practical Support Material for our students.

I extend my best wishes to all our students for a promising and bright future.

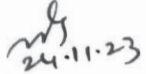
(Ashok Kumar)

HIMANSHU GUPTA, IAS
Director, Education & Sports

No. PS/DE/2023/349
Date: 29/11/2023



Directorate of Education
Govt. of NCT of Delhi
Room No. 12, Civil Lines
Near Vidhan Sabha,
Delhi-110054
Ph.: 011-23890172
E-mail: diredu@nic.in

MESSAGE

It brings me immense pleasure to present the support material for students of classes IX to XII, meticulously crafted by our dedicated subject experts. Directorate of Education is committed to empower educators and students alike by providing these resources free of cost for students of all government and government aided schools of Delhi.

The support material is an appreciable effort to align the content with the latest CBSE patterns. It has been carefully designed as a resource to facilitate the understanding, acquisition and practice of essential skills and competencies outlined in the curriculum.

The core of this support material lies in providing a framework for adopting an analysis-based approach to learning and problem-solving. It aims to prompt educators to reflect on their teaching methodologies and create an interactive pathway between the child and the text.

In the profound words of Dr A.P.J. Abdul Kalam, **“Educationists should build the capacities of the spirit of inquiry, creativity, entrepreneurial and moral leadership among students and become their role model.”**

The journey of education is ongoing; it's the process, not just the outcome, which shapes us. This support material endeavours to be that catalyst of change for each student of Directorate of Education.

Let us embark on this transformative journey together, ensuring that every student feels equipped not only with the knowledge but also, with the skills and mindset to thrive in the 21st century.

I wish you all the best for all your future endeavours.

(HIMANSHU GUPTA)

Dr. RITA SHARMA
Additional Director of Education
(School/Exam)



सत्यमेव जयते

Govt. of NCT of Delhi
Directorate of Education
Old Secretariat, Delhi-110054
Ph.: 23890185

D.O. No. DE.:5/22.8/Exam/Mexay/SH/
2013/1096
Dated:24.11.2023.....

MESSAGE

The persistent efforts of the Directorate in making the course material more accessible and student-friendly are evident in the conscientious preparation of the Support Material. Our team consistently adapts to the evolving educational landscape, ensuring that the Support Material for the various subjects of classes 9 to 12 align with the latest CBSE guidelines and syllabi prescribed for the annual examinations.

The Support Material encapsulates crucial subject-specific points and facts, tailored to suit the students, all presented in a lucid language. It is our firm belief that these resources will significantly augment the academic prowess of our students, empowering them to excel in their upcoming examinations.

I extend my heartfelt congratulations to the diligent officials and teachers whose dedication and expertise have played a pivotal role in crafting this invaluable content/resource.

I convey my best wishes to all our students for a future brimming with success. Remember, every page you read is a step towards an enlightened tomorrow.

Rita Sharma

(Dr Rita Sharma)

DIRECTORATE OF EDUCATION
Govt. of NCT, Delhi

SUPPORT MATERIAL
(2023-2024)

SCIENCE
Class : X
(English Medium)

NOT FOR SALE

PUBLISHED BY : DELHI BUREAU OF TEXTBOOKS

भारत का संविधान

उद्देशिका

हम, भारत के लोग, भारत को एक ¹[संपूर्ण प्रभुत्व-संपन्न समाजवादी पंथनिरपेक्ष लोकतंत्रात्मक गणराज्य] बनाने के लिए, तथा उसके समस्त नागरिकों को :

सामाजिक, आर्थिक और राजनैतिक न्याय,

विचार, अभिव्यक्ति, विश्वास, धर्म

और उपासना की स्वतंत्रता,

प्रतिष्ठा और अवसर की समता

प्राप्त कराने के लिए,

तथा उन सब में

व्यक्ति की गरिमा और ²[राष्ट्र की एकता

और अखंडता] सुनिश्चित करने वाली बंधुता

बढ़ाने के लिए

दृढ़संकल्प होकर अपनी इस संविधान सभा में आज तारीख 26 नवंबर, 1949 ई. को एतद्वारा इस संविधान को अंगीकृत, अधिनियमित और आत्मार्पित करते हैं।

1. संविधान (बयालीसवां संशोधन) अधिनियम, 1976 की धारा 2 द्वारा (3.1.1977 से) "प्रभुत्व-संपन्न लोकतंत्रात्मक गणराज्य" के स्थान पर प्रतिस्थापित।
2. संविधान (बयालीसवां संशोधन) अधिनियम, 1976 की धारा 2 द्वारा (3.1.1977 से) "राष्ट्र की एकता" के स्थान पर प्रतिस्थापित।

THE CONSTITUTION OF INDIA

PREAMBLE

WE, THE PEOPLE OF INDIA, having solemnly resolved to constitute India into a ¹**[SOVEREIGN SOCIALIST SECULAR DEMOCRATIC REPUBLIC]** and to secure to all its citizens :

JUSTICE, social, economic and political;

LIBERTY of thought, expression, belief, faith and worship;

EQUALITY of status and of opportunity; and to promote among them all

FRATERNITY assuring the dignity of the individual and the ²[unity and integrity of the Nation];

IN OUR CONSTITUENT ASSEMBLY this twenty-sixth day of November, 1949 do **HEREBY ADOPT, ENACT AND GIVE TO OURSELVES THIS CONSTITUTION.**

1. Subs. by the Constitution (Forty-second Amendment) Act, 1976, Sec.2, for "Sovereign Democratic Republic" (w.e.f. 3.1.1977)
2. Subs. by the Constitution (Forty-second Amendment) Act, 1976, Sec.2, for "Unity of the Nation" (w.e.f. 3.1.1977)

भारत का संविधान

भाग 4क

नागरिकों के मूल कर्तव्य

अनुच्छेद 51 क

मूल कर्तव्य - भारत के प्रत्येक नागरिक का यह कर्तव्य होगा कि वह -

- (क) संविधान का पालन करे और उसके आदर्शों, संस्थाओं, राष्ट्रध्वज और राष्ट्रगान का आदर करे;
- (ख) स्वतंत्रता के लिए हमारे राष्ट्रीय आंदोलन को प्रेरित करने वाले उच्च आदर्शों को हृदय में संजोए रखे और उनका पालन करे;
- (ग) भारत की संप्रभुता, एकता और अखंडता की रक्षा करे और उसे अक्षुण्ण बनाए रखे;
- (घ) देश की रक्षा करे और आह्वान किए जाने पर राष्ट्र की सेवा करे;
- (ङ) भारत के सभी लोगों में समरसता और समान भ्रातृत्व की भावना का निर्माण करे जो धर्म, भाषा और प्रदेश या वर्ग पर आधारित सभी भेदभावों से परे हो, ऐसी प्रथाओं का त्याग करे जो महिलाओं के सम्मान के विरुद्ध हों;
- (च) हमारी सामासिक संस्कृति की गौरवशाली परंपरा का महत्त्व समझे और उसका परिरक्षण करे;
- (छ) प्राकृतिक पर्यावरण की, जिसके अंतर्गत वन, झील, नदी और वन्य जीव हैं, रक्षा करे और उसका संवर्धन करे तथा प्राणिमात्र के प्रति दयाभाव रखे;
- (ज) वैज्ञानिक दृष्टिकोण, मानववाद और ज्ञानार्जन तथा सुधार की भावना का विकास करे;
- (झ) सार्वजनिक संपत्ति को सुरक्षित रखे और हिंसा से दूर रहे;
- (ञ) व्यक्तिगत और सामूहिक गतिविधियों के सभी क्षेत्रों में उत्कर्ष की ओर बढ़ने का सतत् प्रयास करे, जिससे राष्ट्र निरंतर बढ़ते हुए प्रयत्न और उपलब्धि की नई ऊँचाइयों को छू सके; और
- (ट) यदि माता-पिता या संरक्षक हैं, छह वर्ष से चौदह वर्ष तक की आयु वाले अपने, यथास्थिति, बालक या प्रतिपाल्य को शिक्षा के अवसर प्रदान करे।



Constitution of India

Part IV A (Article 51 A)

Fundamental Duties

It shall be the duty of every citizen of India —

- (a) to abide by the Constitution and respect its ideals and institutions, the National Flag and the National Anthem;
- (b) to cherish and follow the noble ideals which inspired our national struggle for freedom;
- (c) to uphold and protect the sovereignty, unity and integrity of India;
- (d) to defend the country and render national service when called upon to do so;
- (e) to promote harmony and the spirit of common brotherhood amongst all the people of India transcending religious, linguistic and regional or sectional diversities; to renounce practices derogatory to the dignity of women;
- (f) to value and preserve the rich heritage of our composite culture;
- (g) to protect and improve the natural environment including forests, lakes, rivers, wildlife and to have compassion for living creatures;
- (h) to develop the scientific temper, humanism and the spirit of inquiry and reform;
- (i) to safeguard public property and to abjure violence;
- (j) to strive towards excellence in all spheres of individual and collective activity so that the nation constantly rises to higher levels of endeavour and achievement;
- * (k) who is a parent or guardian, to provide opportunities for education to his child or, as the case may be, ward between the age of six and fourteen years.

Note: The Article 51A containing Fundamental Duties was inserted by the Constitution (42nd Amendment) Act, 1976 (with effect from 3 January 1977).

*(k) was inserted by the Constitution (86th Amendment) Act, 2002 (with effect from 1 April 2010).



**Team Members for Preparation/Review
of Support Material-2023-24
Class - X, Science**

S.No.	Name & Designation	Name of School/Branch
1.	Dr. Devender Kumar (Vice-Principal)	GCSSS, C-Block, Metro Vihar
2.	Ms. Yogita Girotra Lecturer	Core Academic Unit, Exam Branch, DoE, Delhi
3.	Mr. Siddharth Kaushik, TGT	, RPVV, Kishan Ganj, Delhi
4.	Ms. Abha Srivastva, TGT	SKV, Burari, Delhi
5.	Ms. Vandana Sharma, TGT	SV(Co.Ed)SSS, Possangi Pur, Janak Puri, Delhi
6.	Shahbat Hussain	Dr. Zakir Hussain Memo. School, Delhi

COURSE STRUCTURE
CLASS X
(Annual Examination)

Marks: 80

Unit No.	Unit	Marks
I	Chemical Substances-Nature and Behaviour	25
II	World of Living	25
III	Natural Phenomena	12
IV	Effects of Current	13
V	Natural Resources	05
Total		80
Internal assessment		20
Grand Total		100

Theme: Materials

Unit I: Chemical Substances - Nature and Behaviour

Chemical reactions: Chemical equation, Balanced chemical equation, implications of a balanced chemical equation, types of chemical reactions: combination, decomposition, displacement, double displacement, precipitation, endothermic exothermic reactions, oxidation and reduction.

Acids, bases and salts: Their definitions in terms of furnishing of H⁺ and OH⁻ ions, General properties, examples and uses, neutralization, concept of pH scale (Definition relating to logarithm not required), importance of pH in everyday life; preparation and uses of Sodium Hydroxide, Bleaching powder, Baking soda. Washing soda and Plaster of Paris.

Metals and Nonmetals: Properties of metals and non-metals; Reactivity series; Formation and properties of ionic compounds; Basic metallurgical processes; Corrosion and its prevention.

Carbon compounds: Covalent bonding in carbon compounds. Versatile nature of carbon. Homologous series. Nomenclature of carbon compounds containing functional groups (halogens, alcohol, ketones, aldehydes, alkanes and alkynes), difference between saturated hydro carbons and unsaturated hydrocarbons.

Chemical properties of carbon compounds (combustion, oxidation, addition and substitution reaction). Ethanol and Ethanoic acid (only properties and uses), soaps and detergents

Theme: The World of the Living Unit II: World of Living

Life processes: 'Living Being'. Basic concept of nutrition, respiration, transport and excretion in plants and animals.

Control and co-ordination in animals and plants: Tropic movements in plants; Introduction of plant hormones; Control and co-ordination in animals: Nervous system; Voluntary, involuntary and reflex action; Chemical co-ordination: animal hormones.

Reproduction: Reproduction in animals and plants (asexual and sexual) reproductive health - need and methods of family planning. Safe sex vs HIV/AIDS. Child bearing and women's health.

Heredity and Evolution: Heredity; Mendel's contribution- Laws for inheritance of traits: Sex determination: brief introduction: (topics excluded-evolution; evolution and classification and evolution should not be equated with progress).

Theme: Natural Phenomena

Unit III: Natural Phenomena

Reflection of light by curved surfaces; Images formed by spherical mirrors, centre of curvature, principal axis, principal focus, focal length, mirror formula (Derivation not required), magnification. Refraction, Laws of refraction, refractive index.

Refraction of light by spherical lens; Image formed by spherical lenses; Lens formula (Derivation not required); Magnification. Power of a lens.

Functioning of a lens in human eye, defects of vision and their corrections, applications of spherical mirrors and lenses.

Refraction of light through a prism, dispersion of light, scattering of light, applications in daily life (excluding colour of the sun at sunrise and sunset).

Theme: How Things Work

Unit IV: Effects of Current

Electric current, potential difference and electric current. Ohm's law; Resistance, Resistivity, Factors on which the resistance of a conductor depends. Series combination of resistors, parallel combination of resistors and its applications in daily life. Heating effect of electric current and its applications in daily life. Electric power, Interrelation between P, V, I and R.

Magnetic effects of current : Magnetic field, field lines, field due to a current carrying conductor, field due to current carrying coil or solenoid; Force on current carrying conductor, Flemings Left Hand Rule, Direct current. Alternating current: frequency of AC. Advantage of AC over DC. Domestic electric circuits.

Theme: Natural Resources

Unit V: Natural Resources

Our environment: Eco-system, Environmental problems. Ozone depletion, waste production and their solutions. Biodegradable and non-biodegradable substances.

Note for the Teachers:

1. The chapter Management of Natural Resources (NCERT Chapter 16) will not be assessed in the year-end examination. However, learners may be assigned to read this chapter and encouraged to prepare a brief write up to any concept of this chapter in their Portfolio. This may be for Internal Assessment and credit may be given Periodic Assessment/Portfolio).
2. The NCERT text books present information in boxes across the book. These help students to get conceptual clarity. However, the information in these boxes would not be assessed in the year-end examination.

PRACTICALS

Practical should be conducted alongside the concepts taught in theory classes

LIST OF EXPERIMENTS

1. A. Finding the pH of the following samples by using pH paper/universal indicator: **Unit-I**
 - (i) Dilute Hydrochloric Acid
 - (ii) Dilute NaOH solution
 - (iii) Dilute Ethanoic Acid solution
 - (iv) Lemon juice
 - (v) Water
 - (vi) Dilute Hydrogen Carbonate solution

- B. Studying the properties of acids and bases (HCl & NaOH) on the basis of their reaction with: **Unit-I**
- a) Litmus solution (Blue/Red)
 - b) Zinc metal
 - c) Solid sodium carbonate
2. Performing and observing the following reactions and classifying them into: **Unit-I**
- A. Combination reaction
 - B. Decomposition reaction
 - C. Displacement reaction
 - D. Double displacement reaction
 - (i) Action of water on quicklime
 - (ii) Action of heat on ferrous sulphate crystals
 - (iii) Iron nails kept in copper sulphate solution
 - (iv) Reaction between sodium sulphate and barium chloride solutions
3. Observing the action of Zn, Fe, Cu and Al metals on the following salt solutions: **Unit-I**
- i) $\text{ZnSO}_4(\text{aq})$
 - ii) $\text{FeSO}_4(\text{aq})$
 - iii) $\text{CuSO}_4(\text{aq})$
 - iv) $\text{Al}_2(\text{SO}_4)_3(\text{aq})$
- Arranging Zn, Fe, Cu and Al (metals) in the decreasing order of reactivity based on the above result.
4. Studying the dependence of potential difference (V) across a resistor on the current (I) passing through it and determine its resistance. Also plotting a graph between V and I. **Unit-IV**
5. Determination of the equivalent resistance of two resistors when connected in series and parallel. **Unit-IV**
6. Preparing a temporary mount of a leaf peel to show stomata. **Unit- II**
7. Experimentally show that carbon dioxide is given out during respiration. **Unit-II**

8. Study of the following properties of acetic acid (ethanoic acid): **Unit-I**
- i) Odour
 - ii) solubility in water
 - iii) effect on litmus
 - iv) reaction with Sodium Hydrogen Carbonate
9. Study of the comparative cleaning capacity of a sample of soap in soft and hard water. **Unit-1**
10. Determination of the focal length of: **Unit-III**
- i) Concave mirror
 - ii) Convex lens
- by obtaining the image of a distant object.
11. Tracing the path of a ray of light passing through a rectangular glass slab for different angles of incidence. Measure the angle of incidence, angle of refraction, angle of emergence and interpret the result. **Unit-III**
12. Studying (a) binary fission in Amoeba, and (b) budding in yeast and Hydra with the help of prepared slides. **Unit-II**
13. Tracing the path of the rays of light through a glass prism. **Unit-III**
14. Identification of the different parts of an embryo of a dicot seed (Pea, gram or red kidney bean). **Unit-II**

PRESCRIBED BOOKS:

Science-Text book for class X- NCERT Publication

Assessment of Practical Skills in Science- Class X- CBSE Publication

Laboratory Manual-Science-Class X, NCERT Publication

Exemplar Problems Class X - NCERT Publication

Theory (80 marks)

Question Paper Design

(Class X)

Subject: Science

Competencies	Total
Demonstrate Knowledge and Understanding	46%
Application of Knowledge/Concepts	22%
Formulate, Analyze, Evaluate and Create	32%
	100%

Note:

- **Typology of Questions:** VSA including objective type questions, Assertion - Reasoning type questions; SA; LA; Source-based/Case-based/ Passage-based/ Integrated assessment questions.
- An internal choice of approximately 33% would be provided.

Internal Assessment (20 Marks)

- **Periodic Assessment** - 05 marks + 05 marks
- **Subject Enrichment** (Practical Work) - 05 marks
- **Portfolio** - 05 marks

Suggestive verbs for various competencies

- **Demonstrate Knowledge and Understanding**
 - o State, name, list, identify, define, suggest, describe, outline, summarize, etc.
- **Application of Knowledge/Concepts**
 - o Calculate, illustrate, show, adapt, explain, distinguish, etc.
- **Formulate, Analyze, Evaluate and Create**
 - o Interpret, analyze, compare, contrast, examine, evaluate, discuss, construct, etc.

Content

<i>S.No.</i>	<i>Chapter Name</i>	<i>Page No.</i>
1.	Chemical Reaction and Equations	01–17
2.	Acids, Bases and Salts	18–39
3.	Metals and Non-metals	40–53
4.	Carbon and its compounds	54–73
5.	Life Processes	74–95
6.	Control and Co-ordination	96–111
7.	How do Organisms Reproduce	112–129
8.	Heredity and Evolution	130–144
9.	Light Reflection and Refraction	145–170
10.	The Human Eye and the colorful world	171–188
11.	Electricity	189–201

12.	Magnetic Effects of Electric Current	202–212
13.	Our Environment	213–224
•	Practice Question Paper	225–240

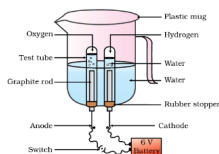

Chapter - 1 Chemical Reactions And Equations

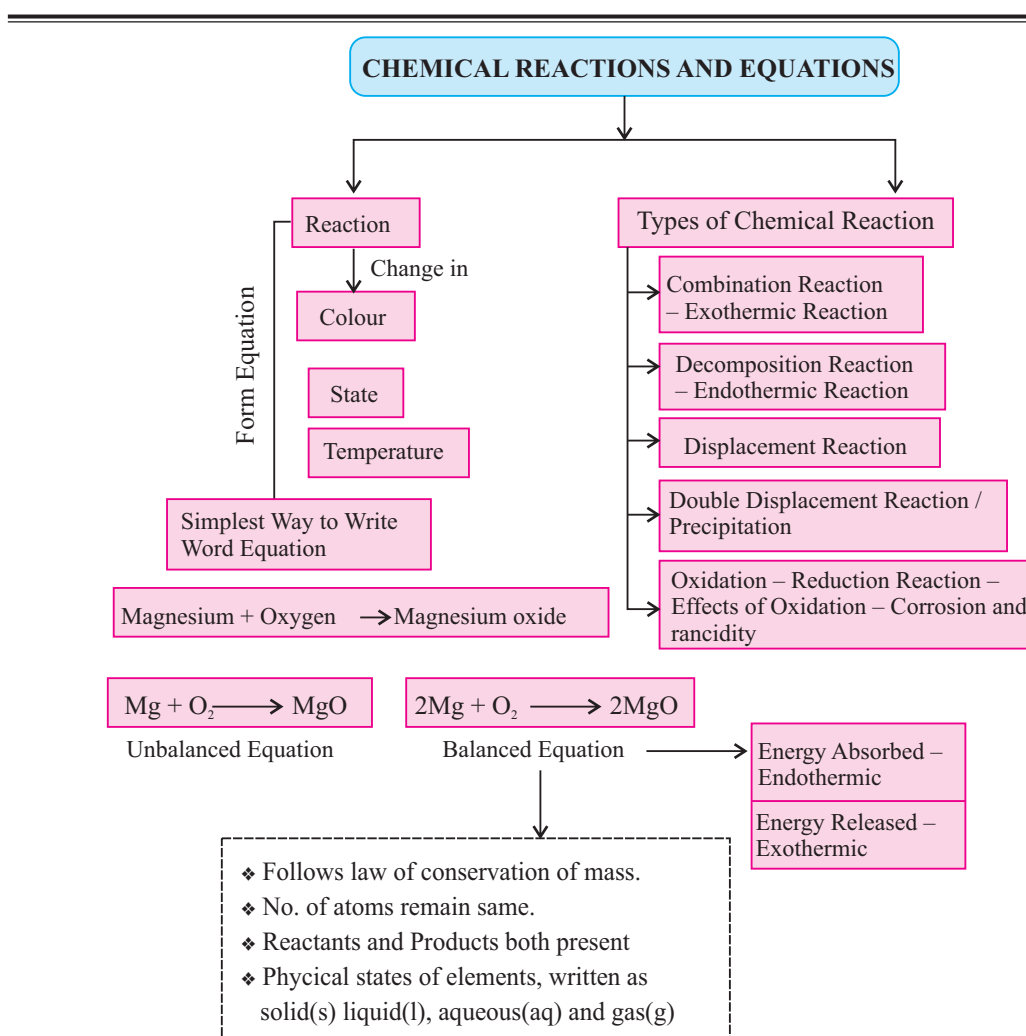

Note: Skeletal equations are usually unbalanced equation but there are few which need not to be balanced as they are already balanced e.g.

Skeleton Equation	Balanced Equation
$C_{(s)} + O_{2(g)} \longrightarrow CO_{2(g)}$	$C_{(s)} + O_{2(g)} \longrightarrow CO_{2(g)}$
$Zn_{(s)} + H_2SO_{4(l)} \longrightarrow ZnSO_4 + H_{2(g)}$	$Zn_{(s)} + H_2SO_{4(l)} \longrightarrow ZnSO_4 + H_{2(g)}$
$S_{(s)} + O_{2(g)} \longrightarrow SO_{2(g)}$	$S_{(s)} + O_{2(g)} \longrightarrow SO_{2(g)}$
$NaCl + AgNO_3 \longrightarrow NaNO_3 + AgCl$ (aq) (aq) (aq) (aq)	$NaCl + AgNO_3 \longrightarrow NaNO_3 + AgCl$ (aq) (aq) (aq) (aq)

The process in which new substances with new properties are formed is called **Chemical Reaction**.

- * The substances which take part in chemical reaction are called **Reactants**.
- * The substances which are formed in a chemical reaction are called **Products**.

Examples :

- (i) Digestion of food
- (ii) Respiration
- (iii) Rusting of iron
- (iv) Burning of Magnesium ribbon
- (v) Formation of curd

Chemical reaction involves :

- Change in state
- Change in colour
- Change in temperature
- Evolution of gas

Ways of Representing a Chemical Reaction

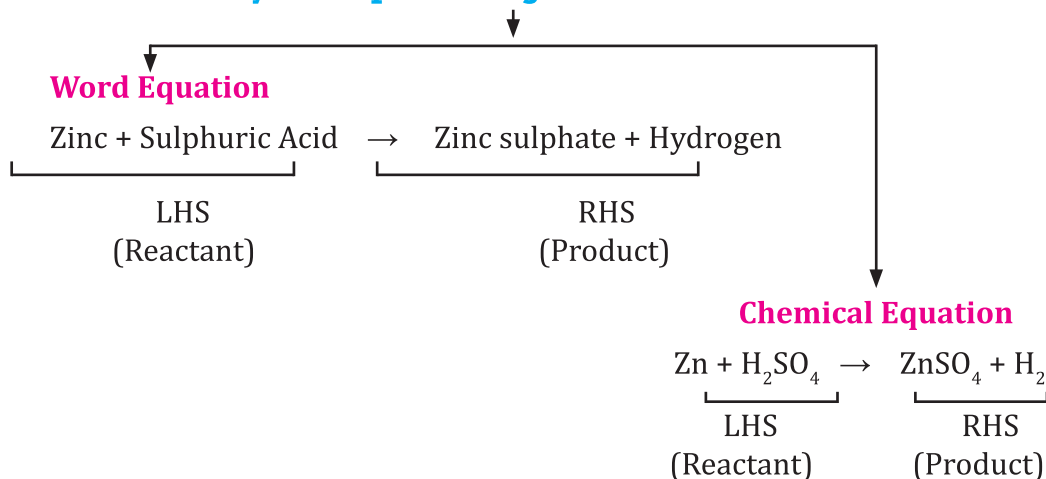

Chemical Equation

- * A chemical reaction can be represented by chemical equation. It involves uses of symbol of elements or chemical formula of reactant and product with mention of physical state.
- * The necessary conditions such as temperature, pressure or any catalyst should be written on arrow between reactant and products.

e.g., Magnesium is burnt in air to form Magnesium oxide.

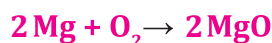

Balancing Chemical Equation

- * Law of conservation of Mass : Matter can neither be created nor be destroyed in a chemical reaction.
- * So number of atoms of the elements involved in chemical reaction should remain same at reactant and product side.

STEPWISE BALANCING (Hit and Trial)

Step 1. Write a chemical equation and draw boxes around each formula.



- * Do not change anything inside the box.

Step 2. Count the number of atoms of each element on both the sides of chemical equation.

Element	No. of atoms at reactant side	No. of atoms at product side
1. Fe	1	3
2. H	2	2
3. O	1	4

Step 3. Equalise the number of atoms of element which has maximum number by putting in front of them.

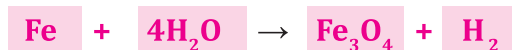

Step 4. Try to equalize all the atoms of elements on reactant and product side by adding coefficient in front of them.

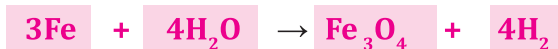

* Now all the atoms of elements are equal on both sides.

Step 5. Write the physical states of reactants and products.

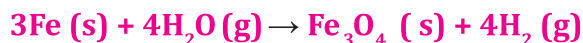

Solid state = (s)

Liquid state = (l)

Gaseous state = (g)

Aqueous state = (aq)

Step 6. Write necessary conditions of temperature, pressure or catalyst on arrow above or below.

TYPES OF CHEMICAL REACTIONS

I. COMBINATION REACTION : The reaction in which two or more reactants combine to form a single product. $A+B \rightarrow C$

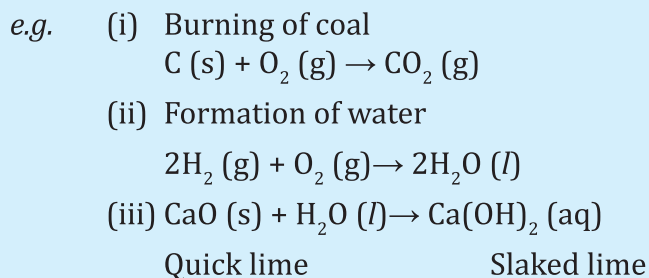

Exothermic Reactions : Reaction in which heat is released along with formation of products.

e.g., (i) Burning of natural gas

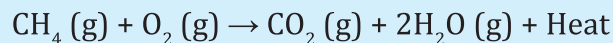

(ii) Respiration is also an exothermic reaction.

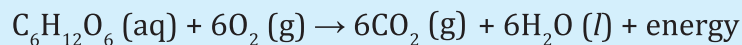

II. DECOMPOSITION REACTION : The reaction in which a compound splits into two or more simple substances is called decomposition reaction.



- **Thermal decomposition :** When decomposition is carried out by heating.

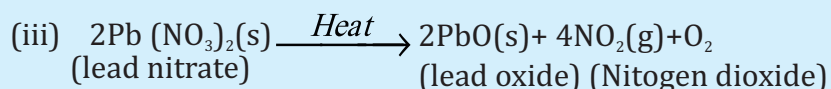
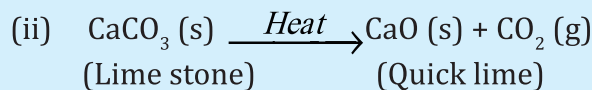
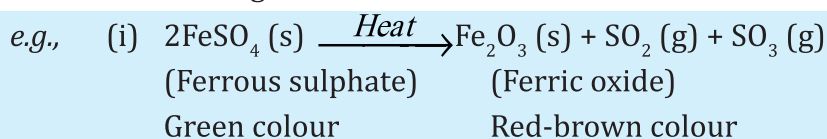

- **Electrolytic Decomposition :** When decomposition is carried out by passing electricity.

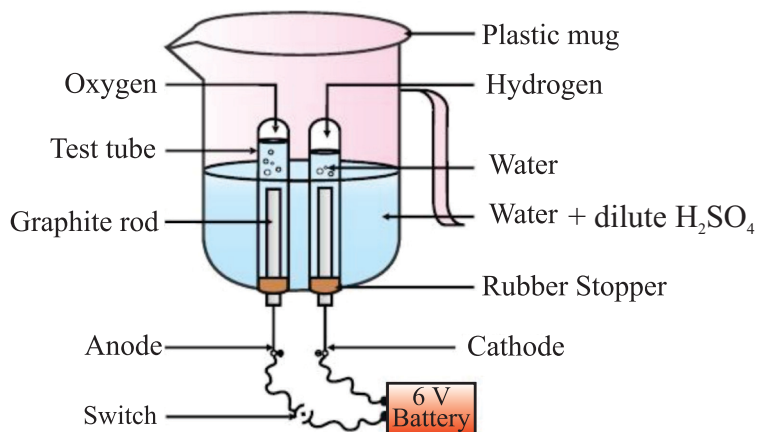
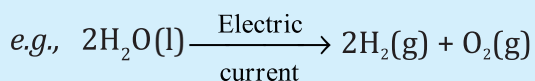

- **Photolytic Decomposition :** When decomposition is carried out in presence of sunlight.

The decomposition reactions are mostly endothermic in nature. Energy in the form of heat, light or electricity is generally absorbed in these reactions.

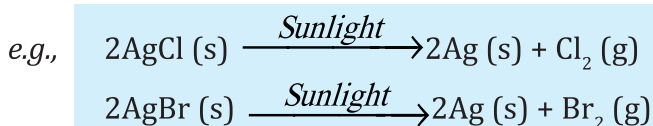

Silver chloride turns grey on exposure to sunlight

- * Above reaction is used in black and white photography.
- **Endothermic Reactions :** The reactions which require energy in the form of heat, light or electricity to break reactants are called endothermic reactions.

III. DISPLACEMENT REACTION : The chemical reaction in which more reactive element displaces less reactive element from its salt solution.

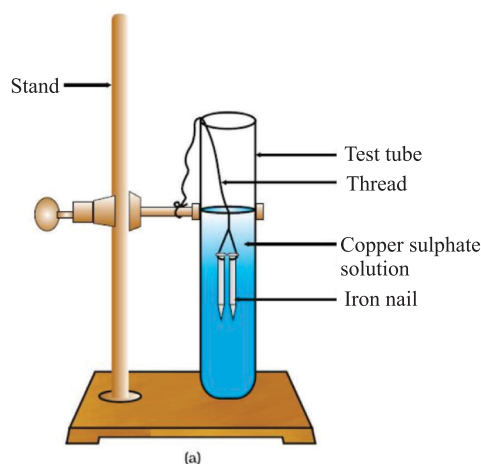

The iron nail becomes brownish in colour by deposition of Cu and blue colour of CuSO_4 changes to dirty green colour due to formation of FeSO_4 .



Zn is more reactive than copper.

IV. DOUBLE DISPLACEMENT REACTION : A reaction in which new compounds are formed by mutual exchange of ions between two compounds.

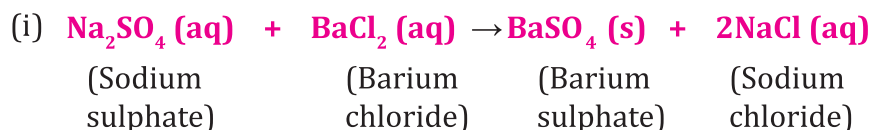

white precipitate of BaSO_4 is formed, so it is also called precipitation reaction.

Note: All double displacement reactions are not precipitation reactions.

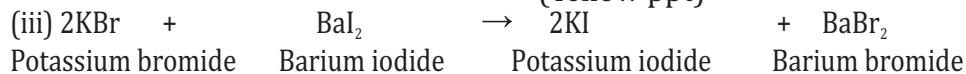
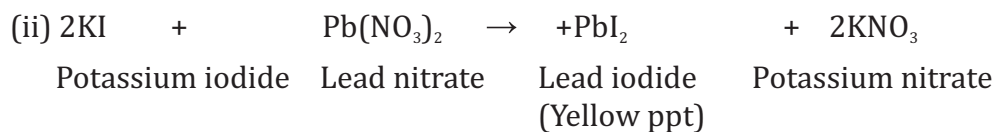

V. OXIDATION AND REDUCTION :

Oxidation : (i) The addition of oxygen to reactant.

(ii) The removal of hydrogen from a reactant.

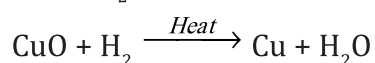
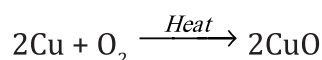
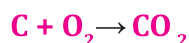

Reduction : (i) The addition of hydrogen to reactant.

(ii) The removal of oxygen from a reactant.

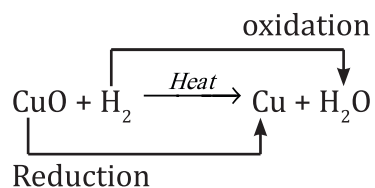

In this reaction CuO is reduced to Cu and H₂ is oxidized to H₂O. So, oxidation and reduction taking place together is redox reaction.

Effects of Oxidation in Daily Life

1) Corrosion

- When a metal is exposed to moisture, air, acid etc. for some time, a layer of hydrated oxide is formed which weakens the metal and hence metal is said to be corroded.
- Rusting of iron, black coating on silver and green coating on copper are examples of corrosion.
- Corrosion can be prevented by galvanization, electroplating or by **applying paints.**

2) Rancidity : The oxidation of fats and oils when exposed to air is known as rancidity. It leads to bad smell and bad taste of food.

Methods to Prevent Rancidity

- (i) By adding antioxidants
- (ii) Keeping food in air tight containers

(iii) Replacing air by nitrogen

(iv) Refrigeration

QUESTIONS

VERY SHORT QUESTIONS (1 Mark)

MULTIPLE CHOICE QUESTIONS

- Q. 1 The shiny finish of wall after white wash is because of.
- a) Calcium oxide b) Calcium hydroxide
c) Calcium Carbonate d) Calcium phosphate
- Q. 2 Electrolysis of water is decomposition reaction. The mole ratio of hydrogen and oxygen gases liberated during electrolysis of water is
- a) 1:1 b) 2:1 c) 4:1 d) 1:2
- Q. 3 Which the following statements about the given reaction are correct:
- $$3\text{Fe(s)} + 4\text{H}_2\text{O(g)} \longrightarrow \text{Fe}_2\text{O}_3\text{(s)} + 4\text{H}_2\text{(g)}$$
- i) Iron metal is getting oxidized
ii) Water is getting reduced
iii) Water is acting as reducing agent
iv) Water is acting as oxidizing agent
- a) (i), (ii) and (iii) b) (iii) and (iv)
c) (i), (ii) and (iv) d) (ii) and (iv)
- Q. 4 In order to prevent the spoilage of potato chips, they are packed in plastic bags containing the gas
- a) Cl_2 b) O_2 c) N_2 d) H_2
- Q. 5 The process of respiration is -
- a) an oxidation reaction which is endothermic
b) a reduction reaction which is exothermic
c) a combination reaction which is endothermic
d) an oxidation reaction which is exothermic

- Q.6 Burning of Methane is an example of
 I. Exothermic reaction
 II. Combustion reaction
 III. Decomposition reaction
 a. I only b. II only c. I and II d. I and III
- Q.7 A solution of substance X is used for white washing, the substance X is
 a. Calcium oxide b. Calcium hydroxide
 c. Calcium carbonate d. Calcium chloride
- Q.8 When iron nails are dipped into Copper Sulphate solution the colour of Copper Sulphate solution changes from
 a. Green to blue b. Blue to green
 c. Green to colourless d. Blue to colourless
- Q.9 The given Chemical reaction is an example of

$$\text{Zn} + \text{CuSO}_4 \longrightarrow \text{ZnSO}_4 + \text{Cu}$$
 a. Combination reaction b. Displacement reaction
 c. Decomposition reaction d. Double displacement reaction
- Q.10 The balanced equation for the given chemical reaction is
 Hydrogen + Chlorine \longrightarrow Hydrogen Chloride
 a. $\text{H}_2 + \text{Cl}_2 \rightarrow 2\text{HCl}$ b. $\text{H} + \text{Cl} \rightarrow \text{HCl}$
 c. $\text{H}_2 + \text{Cl}_2 \longrightarrow \text{HCl}$ d. none of the above
- Q.11 When a magnesium ribbon is burnt in air, the ash formed is
 (a) Black (b) White (c) Yellow (d) Pink.
- Q.12 In reaction $\text{Na}_{(s)} + \text{O}_{2(g)} \rightarrow \text{Na}_2\text{O}_{(s)}$. No. of moles of Sodium needed to balance equation would be
 (a) 1 (b) 2 (c) 3 (d) 4
- (13.) The reaction in which two compounds exchange their ions to form two new compound is called: -
 (a) displacement reaction (b) combination reaction
 (c) Double displacement reaction (d) redox reaction.

Q.14 Which of the given products is formed when calcium oxide reacts with water ?

- (a) Slaked lime (b) Carbon dioxide
(c) calcium oxide (d) Oxygen gas

Q.15 Which of the statement is correct for the following example?

$\text{Fe}_2\text{O}_3 + 2\text{Al} \longrightarrow \text{Al}_2\text{O}_3 + 2\text{Fe}$ is a :-

- (a) combination reaction. (b) double displacement reaction
(C) decomposition reaction. (d) displacement reaction

Answers

1. (b) 2. (b) 3. (c) 4. (a) 5. (d)

Q.16 Give an example of double displacement reaction? (CBSE 2010, 2011)

Q.17 Name the reducing agent in given chemical reaction

$3\text{MnO}_2 + 4\text{Al} \longrightarrow 3\text{Mn} + 2\text{Al}_2\text{O}_3$ (CBSE-2016)

Q.18 Name the brown coloured gas evolved when lead nitrate crystals are heated in dry test-tube.

Q.19 Give reasons-

- a) Silver chloride is stored in dark coloured bottles.
b) Copper vessel loses shine when exposed to air
c) Iron displaces copper from copper sulphate solution.

Q.20 Identify the following reactions as

- i) combination ii) decomposition iii) displacement
iv) double displacement

i) $\text{ZnCO}_3(\text{s}) \longrightarrow \text{ZnO}(\text{s}) + \text{CO}_2(\text{g})$

ii) $\text{Pb}(\text{s}) + \text{CuCl}_2(\text{aq}) \longrightarrow \text{PbCl}_2(\text{aq}) + \text{Cu}(\text{s})$

iii) $\text{H}_2(\text{g}) + \text{Cl}_2(\text{g}) \longrightarrow 2\text{HCl}$

iv) $\text{CaCO}_3(\text{s}) \longrightarrow \text{CaO}(\text{s}) + \text{CO}_2(\text{g})$

v) $\text{NaCl}(\text{aq}) + \text{AgNO}_3(\text{aq}) \longrightarrow \text{AgCl} + \text{NaNO}_3$

vi) $3\text{H}_2(\text{g}) + \text{N}_2(\text{g}) \longrightarrow 2\text{NH}_3(\text{g})$

vii) $\text{Fe}_2\text{O}_3 + \text{Al} \longrightarrow \text{Al}_2\text{O}_3 + 2\text{Fe}$

21. What changes do you observe in iron nails and colour of copper sulphate solution, if iron nails are dipped in CuSO_4 solution for sometime?
22. Identify the chemical change :
Melting of ice or conversion of milk into curd.
23. Why is respiration considered an exothermic reaction ?
24. Why do copper vessel lose shine when exposed to air ?
25. Potato chips manufacturers fill the packet of chips with nitrogen gas. Why ?
26. Why do we store silver chloride in dark coloured bottles in labs?
27. Write a chemical equation of double displacement reaction.
28. $\text{N}_2 + 3\text{H}_2 \rightarrow 2\text{NH}_3$, name the type of reaction.
29. What happens when milk is left open at room temperature during summers ?
30. What happens when quick lime is added to water ?

Practical Based MCQ's

1. When aqueous solution of sodium sulphate and barium chloride are mixed together, we observe-
 - a) precipitate red
 - b) white precipitate
 - c) yellow precipitate
 - d) colourless solution
2. The colour of ferrous sulphate crystals is-
 - a) yellow
 - b) light green
 - c) red
 - d) brown
3. A student took solid quick lime in a china dish and added a small amount of water to it. He would hear-
 - a) pop sound
 - b) a crackling sound
 - c) hissing sound
 - d) no sound at all

4. When an iron nail is placed in copper sulphate solution the observations are as follows-
- a) The solution turns light green
 - b) A brown deposit is formed on the nail
 - c) Both 'a' and 'b'
 - d) None of the above

Answer

1. (b) 2.(b) 3.(c) 4.(c)

Assertion and Reason type of questions

In the following questions a statement of Assertion is followed by a statement of Reason.

Mark the correct choice as two statements are given, one labeled Assertion (A) and the other labeled Reason (R). Select the correct answer to these questions from the codes (a), (b), (c) and (d) as given below:

- (a) Both A and R are true, and R is correct explanation of the assertion.
 - (b) Both A and R true, but R is not the correct explanation of the assertion.
 - (c) A is true, but R is false.
 - (d) A is false, but R is true.
1. **Assertion (R):** Chemical reaction changes the physical and chemical state of substance.
Reason (R): When electric current is passed through water (liquid), it decomposes to produce hydrogen and oxygen gases.
2. **Assertion (R):** In a balanced chemical equation, total mass of each element towards reactant side is equal to the total mass of the same element towards product side.
Reason (R): Mass can neither be created nor destroyed during a chemical change.
3. **Assertion (R):** When calcium carbonate is heated, it decomposes to give calcium oxide and carbon dioxide.
Reason (R): The decomposition reaction takes place on application of heat, therefore it is an endothermic reaction.

4. **Assertion (R):** Chips manufacturers usually flush bags of chips with gas such as nitrogen to prevent the chips from getting oxidised.
Reason (R): This increases the taste of the chips and helps in their digestion.
5. **Assertion (R):** Rusting of iron metal is the most common form of corrosion.
6. **Reason (R):** The effect of rusting of iron can be reversed if they are left open in sun light.

SHORT ANSWER TYPE OF QUESTIONS (2 AND 3 MARKS)

1. Define combination reaction. Give two examples of combination reaction, which are exothermic in nature.
2. What is decomposition reaction ? Explain with the help of an example.
3. Name and state the law which is kept in mind when we balance a chemical equation.
4. Give one example of each :
 - (a) Chemical reaction showing evolution of gas.
 - (b) Change in colour of a substance during a chemical reaction.
 - (c) Chemical reaction showing change in temperature.
5. What is rancidity ? Write two ways by which it can be prevented.
6. What are two conditions which promote corrosion ?
7. A small amount of Ferrous sulphate is heated in hard glass tube.
 - (a) Write the chemical equation.
 - (b) What type of reaction is taking place or Name the type of reaction.
8. What happens when Zn strip is dipped in CuSO_4 solution ?
Give equation and identify the type of reaction.
9. What is redox reaction ? Write down a chemical reaction representing it.

10. In electrolysis of water :
- (a) Name the gas collected at cathode and anode respectively.
 - (b) Why is volume of one gas collected at one electrode is double of another ?
 - (c) Why is it necessary to add few drops of dil. H_2SO_4 to water before electrolysis?
11. In the reaction
- $$\text{CuO (s)} + \text{H}_2 \text{ (g)} \rightarrow \text{Cu(s)} + \text{H}_2\text{O (g)}$$
- (a) Name the oxidized substance.
 - (b) Name the reduced substance.
 - (c) Name the oxidizing agent.
12. Give reasons :
- (a) White Silver chloride turns grey in sunlight.
 - (b) Brown coloured copper powder on heating in air turns into black coloured substance.
13. Compound 'X' decomposes to form compound 'Y' and CO_2 gas. Compound Y is used in manufacturing of cement.
- (a) Name the compounds 'X' and 'Y'.
 - (b) Write the chemical equation for this reaction.
14. A metal salt MX when exposed to light splits up to form metal M and gas X_2 . Metal M is used to make ornaments whereas gas X_2 is used in making bleaching powder. The salt MX is used in black & white photography.
- (a) Identify the metal M and gas X_2 .

- (b) Identify MX.
- (c) Write down the chemical reaction when salt MX is exposed to sunlight.
15. A metal strip X is dipped in blue coloured salt solution YSO_4 . After some time a layer of metal 'Y' is formed on metal strip X. Metal X is used in galvanization whereas metal Y is used for making electric wires.
- (a) What could be metal 'X' and 'Y' ?
- (b) Name the metal salt YSO_4 .
- (c) What type of chemical reaction takes place between X and YSO_4 ?
Write the balanced chemical equation.
- Q.16 When potassium Iodide solution is added to a solution of lead nitrate in test tube, a precipitate is formed.
- i) State the colour of precipitate.
- ii) Name the compound which is precipitated.
- iii) Write balanced equation for chemical reaction (CBSE-2015 Comptt)
- Q.17 Decomposition reactions require energy either in the form of heat or light a electricity for breaking down of reactions. Write one equation for each type of decomposition reaction where heat, light or electricity is used as form of energy. (CBSE-2018)
- Q.18 2 gm of silver chloride is taken in china dish, and china dish is placed in sunlight for sometime. What will be your observation. Write the balanced chemical equation for above reaction and identify the type of reaction. (CBSE-2019)

Q.19 Identify the type of reactions taking place in each of following cases and write the balanced chemical equation for the reactions.

a) Zn reacts with silver nitrate to produce zinc nitrate and silver.

b) Potassium iodide reacts with lead nitrate to produce potassium nitrate and lead iodide (CBSE-2019)

LONG ANSWER TYPE OF QUESTIONS (5 MARKS)

1. White wash was being done at Mukesh's house. Mukesh saw that the painter added quick lime to drum having water. Mukesh touched outer surface of drum, it was unbelievably hot.

(a) Write the chemical equation for above reaction.

(b) What type of reaction is it ?

(c) This reaction is exothermic or endothermic. Justify your answer.

2. Write down the balanced chemical equation for the following :

(a) Silver chloride is decomposed in presence of sunlight to give silver and chlorine gas.

(b) Calcium oxide reacts with water to give lime water.

(c) Sodium hydroxide reacts with hydrochloric acid to give sodium chloride and water.

(d) Dil. hydrochloric acid is added to copper oxide to give green coloured copper chloride and water.

(e) Solution of barium chloride and sodium sulphate in water reacts to give insoluble Barium sulphate and solution of Sodium chloride.

Case Study/Source Based Question

In most pollution control application lime is used as calcium hydroxide. To manufacture calcium hydroxide the limestone must be converted to calcium oxide then calcium oxide then converted to calcium hydroxide. The following is a brief chemical reaction of this process:

Limestone + Heat \longrightarrow Calcium oxide + Carbon dioxide

However, calcium oxide is unstable in the presence of moisture and carbon dioxide. A more stable form of lime is calcium hydroxide.

Calcium oxide + Water \longrightarrow Calcium hydroxide + Heat

The process of adding water to calcium oxide to produce calcium hydroxide is referred to as hydration process or lime slaking. The hydration of Calcium oxide; commercially referred to as quick lime, is an exothermic process releasing a great quantity of heat. The hydration takes place quickly, releasing a lot of heat energy. This heat will boil the water and generate steam, which makes the particles burst, exposing the inner surfaces to water for further slaking. This process will continue until hydration is complete.

(i) Lime is used as calcium hydroxide. The formula of lime is calcium hydroxide that absorbs CO_2 from air and becomes white, the compound formed is

(a) CaO

(b) $\text{Ca}(\text{HCO}_3)_2$

(c) CaCO_3

(d) $\text{CaO} \cdot 2\text{H}_2\text{O}$

(ii) The chemical reaction of the given word equation:

(a) $2\text{CaO} + \text{Heat} \longrightarrow 2\text{Ca} + \text{O}_2$

(b) $\text{CaCO}_3 + \text{Heat} \longrightarrow \text{CaO} + \text{CO}_2$

(c) $\text{Ca}(\text{OH})_2 + \text{Heat} \longrightarrow \text{CaO} + \text{H}_2\text{O}$

(d) $2\text{CaCO}_3 + \text{Heat} \longrightarrow 2\text{CaO} + \text{CO}_2$

(iii) The stable form of lime is

(a) Calcium hydroxide

(b) Calcium oxide

(c) Calcium carbonate

(d) Calcium oxide. Dehydrate

(iv) What is the chemical name and chemical formula of quick lime?

or

What happens when water is added to quick lime? Write its chemical reaction. Is it an exothermic or endothermic reaction?

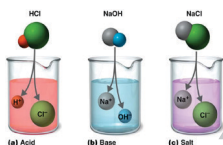
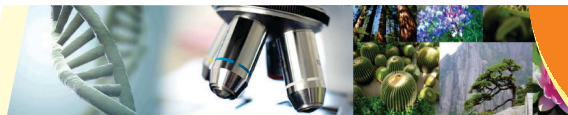

Chapter - 2

Acid, Bases And Salts

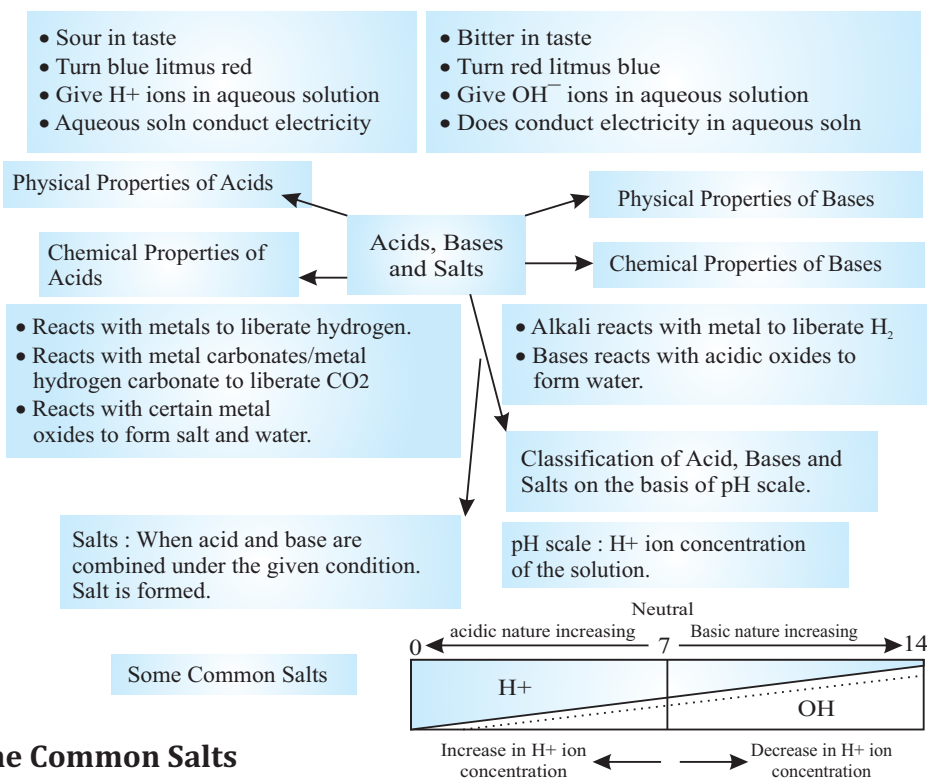

Some Common Salts

- Common salt : NaCl
- Sodium hydroxide : $\text{NaCl} + 2\text{H}_2\text{O} \longrightarrow \text{NaOH} + \text{Cl}_2 + \text{H}_2$
- Bleaching Powder: $\text{Ca}(\text{OH})_2 + \text{Cl}_2 \longrightarrow \text{CaOCl}_2 + \text{H}_2\text{O}$
- Baking Soda: $\text{NaCl} + \text{H}_2\text{O} + \text{CO}_2 + \text{NH}_3 \longrightarrow \text{NH}_4\text{Cl} + \text{NaHCO}_3$
- Wasing Soda: $\text{Na}_2\text{CO}_3 + 10.\text{H}_2\text{O} \longrightarrow \text{Na}_2\text{CO}_3.10\text{H}_2\text{O}$
- Plaster of Paris : $\text{CaSO}_4.2\text{H}_2\text{O} \xrightarrow[\text{heat}]{373 \text{ k}} \text{CaSO}_4. \frac{1}{2} \text{H}_2\text{O} + 1\frac{1}{2} \text{H}_2\text{O}$
- Gypsum : $\text{CaSO}_4. \frac{1}{2}\text{H}_2\text{O} + 1\frac{1}{2}\text{H}_2\text{O} \longrightarrow \text{CaSO}_4. 2\text{H}_2\text{O}$

ACIDS :

- These are the substances which have sour taste.
- They turn blue litmus solution red.
- They give H^+ ions in aqueous solution.
- The term 'acid' has been derived from the Latin word, acidus, which means sour.

Strong Acids : HCl , H_2SO_4 , HNO_3

Weak Acids : CH_3COOH , Oxalic acid, Lactic acid

Concentrated Acid : Having more amount of acid + less amount of water

Dilute Acid : Having more amount of water + less amount of acid

BASES :

- These are the substances which are bitter in taste and soapy in touch.
- They turn red litmus solution blue.
- They give OH^- ions in aqueous solution.

Strong Bases : $NaOH$, KOH , $Ca(OH)_2$

Weak Bases : NH_4OH

Alkalis : These are bases which are soluble in water [$NaOH$, KOH , $Ca(OH)_2$].

SALTS :

These are the compounds formed from reaction of acid and base.

Example :

$NaCl$, KCl .

INDICATORS :

These are the substances which change their colour/smell in different types of substances.

TYPES OF INDICATORS

Natural indicators

- Found in nature in plants.
- Litmus, red cabbage leaves extract, flowers of hydrangea plant, turmeric

Synthetic indicators

- These are chemical substances.
- Methyl orange, phenolphthalein

Olfactory indicators

- These substances have different odour in acid and bases.
- Vanilla, onion, clove

	S. No.	Indicator	Smell/Colour in acidic solution	Smell/Colour in basic solution
Natural Indicator	1.	Litmus	Red	Blue
	2.	Red cabbage leaf extract	Red	Green
	3.	Flower of hydrangea plant	Blue	Pink
	4.	Turmeric	No change	Red
Synthetic Indicator	1.	Phenolphthalein	Colourless	Pink
	2.	Methyl orange	Red	Yellow
Olfactory Indicator	1.	Onion	Characteristic smell	No smell
	2.	Vanilla essence	Retains smell	No smell
	3.	Clove oil	Retains smell	Loses smell

CHEMICAL PROPERTIES OF ACIDS AND BASES

Reaction of Metals with

Acids

Acid + Metal \rightarrow Salt + Hydrogen gas

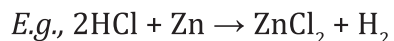

Bases

Base + Metal \rightarrow Salt + Hydrogen gas

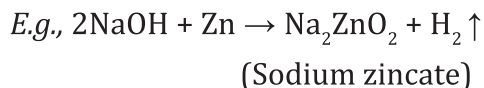

- * Hydrogen gas released can be tested by bringing burning candle near gas bubbles, it burns with pop sound.

Reaction of Metal Carbonates/Metal Hydrogen Carbonates with

Acids

Acid + Metal Carbonate/ Metal Hydrogen Carbonate \rightarrow
Salt + CO_2 + H_2O

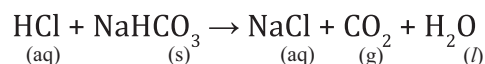
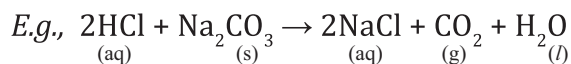

Bases

Base + Metal Carbonate/
Metal Hydrogen Carbonate

\rightarrow No Reaction

- * CO_2 can be tested by passing it through lime water.

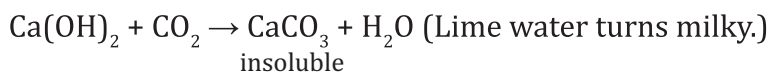

When excess * CO_2 is passed,



Reaction of Acids and Bases With Each Other

Acid + Base \rightarrow Salt + H_2O

Neutralisation Reaction : Reaction of acid with base to give salt and water is called as **neutralisation** reaction.



IF :

Strong Acid + Weak Base \rightarrow Acidic salt + H_2O [pH of the Solution is less than 7]

Weak Acid + Strong Base \rightarrow Basic salt + H_2O [pH of the Solution is more than 7]

Strong Acid + Strong Base \rightarrow Neutral salt + H_2O [pH of the Solution is = 7]

Weak Acid + Weak Base \rightarrow Neutral salt + H_2O [pH of the Solution is = 7]

Reaction of Metallic Oxides with Acids

Metallic oxides + Acid \longrightarrow Salt + Water

Metallic oxides are basic in nature because it reacts with acid and forms salt and water

E.g., CaO, MgO are basic oxides.

Metallic Oxide + Acid \rightarrow Salt + H₂O



Reaction of Non-metallic Oxides with Bases

Non-metallic oxides are acidic in nature.

Non-metallic Oxide + Base \rightarrow Salt + H₂O

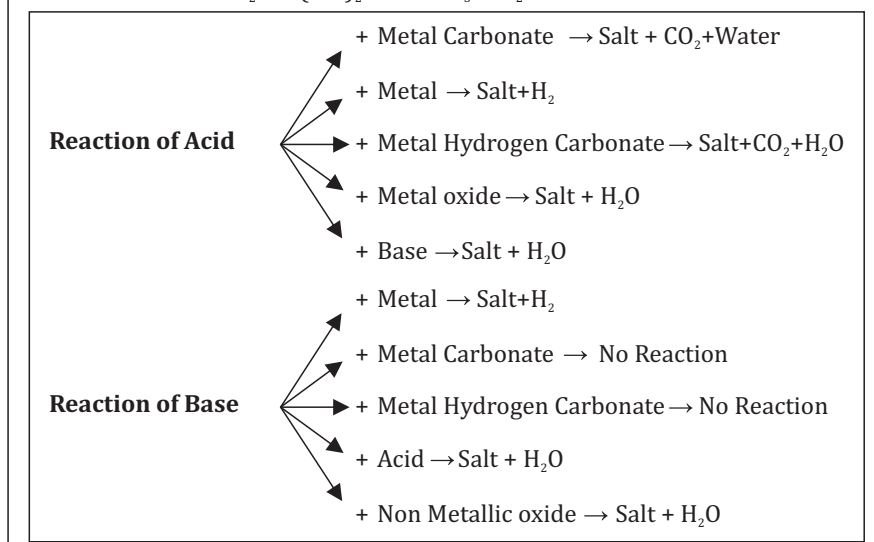
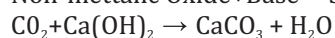

What do all Acids and Bases have in common

- All acids have H⁺ ions in common.
- Acids produce H⁺ ions in solution which are responsible for their acidic properties.
- All bases have OH⁻ (hydroxyl ions) in common.

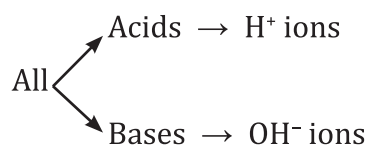

Acid or Base in Water Solution

- Acids produce H^+ ions in presence of water.
- H^+ ions cannot exist alone, they exist as H_3O^+ (hydronium ions).

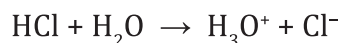
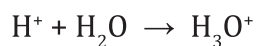

Bases when dissolved in water gives OH^- ions.

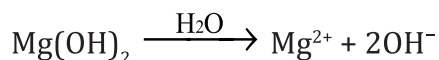
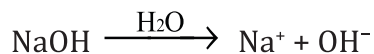

- Bases soluble in water are called alkali.
- While diluting acids, it is recommended that the acid should be added to water and not water to acid because the process of dissolving an acid or a base in water is highly exothermic.



If water is added to acid, the heat generated may cause the mixture to splash out and cause burns and the glass container may also break due to excessive local heating.

Adding water to acid may

Cause mixture to splash out

Break the glass container

Mixing an acid or a base with H_2O results in decrease of concentration of ions (H_3O^+/OH^-) per unit volume. Such a process is called as dilution.

Strength of Acid and Base

Strength of acid or base can be estimated using universal indicator.

Universal indicator : is a mixture of several indicators. It shows different colours at different concentrations of H^+ ions in the solution.

pH Scale : A scale for measuring H^+ ion concentration in a solution . p in pH stands for 'potenz' a German word which means power.

pH = 7 → neutral solution

pH less than 7 → acidic solution

pH more than 7 → basic solution

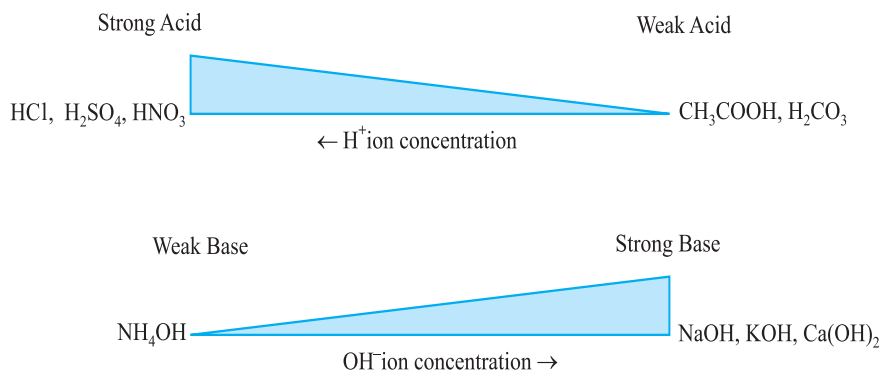

On diluting an acid : pH increases ↑

On diluting a base : pH decreases ↓

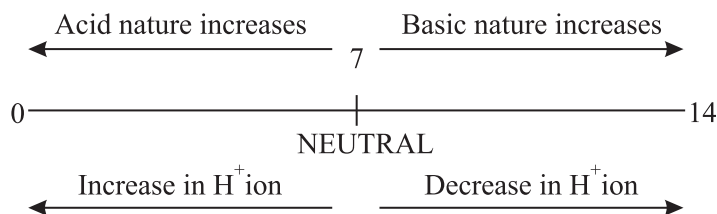

Importance of pH in everyday life

- | | |
|--|--|
| 1. Plants and animals are pH sensitive | <ul style="list-style-type: none"> • Our body works within the pH range of 7-7.8. • When pH of rain water is less than 5.6, it is called acid rain. |
| 2. pH of the soil | <ul style="list-style-type: none"> • Plants require a specific pH range for their healthy growth. If the pH of soil of any place is less or more, then farmers have to mix some acidic or basic substances as required. |

3. pH in our digestive system	<ul style="list-style-type: none"> • Our stomach produces HCl acid which helps in digestion. • During indigestion, stomach produces more acid and cause pain and irritation. • To get rid of this pain, people uses antacid (mild base) like milk of magnesia [$\text{Mg}(\text{OH})_2$] to neutralize excess acid.
4. pH change as cause of tooth decay	<ul style="list-style-type: none"> • Tooth decay starts when pH of mouth is lower than 5.5. • Tooth enamel made up of calcium phosphate (hardest substance in body) does not dissolve in water but corrodes when pH is lower than 5.5 due to acids produced by degradation of food particles by bacteria. • Using toothpaste (generally basic) tooth decay can be prevented.
5. Self defence by animals and plants through chemical warfare	<p>(a) Bee sting leaves an acid which cause pain and irritation. Use of a mild base like baking soda on stung area gives relief.</p> <p>(b) Stinging hair of nettle leaves inject methanoic acid causing burning sensation or pain. Rubbing with leaf of dock plant give relief.</p>

pH of Salts :

- (i) Strong Acid + Strong Base \rightarrow Neutral Salt : pH = 7 eg. NaCl
- (ii) Salt of strong acid + Weak base \rightarrow Acidic salt : pH < 7 eg. NH_4Cl
- (iii) Salt of strong base + Weak acid \rightarrow Basic salt : pH > 7 eg. CH_3COONa

Chemicals from Common Salt (NaCl)

1.	2.	3.	4.	5.
Sodium Hydroxide (NaOH)	Bleaching Powder (CaOCl ₂)	Baking Soda (NaHCO ₃)	Washing Soda (Na ₂ CO ₃ ·10H ₂ O)	Plaster of Paris (CaSO ₄ ·½H ₂ O)

1. Sodium Hydroxide (NaOH) : When electricity is passed through an aqueous solution of NaCl (brine), it decompose to form NaOH. (Chlor-alkali process)

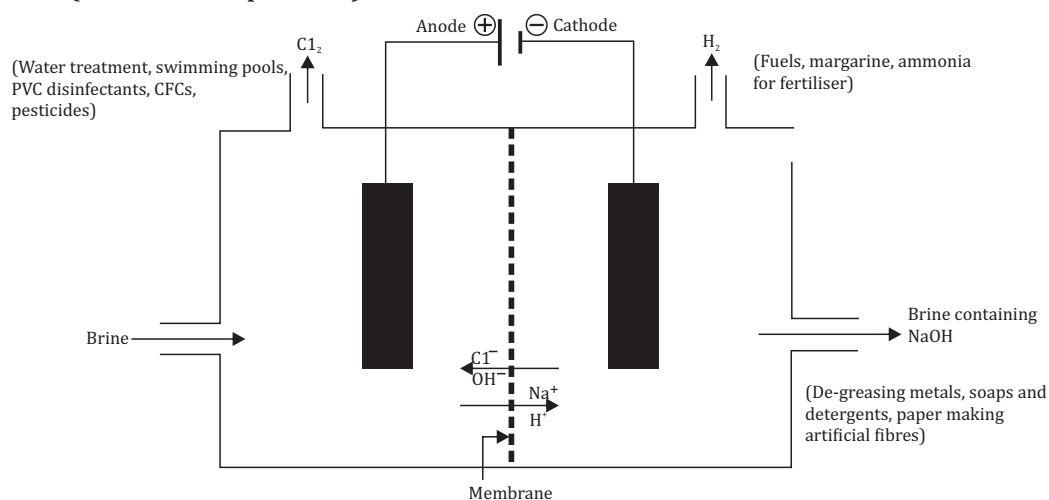

Figure 2.8 Important products from the chlor-alkali process



At anode : Cl₂ gas

At cathode : H₂ gas

Near cathode : NaOH solution is formed.

Uses :

H₂ : Fuels, margarine

Cl₂ : Water treatment, PVC, CFC's

HCl : Cleaning steels, medicines

NaOH : Degreasing metals, soaps and paper making

Cl₂ + NaOH → Bleach : Household bleaches, bleaching fabrics

2. Bleaching Powder (CaOCl_2): It is produced by the action of chlorine on dry slaked lime.



Uses :

- (a) Bleaching cotton and linen in textile industry.
- (b) Bleaching wood pulp in paper factories.
- (c) Oxidizing agent in chemical industries.
- (d) Disinfecting drinking water.

3. Baking Soda (Sodium Hydrogen Carbonate) (NaHCO_3) :



- It is mild non-corrosive base.
- When it is heated during cooking :

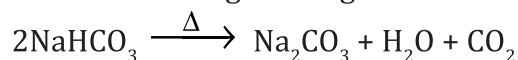

Uses :

- (a) For making baking powder (mixture of baking soda and tartaric acid). When baking powder is heated or mixed with water, CO_2 is produced which causes bread and cake to rise making them soft and spongy.
- (b) An ingredient in antacid.
- (c) Used in soda-acids, fire extinguishers.

4. Washing Soda ($\text{Na}_2\text{CO}_3 \cdot 10\text{H}_2\text{O}$) : Recrystallization of sodium carbonate gives washing soda. It is a basic salt.

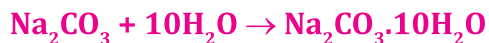

Uses :

- (a) In glass, soap and paper industry.
- (b) Manufacture of borax.
- (c) Cleaning agent for domestic purposes.
- (d) For removing permanent hardness of water.

5. Plaster of Paris (Calcium sulphate hemihydrates) ($\text{CaSO}_4 \cdot \frac{1}{2}\text{H}_2\text{O}$) :

On heating gypsum ($\text{CaSO}_4 \cdot 2\text{H}_2\text{O}$) at 373K, it loses water molecules and becomes Plaster of Paris (POP).

It is a white powder and on mixing with water it changes to gypsum.



Uses :

(a) Doctors use POP for supporting fractured bones.

(b) For making toys, material for decoration.

(c) For making surfaces smooth.

Water of Crystallization : It is a fixed number of water molecules present in one formula unit of a salt.

E.g., $\text{CuSO}_4 \cdot 5\text{H}_2\text{O}$ has 5 water molecules.

$\text{Na}_2\text{CO}_3 \cdot 10\text{H}_2\text{O}$ has 10 water molecules.

$\text{CaSO}_4 \cdot 2\text{H}_2\text{O}$ has 2 water molecules.

VERY SHORT ANSWER TYPE OF QUESTION (1 MARK)

- Q. 1 To protect tooth decay we are advised to brush our teeth regularly. The nature of tooth paste used is-
- a) acidic b) neutral c) basic d) corrosive
- Q. 2 A compound x in aqueous solution turns red litmus solution into blue Identify 'x'
- a) Hydrochloric acid b) Ammonium hydroxide solution.
c) Sodium chloride solution d) Vinegar
- Q. 3 Which one is stronger acid, with pH=5 or with pH=2 ?
- Q. 4 What happens when chlorine is passed over dry slaked lime.
- (CBSE-2010, 2011)
- Q. 5 Dry HCl gas does not change the colour of dry blue litmus paper. Why?
- Q. 6 Fill in the blanks-
- a) The chemical formula of plaster of paris is _____.
- b) Neutral substances have a pH=_____.
- c) Gold can be dissolved in_____.
- d) Commonly used antacid is _____.

Q. 7 Given below are the results of solution tested with universal indicator (pH paper)

- (i) Sulphuric acid Red.
- (ii) Metal Polish Dark Blue.
- (iii) Milk of Magnesia Light blue.
- (iv) Liquid Soap Yellow.
- (v) Over cleaner Purple.
- (vi) Car battery acid Pink.

Arrange the solutions in increasing order of their pH.

Q. 8 Complete the following reaction-

- i) $\text{Na}_2\text{CO}_3 + \text{HCl} \longrightarrow$
- ii) $\text{NaOH} + \text{HCl} \longrightarrow$
- iii) $\text{CuO} + \text{HCl} \longrightarrow$
- iv) $\text{Zn} + \text{NaOH} \longrightarrow$
- v) $\text{Ca}(\text{OH})_2 + \text{Cl}_2 \longrightarrow$

Q.9 Fill the missing data in following table

	Name of salt		Salt obtained	
	Formula		Base	Acid
1	Ammonium chloride	NH_4Cl	NH_4OH	_____
2	Copper sulphate	CuSO_4	_____	H_2SO_4
3	Sodium Chloride	NaCl	NaOH	_____
4	Magnesium Nitrate	$\text{Mg}(\text{NO}_3)_2$	_____	HNO_3
5	Potassium sulphate	K_2SO_4	_____	_____
6	Calcium nitrate	$\text{Ca}(\text{NO}_3)_2$	$\text{Ca}(\text{OH})_2$	_____

Q.10 Classify these chemicals into strong and weak acid-

Hydrochloric acid, Formic acid, nitric acid, acetic acid, Sulphuric acid, citric acid (NCERT Exemplar)

Answer

- 1 c)
- 2 b)

11. Name the acid present in ant sting.
12. What happens when egg shell is added to nitric acid ?
13. Name two constituents of baking powder.
14. What is the pH of gastric juices released during digestion ?
15. Which solution is used to dissolve gold ? Write its constituents.
16. How will you test a gas which is liberated when HCl reacts with an active metal ?
17. Why does flow of acid rain water into a river make the survival of aquatic life in the river difficult ?
18. When conc. acid is added to water, whether the process is exothermic or endothermic ?
19. Which by-product of chlor-alkali process is used for manufacturing bleaching powder ?
20. Name One salt which does not have water of crystallisation.

Practical Based MCQ's

1. On putting a drop of liquid on a pH paper a student observes a small patch of blue color on pH paper. The liquid is most probably-
a) H_2O b) HCl c) NaOH d) H_2SO_4
2. The correct method of finding the pH of solution is—
 - a) Heat the solution in test-tube and expose the pH paper to the vapours formed—
 - b) Pour solution on pH paper
 - c) Dip the pH paper in solution
 - d) Put a drop of solution on pH paper using dropper (CBSE-2011)
3. The colour obtained on pH paper for highly acid, basic and neutral solutions are respectively.
 - a) blue, orange, green
 - b) yellow, blue, green

- c) red, blue, green
 d) red, green, blue
4. Four student- 'A', 'B', 'C' and D measured pH value of water, lemon juice and sodium bicarbonate solution. The student who has expressed correct pH values in decreasing order.
- a) Water > lemon juice > Sod. bicarbonate solution
 b) Lemon juice > Water > Sod. bicarbonate solution
 c) Sod. bicarbonate solution > water > lemon juice
 d) Water > Sod. bicarbonate solution > lemon juice (CBSE-2010)
5. If we add some sodium carbonate in distilled water, the pH of solution will be-
- a) less than 7
 b) more than 7
 c) exactly 7
 d) very close to 7
6. Dil HCl is added to sodium carbonate. It is observed that:-
- a) No change takes place
 b) A loud sound is produced immediately
 c) Immediately a brisk effervescence occur
 d) The solution turns black.
7. A student added Zn granules to dil HCl and made following observations:-
- (i) The surface of Zn become black
 (ii) A colourless gas evolved which burns with pop/sound
 (iii) The solution remains colourless

The correct observations are-

- a) I and II b) I and III c) II and III d) I, II and III
8. Four students performed reactions of zinc and sodium carbonate with dil Hydrochloric acid and sodium hydroxide and presented their result as follows.

The (✓) represent evolution of gas and 'x' represent no reaction.

A		Zn	Na ₂ CO ₃
	HCl	✓	✓
	NaOH	✓	×

B		Zn	Na ₂ CO ₃
	HCl	✓	×
	NaOH	✓	✓

C		Zn	Na ₂ CO ₃
	HCl	×	×
	NaOH	✓	✓

D		Zn	Na ₂ CO ₃
	HCl	✓	✓
	NaOH	×	×

The right set of observation is

a) A b) B c) C d) D

9. A colourless and odourless gas is liberated when hydrochloric acid is added to solution of sodium carbonate. The name of gas is-

- a) Carbon dioxide
- b) Nitrogen dioxide
- c) Sulphur dioxide
- d) Sulphur trioxide

10. When HCl reacts with Zn metal the gas liberated is -

- a) Oxygen b) Nitrogen c) Chlorine d) Hydrogen

Multiple Choice Questions

- An acid can react with
(a) AgCl (b) Na_2CO_3 (c) AgNO_3 (d) None of the above
- Which of the following statement is correct?
(a) Both bases and alkalies are soluble in water
(b) Alkalies are soluble in water but all bases
(c) Bases are soluble in water but all alkalies are
(d) $\text{C}_2\text{H}_5\text{OH}$ is a base because it has OH in its formula
- Solution A,B,C and D have pH 3,4,6 and 8 respectively. The solution with highest acidic strength is
(a) A (b) B (c) C (d) D
- A solution turns blue litmus red. The pH of the solution will be
(a) 8 (b) 10 (c) 12 (d) 6
- Which of the following is a neutral salt
(a) NaCl (b) Na_2SO_4 (c) KCl (d) all of the above
- Which of the following correctly represents the molecular formula of washing soda?
(a) Na_2CO_3 (b) $\text{Na}_2\text{CO}_3\cdot\text{H}_2\text{O}$
(c) $\text{Na}_2\text{CO}_3\cdot 5\text{H}_2\text{O}$ (d) $\text{Na}_2\text{CO}_3\cdot 10\text{H}_2\text{O}$
- Gypsum salt is
(a) $\text{CaSO}_4\cdot 2\text{H}_2\text{O}$ (b) Ca_2SO_4 (c) $\text{CaSO}_4\cdot \frac{1}{2}\text{H}_2\text{O}$ (d) CaSO_4
- Which of the following is used in making toys?
(a) $\text{CaSO}_4\cdot 2\text{H}_2\text{O}$ (b) $\text{Na}_2\text{SO}_4\cdot 10\text{H}_2\text{O}$
(c) $\text{CaSO}_4\cdot \frac{1}{2}\text{H}_2\text{O}$ (d) CaSO_4
- The type of medicine used to treat indigestion is hyperacidity is
(a) antibiotic (b) antacid (c) sulphadiazole (d) pain killer
- Which one of the following is a weak acid
(a) HCl (b) H_2CO_3 (c) HNO_3 (d) H_2SO_4

11. The table provides the PH value of four solutions P, Q R and S.

Solution	PH value
P	2
Q	9
R	5
S	11

Which of the following correctly represents the solution in increasing order of their hydronium ion concentration.

- (a) $P > Q > R > S$
(b) $P > S > Q > R$
(c) $S > Q < R < P$
(d) $S < P < Q < R$
12. Chlorine gas reacts with _____ to form bleaching powder
(a) Dry $\text{Ca}(\text{OH})_2$
(b) Dil. solution of $\text{Ca}(\text{OH})_2$
(c) Con. solution of $\text{Ca}(\text{OH})_2$
(d) Dry CaO
13. A Solution turns red litmus blue, its ph is likely to be
(a) 1 (b) 4
(c) 5 (d) 10
14. Which one of the following salts does not contain water of crystallisation?
(a) Copper sulphate
(b) Baking soda
(c) Washing Soda
(d) Gypsum
15. An aqueous solution turns red litmus solution blue excess addition of which of the following solution would reverse the change?
(a) Baking powder
(b) Lime
(c) Ammonium hydroxide solution
(d) Hydrochloric acid

Assertion and Reason type of questions

In the following questions a statement of Assertion is followed by a statement are given-one labeled Assertion (A) and the other labeled Reason (R). Select the correct answer to these questions from the codes (a), (b), (c) and (d) as given below:

- (a) Both A and R are true, and R is correct explanation of the assertion.
(b) Both A and R are true, but R is not correct explanation of the assertion.
(c) A is true, but R is false.
(d) A is false, but R is true.
- Assertion (A):** Salts are the products of the an acid- base reaction.
Reason (R): Salt may be acidic or basic.
 - Assertion (A):** NaCl is a basic salt.
Reason (R): On passing electricity aqueous solution of NaCl forms NaOH.
 - Assertion (A):** The acid must always be added slowly to water with constant stirring.
Reason (R): The process of dissolving an acid in water is a highly exothermic.
 - Assertion (A):** A scale for measuring hydrogen ion concentration in a solution, called pH scale.
Reason (R): Values less than 7 on the pH scale represent an acidic solution.
 - Assertion (A):** Ammounium chloride is a basic salt.
Reason (R): Salts of strong acid and weak base are acidic with pH value less than 7.

SHORT ANSWER TYPE OF QUESTIONS (2 and 3 Marks)

1. Why does bleaching powder smell strongly of chlorine and does not dissolve completely in water ?
2. Hold one moist and one dry strip of blue litmus paper over dry HCl acid gas. Which strip will turn red and why ?
3. What is Plaster of Paris ? How is it obtained from gypsum ?
4. What is the role of toothpastes in preventing cavities ?
5. Explain why sour substances are effective in cleaning copper vessels ?
6. A white powder is added while baking breads and cakes to make them soft and fluffy. What is the name of the powder ? What are its main ingredients ?
7. How washing soda is prepared from baking soda ?
8. Though the compounds such as glucose and alcohol have hydrogen atoms in their molecule, yet they are not categorized as acids. Why ?
9. What is the reaction called when an acid reacts with base to produce salt and water ? Give example also.
10. Why pickles and curd are not stored in copper and brass utensils ?
11. On passing excess CO_2 through lime water, it first turns milky and then becomes colourless. Explain why ? Write chemical equations.
12. How are bases different from alkalis ? Are all bases alkalis ?
13. While constructing a house, a builder selects marble flooring and marble top for kitchen where vinegar and juices of lemon, tamarind etc. are more often used for cooking. Will you agree to this selection and why ?
14. Indicate with the help of a diagram the variation of pH with change in concentration of H^+ (aq) and OH^- (aq) ions.
15. Write the name and formulae of any three hydrated salts.
16. Give the equation of reaction between calcium carbonate and hydrochloric acid.

17. Why metallic oxides are called basic oxides and non-metallic oxides are called acidic oxides ?
18. What is pH scale ? What is pH value of salt formed by a
- (a) weak acid and strong base ?
 - (b) strong acid and strong base ?
- Q.19 A metal compound 'A' reacts with dil H_2SO_4 to produce a gas which extinguishers a burning candle. Identify compound 'A' and gas produces. Write a balanced chemical equation for the reaction if one of compound formed is sodium sulphate (CBSE-2016)
- Q.20 pH value of salt is 11, which makes Pakoda tasty and crispy. Identify it and write the chemical equation of its formation. Write its two uses also. (CBSE-2018)
- Q.21 A compound which is prepared by gypsum has the property of hardening when mixed with water. Identify and write its chemical formulae. Write the chemical equation for preparation and mention any one use of it? (CBSE sample paper-2018)
- Q.22 Identify the acid and base which form sodium hydrogen carbonate. Write the chemical equation in support of your answer state whether the compound is acidic, basic or neutral. Also write the pH. (CBSE-2019)
- Q.23 A compound 'X' is heated with more con. H_2SO_4 at 443K and produced a Compound 'Y'. Compound 'X' reacts with metal Na and a colourless gas 'z' evolves. Identify 'X', 'Y' and 'Z'. Write the equation of chemical reaction takes place with 'Y' and also write the role of conc H_2SO_4 . (CBSE-2019)
- Q.24 2ml of sodium hydroxide solution is added to few pieces of granulated Zn metal taken in test-tube. When the contents are warmed, a gas is evolved which is bubbled through soap solution before testing. Write the equation of chemical reaction involved and test to detect gas. Name the gas which will be evolved when same metal reacts with solution of strong acid. (CBSE-2018)

Long Answer Type of Questions (5 Marks)

1. What is water of crystallisation? Write the common name and chemical formula of a commercially important compound which has 10 molecules of water. How is this compound obtained? Write its chemical equation also. List any two uses of this compound.
2. An element P does not react with dil H_2SO_4 . It forms an oxide PO which turns red litmus into blue. P is a metal or a non-metal? Justify your answer.
3. What is the chemical name and formula of bleaching powder. What happens when bleaching powder is exposed to air for long time? Give any two important uses of bleaching powder.

Competency Based Questions:

Read the passage carefully and answer the questions:

There are many substances which show one colour or odour in the acidic medium and a different colour or odour in the basic medium. Such substances are called acid-base indicators. An indicator is a weak acid or base that is added to the analyte solution, and it changes colour when the equivalence point is reached. Let's take the real-life example of our fish tank. Over time, plants, rocks, and the fish themselves will alter the pH of the water. Most fish can adjust to a pH that changes slowly over time, but are very sensitive to sudden changes in pH. So when it's time to clean the tank and add new water, we should add water that is near the pH of what the fish have been swimming in and fish do not get a pH shock. To test a solution that whether it is acidic, basic or neutral, we use indicators. There are 3 types of indicators- Natural, Synthetic and Olfactory.

Indicator	Colour in the neutral solution	Colour in the acidic solution	Colour in the basic solution
Litmus	Purple	Red	Blue
Phenolphthalein	Colourless	Colourless	Pink
Methyl Orange	Orange	Red	Yellow

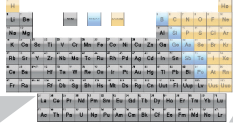

Chapter - 3

Metals And Non-Metals

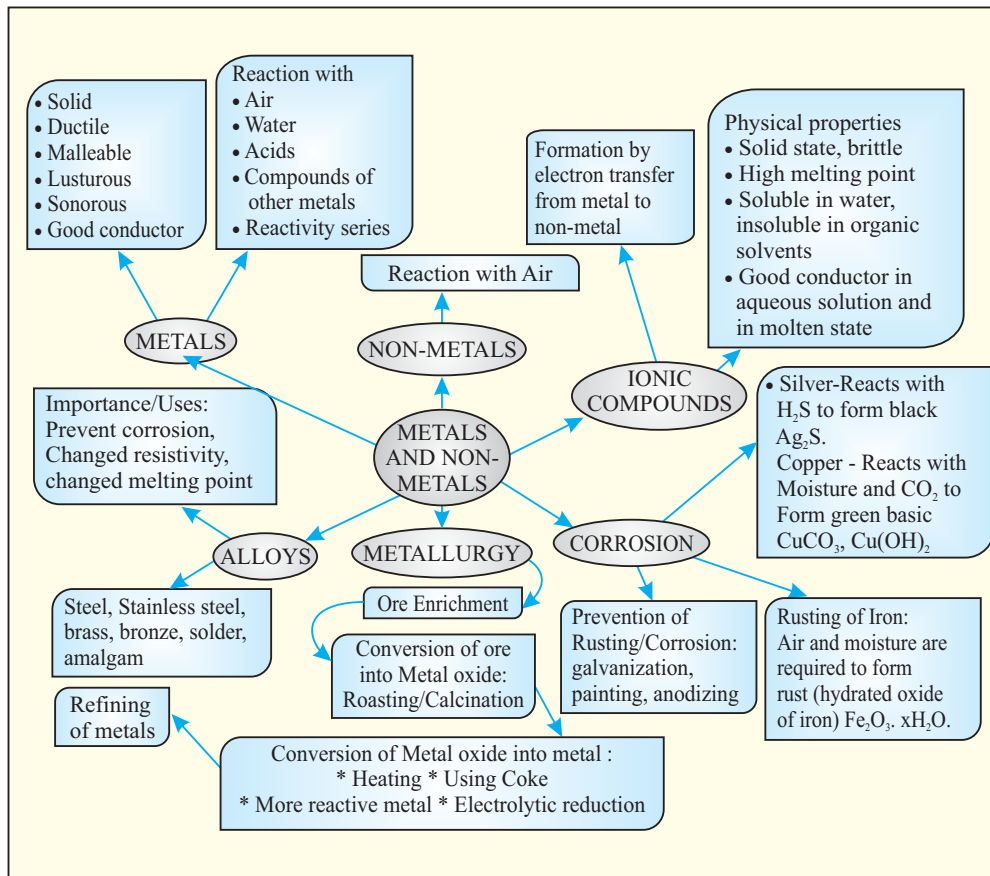

Metals and Non Metals

- About 118 elements are known till date. There are more than 90 metals, 22 non metals and few metalloids.
- Sodium (Na), Potassium (K), Calcium (Ca), Magnesium (Mg), Iron (Fe), Aluminium (Al) are some metals.

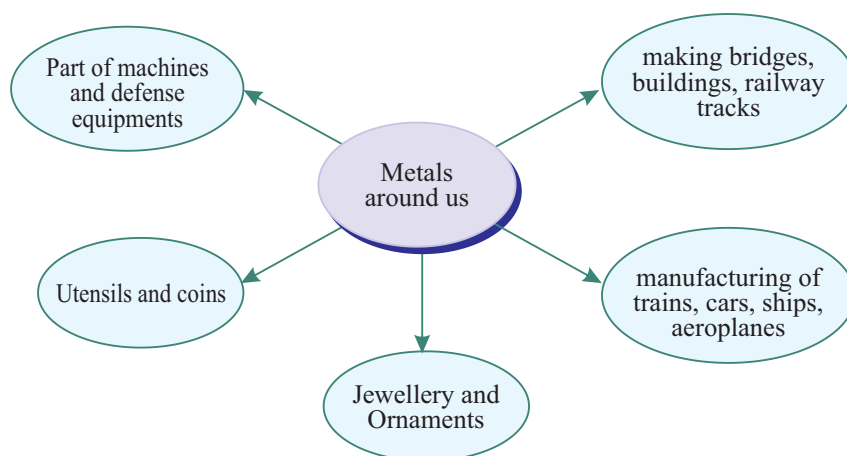

- Oxygen(O), Nitrogen(N), Hydrogen(H), Sulphur(S), Phosphorus(P), Fluorine(F), Bromine(Br) are a few non metals.

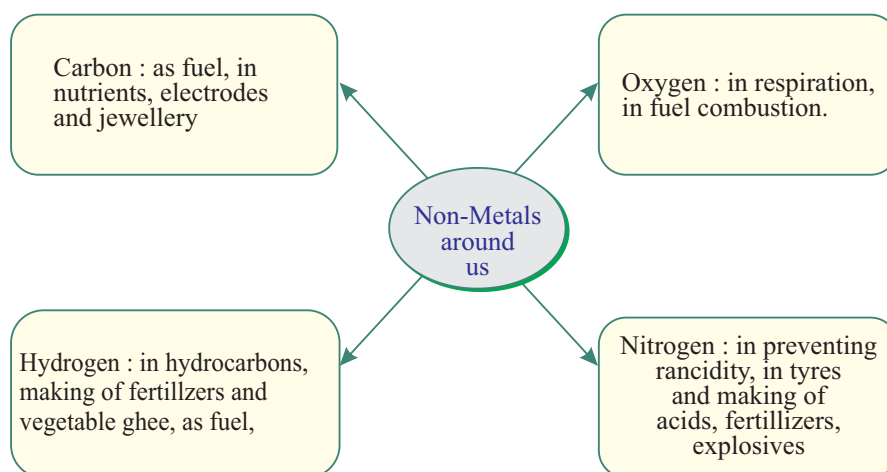

- Differences between metals and non-metals based on

Metals	Non-Metals
<ul style="list-style-type: none"> • Solid at room temperature except mercury 	<ul style="list-style-type: none"> • Exist in all the three states, chlorine-gas, bromine liquid, iodine-solid
<ul style="list-style-type: none"> • Ductile and malleable 	<ul style="list-style-type: none"> • Non-ductile and non-malleable
<ul style="list-style-type: none"> • Sonorous and lustrous 	<ul style="list-style-type: none"> • Non-sonorous and non-lustrous (iodine and graphite are shiny)
<ul style="list-style-type: none"> • Generally have high melting point, cesium and gallium have low melting point. 	<ul style="list-style-type: none"> • Have low melting, except diamond.
<ul style="list-style-type: none"> • Generally good conductors of heat and electricity, except lead and mercury. 	<ul style="list-style-type: none"> • Poor conductors, except graphite.
<ul style="list-style-type: none"> • Have high density, but sodium and potassium have low density. 	<ul style="list-style-type: none"> • Have low density.
<ul style="list-style-type: none"> • Metal oxides can be basic or amphoteric in nature. 	<ul style="list-style-type: none"> • Oxides of non-metals are generally acidic in nature. while a few are neutral oxides
<ul style="list-style-type: none"> • Many metals displace hydrogen from dilute acids and release hydrogen gas. 	<ul style="list-style-type: none"> • Non metals cannot displace hydrogen from dilute acids.
<ul style="list-style-type: none"> • Metal oxides are ionic in nature. 	<ul style="list-style-type: none"> • Non metal oxides are covalent in nature.

Chemical Properties of Metals

1. Reaction with air

Metals can either burn, react or don't react with air



Some metals like Na and K are kept immersed in kerosene as they react vigorously with air. Metals like Mg, Al, Zn and Pb react slowly with air and form a protective layer. Mg can burn in air but combine with oxygen to form oxide. Fe and Cu do not burn in air but combine with oxygen to form their oxides. Iron filings burn when sprinkled in the flame of burner. Silver, platinum and gold show no reaction with air.



- **Amphoteric oxides:** These are metal oxides which react with both acids as well as bases to produce salt and water. e.g. ZnO , Al_2O_3



(Sodium aluminate)

- **Anodizing of metals:** In anodizing, aluminium is made anode and graphite as cathode, oxygen gas is released by the electrolysis of sulphuric acid, which reacts with aluminium to form a thick protective oxide layer on the surface of metal.

2. **Reaction with water:** Metals react with water differently. Not all metals react with water

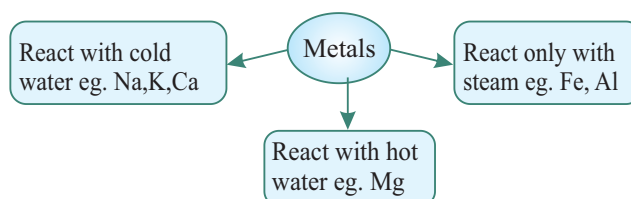

- In case, of Ca and Mg, the metal starts floating due to bubbles of hydrogen gas sticking to its surface.



3. **Reaction with dilute acids:**

- (i) Most metals react with dilute HCl and dilute H_2SO_4 to form salt and hydrogen gas.

Metal + dilute acid \longrightarrow salt + hydrogen gas



- Copper, mercury and silver don't react with dilute acids.

(ii) With dilute nitric acid: As metals react with dilute nitric acid, hydrogen gas produced is oxidised to water. Mg and Mn are exceptions.



Aqua Regia: It is a mixture of concentrated HCl and concentrated HNO_3 in a 3:1 ratio. It dissolves gold and platinum.

4. Reaction with other metal compounds:



More reactive metals can displace less reactive metals from their compounds in solution. This forms the basis of reactivity series of metals.

- **Reactivity series of metals:** It is an arrangement of metals in decreasing order of their reactivity.

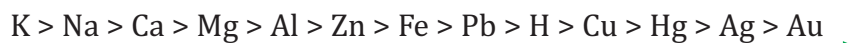

Decreasing reactivity \longrightarrow



Copper being more reactive displace silver.

5. Reaction between metals and non-metals:

- Reactivity of elements can be understood as a tendency to attain a completely filled valence shell arrangement.
- Atom of metals lose valence electron(s) to form cations (+ve ions)
- Atoms of non-metals can gain electron(s) in valence shell to form anions (-ve ions)
- Oppositely charged ions attract each other forming an ionic compound.

Formation of MgCl_2

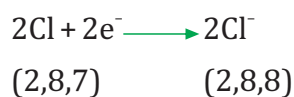

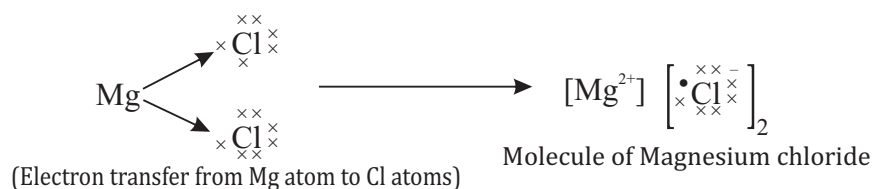

- **Properties of Ionic compounds:** Are solid and mostly brittle.
- Have high melting and boiling points. More energy is required to overcome the strong inter-ionic force of attraction.
- Generally soluble in water, but insoluble in inorganic solvents like kerosene, petrol, etc.
- Conduct electricity in aqueous solutions and in molten state. In both cases, free ions are formed and conduct electricity.

Occurance of Metals

- **Minerals:** Compounds of metals present in earth's crust can be termed as minerals.
- **Ores:** Mineral from which metal can be economically obtained is called an ore e.g. sulphide ores, carbonate ores, oxide ores. Not all the minerals are ores.
- Metals at the bottom of reactivity series like gold, platinum, silver, copper occur in free state. But copper and silver also occur in sulphide and oxide ores.
- Metals of moderate reactivity (Zn, Fe, Pb) occur mainly as oxide, sulphide or carbonate ores. Metals of high reactivity (K, Na, Ca, Mg, Al) are found in combined states.

Gangue: Ores are found mixed with earthly impurities like soil, sand, etc. known as gangue. The gangue is removed from the ore.

Metallurgy: It is the step-wise process of obtaining metal from its ore. These steps are

1. Enrichment of ore.
2. Obtaining metal from enriched ore.
3. Refining of impure metal to obtain pure metal.

Obtaining Metals low in the reactivity series: These metals can be obtained by heating the ore in air at high temperature.

* Mercury from cinnabar:

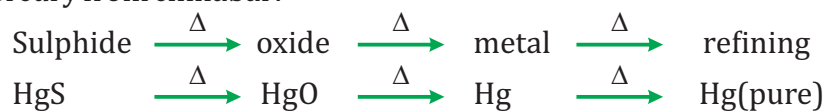

* Copper from copper sulphide

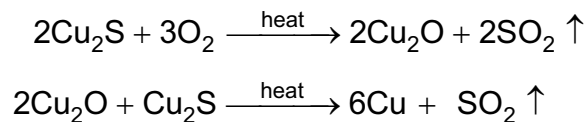

EXTRACTING METALS IN THE MIDDLE OF ACTIVITY SERIES:

Metals are easier to obtain from oxide ores, thus, sulphide and carbonate ores are converted into oxides.

Metal ore heated strongly in excess of air (Roasting)

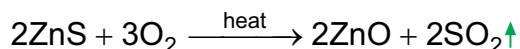

Metal ore heated strongly in limited supply of air (Calcination)

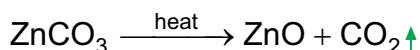

Reduction of metal oxide:

1. **Using coke:** Coke as reducing agent.

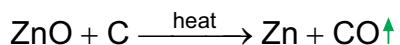

2. **Using Displacement Reaction:** highly reactive metal like Na, Ca and Al are used to displace metals of lower reactivity from their compounds.

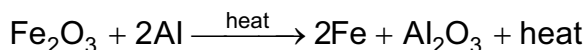
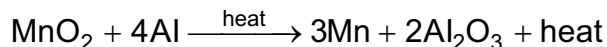

In the above reaction molten iron is formed and is used to join railway tracks. This is called thermit reaction.

EXTRACTING METALS AT THE TOP OF ACTIVITY SERIES:

These metals

* Have more affinity for oxygen than carbon

- * Are obtained by electrolytic reduction. Sodium is obtained by electrolysis of its molten chloride



As electricity is passed through the solution metal gets deposited at cathode and non-metal at anode.

At cathode:



At anode:



REFINING OF METALS:

Impurities present in the obtained metal can be removed by electrolytic refining. Copper is obtained using this method. Following are present inside the electrolytic tank.

- Anode- slab of impure copper
- Cathode- slab of pure copper
- Solution- aqueous solution of copper sulphate with some amount of dilute sulphuric acid.
- From anode copper ions are released in the solution and equivalent amount of copper from solution is deposited at cathode.
- Insoluble impurities containing silver and gold gets deposited at the bottom of anode as anode mud.

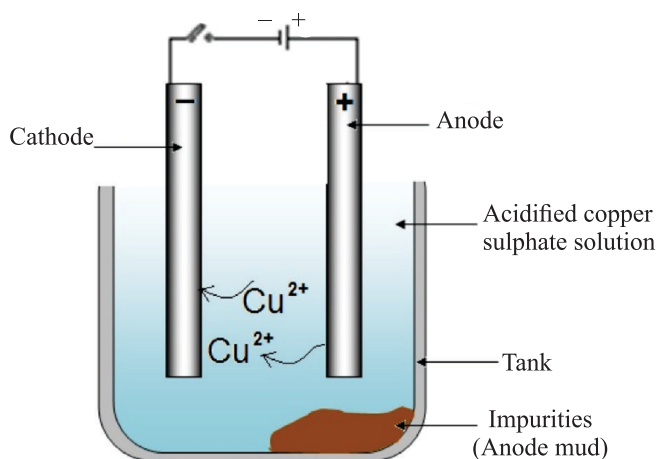

CORROSION:

- Metals are attacked by substances in surroundings like moisture, acids, and moist air.
Silver- it reacts with H_2S in air to form silver sulphide and articles become black.
- Copper- reacts with moist carbon dioxide in air and gains a green coat of basic copper carbonate
- Iron- acquires a coating of a brown flaky substance called rust. Both air and moisture are necessary for rusting of iron.

Prevention of Corrosion:

- Rusting of iron is prevented by painting, oiling, greasing, galvanizing, chrome plating, anodising and making alloys.
- In galvanization iron or steel is coated with a layer of zinc because zinc is preferably oxidized than iron.
- **Alloys:** these are mixture of metals with metals or non-metals Adding small amount of carbon makes iron hard and strong.
- Stainless steel is obtained by mixing iron with nickel and chromium. It is hard and doesn't rust. Mercury is added to other metals to make amalgam. Brass: alloy of copper and zinc (Cu+Zn). Bronze: alloy of copper and tin (Cu+Sn).
- In brass and bronze, melting point and electrical conductivity is lower than that of pure metal.
- Solder: alloy of lead and tin (Pb+Sn) has low melting point and is used for welding electrical wires.

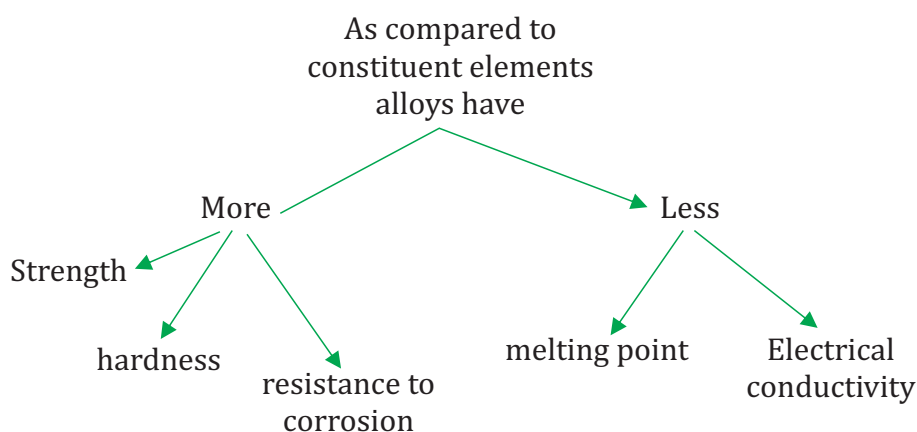

MULTIPLE CHOICE QUESTIONS (1 Mark)

- Which of the following metal is obtained by electrolytic reduction process?
(a) Cu (b) Ag
(c) Fe (d) Al
- Cinnabar is an ore of which metal?
a. Tin b. Aluminium
c. Magnesium d. Mercury
- Which of the following does not conduct electricity?
a. Solid KCl b. Fused KCl
c. Aluminium d. Iron
- Which of the following is not an ionic compound?
(a) Sodium oxide (b) Carbon tetrachloride
(c) Magnesium chloride (d) Sodium chloride
- Which metal is associated with haemoglobin?
(a) Calcium (b) Aluminium
(c) Magnesium (d) Iron
- The liquid non-metal is
(a) Carbon (b) Hydrogen
(c) Bromine (d) Chlorine
- Choose the correct option for brass:
(a) Cu-Hg (b) Cu-Mg
(a) Cu-Fe (d) Cu-Zn
- The colour of Iron(II) sulphate solution is
(a) Blue (b) Yellow
(c) Green (d) Orange
- Electric wires have a coating of insulating material. The material, generally used is -
(a) Graphite (b) Phosphorus
(c) PVC (d) Bromine

10. Ore 'X' of metal 'M' release Carbon dioxide on heating. 'X' can be:
- (a) MNO_3 (b) MCO_3
 (c) MSO_3 (d) MSO_4
11. Which of these melts easily?
- (a) Steel (b) Diamond
 (c) Stainless steel (d) solder
12. $\text{PbO}_{(s)} + \text{C}_{(s)} \xrightarrow{\Delta} \text{Pb}_{(s)} + \text{CO}_{(g)}$
 The role of 'C' in the above reaction is of a
- (a) catalyst (b) Reducing agent
 (c) oxidizing agent (d) solvent
13. Which of the following reaction does not occur?
- (a) Lead metal + silver nitrate solution
 (b) Lead metal + zine sulphate solution
 (c) Magnesium metal + copper sulphate solution
 (d) Copper metal + silver nitrate solution.
14. Copper is used in silver coins to
- (a) reduce melting point (b) increase conductivity.
 (c) reduce solubility (d) increase hardness.
15. Which of the following property is not shown by metals?
- (a) Electrical conduction (b) Sonorous in nature
 (c) Dullness (d) Ductility.

MCQ Correct Options:

1	2	3	4	5	6	7	8
D	D	A	B	D	C	D	C
9	10	11	12	13	14	15	
c	b	d	b	b	d	c	

- Define the following terms: ores, gangue, rust, aqua regia, anodizing.
- Show the reaction between zinc oxide and sodium hydroxide by a chemical equation.

3. Why food cans are coated with tin and not with zinc?
4. Name any two alloys whose electrical conductivity is less than that of pure metals.
5. Why ionic compounds have high melting point?
6. Which element is displaced by metals from acid?

In the following questions , two statements are given- one labeled Assertion (A) and the other labeled Reason (R). Select the correct answer to these questions from the codes (a), (b), (c) and (d) as given below:

- (a) Both A and R are true, and R is correct explanation of the assertion.
- (b) Both A and R are true, but R is not the correct explanation of the assertion.
- (c) A is true, but R is false.
- (d) A is false, but R is true.

1. **Assertion:** Metals have high melting point.

Reason: Metals are found in solid state.

2. **Assertion:** Sulphide ores are roasted.

Reason: It is easier to obtain metal from their oxides.

3. **Assertion:** Anode mud settles at the bottom of electrolytic tank.

Reason: Anode mud contain soluble impurities.

4. **Assertion:** Zinc oxide is an amphoteric oxide.

Reason: It reacts with acid as well as base to produce salt and water.

5. **Assertion:** Silver becomes brown in colour when exposed to air.

Reason: It reacts with hydrogen sulphide and forms silver sulphide .

Read the following passage and answer the questions:

Elements are pure form of matter, which are divided into metals, non-metals and metalloids. Approximately three-quarters of all known chemical elements are metals. The most abundant varieties in the earth's crust are aluminum, iron, calcium, sodium, potassium, and magnesium. The vast majority of metals are found in their ores, but a few such as copper, gold, platinum, and silver frequently occur in the free state because they do not readily react with other elements.

1. Identify the metalloid:

(a) Carbon

(b) Silicon

- Write the differences between electrolytic reduction and electrolytic refining.
- Describe an activity to study conditions necessary for rusting of iron.
- Show the formation of molecules of Magnesium oxide, aluminium oxide and potassium chloride by electron transfer.
- Describe an activity to show the reaction between iron and steam.

5 marks

- (i) Give reasons:
 - Platinum is used to make jewellery.
 - Lithium is stored under kerosene.
 - Aluminium is a highly reactive metal, yet it is used to make utensils for cooking.
 (ii) What is an allotrope? Explain the difference in properties of different allotropes of carbon.
- Give a detailed account of steps of extracting pure copper from its ore.

HINTS to LA Questions

- Unreactive metal, does not get corroded by the action of moisture and atmospheric gases. Highly malleable, ductile
 - Lithium readily reacts with oxygen gas, formed oxide reacts with moisture producing hydrogen gas, which catches fire.
 - Strong and economical metal. Good conductor of heat. On exposure to air it forms aluminium oxide layer all around, which prevents oxidation of the metal inside.
 (ii) Graphite: soft, good conductor of electricity, greyish
 Diamond: hardest natural substance, bad conductor of electricity, transparent.

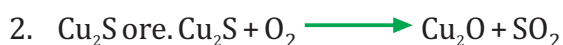

- * pure copper is obtained by electrolytic refining of impure copper.
- * Anode- Impure Copper, Cathode- Pure copper, Electrolytic solution- Aq. Solution of Copper sulphate with few drops of sulphuric acid.
- * Pure metal collects over cathode.

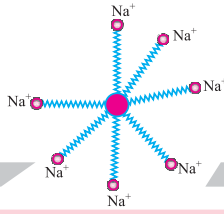

Chapter - 4

Carbon and its Compounds

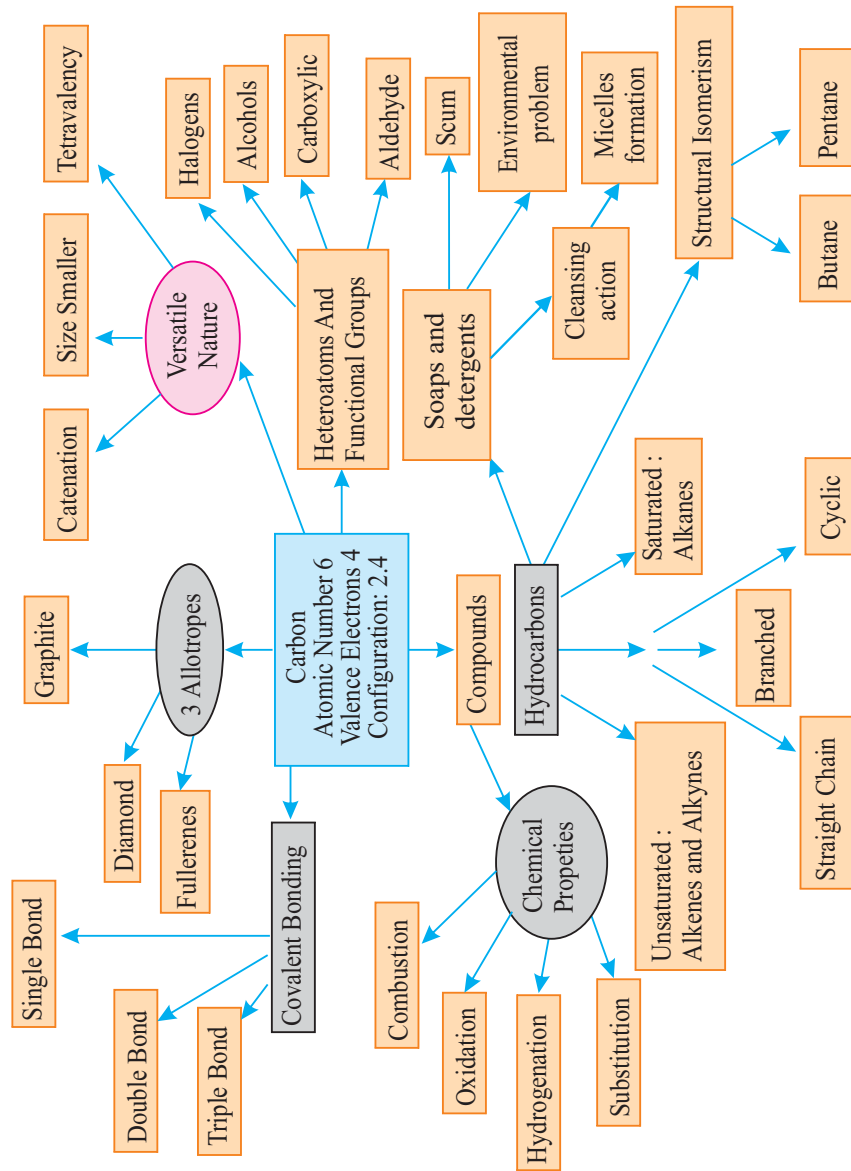

CARBON AND ITS COMPOUNDS

- Carbon is a versatile element.
- In earth's crust, carbon is 0.02% and found in form of minerals.
- Atmosphere has 0.03% of Carbon dioxide.
- All living structures are carbon based.
- Carbon is present in paper, plastic, leather and rubber.

COVALENT BOND IN CARBON

- The atomic number of carbon is 6 and its electronic configuration is 2, 4. To attain a noble gas configuration it can
 1. Gain 4 electrons: But it would be difficult for nucleus to hold 4 extra electrons, and is highly energy requiring process
 2. Lose 4 electrons: But it would require a large amount of energy to remove 4 electrons.
- It is difficult thus for an atom of carbon to either gain or lose electrons.
- Carbon attains the noble gas configuration by sharing its valence electrons, with other atoms. Atoms of other elements like hydrogen, oxygen, nitrogen, chlorine also show sharing of valence electrons.
- Shared electrons belong to the outer shells of both atoms, which thereby achieve noble gas configuration.
- Formation of H_2 , O_2 and N_2 is shown as below:

(i) H_2 molecule

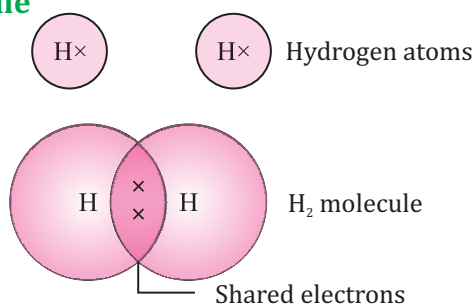

A molecule of hydrogen

A molecule of hydrogen

(ii) O_2 molecule

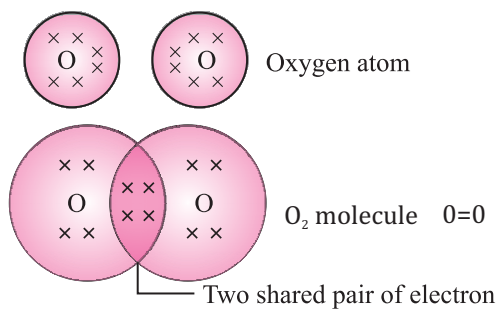

Double bond between two oxygen atoms

(iii) N_2 molecule

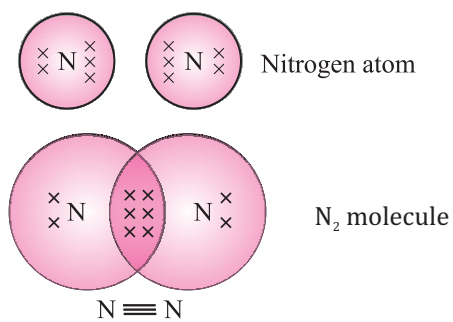

Triple bond between two nitrogen atoms

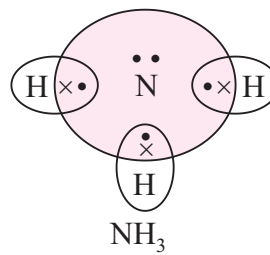
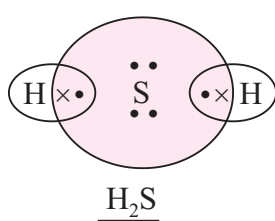
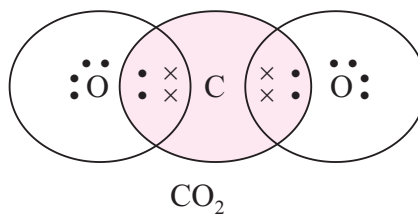
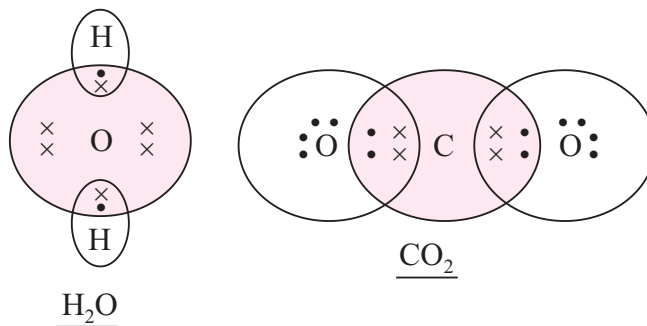

- It is evident that the number of shared pair of electrons can be one, two or three.
- Bond formed by the sharing of an electron pair between two atoms is called covalent bond.
- Covalently bonded molecules have low melting and boiling points because of comparatively weaker intermolecular forces, unlike ionic compounds.
- These molecules are generally poor conductor of electricity since no charged particles are formed.

Allotropes of carbon:

- Diamond:** Each of the carbon atom is bonded to four other atoms of carbon.
- Graphite:** Each of the carbon atom is bonded to three other atoms of carbon. The fourth valence electron can move, thus graphite becomes a good conductor of electricity.
- Fullerenes:** Smallest fullerene has 60 carbon atoms.

Use of (i) Diamond — making jewellery, thermometers.

(ii) Graphite — pencil leads, electrodes, dry lubricant.

These allotropes have same chemical properties.

Difference between diamond and graphite

Diamond	Graphite
<ul style="list-style-type: none"> • It is hardest natural substance • It is an insulator of electricity but good conductor of heat. • It is transparent 	<ul style="list-style-type: none"> • It is soft. • It is good conductor of both heat and electricity • It is opaque

VERSATILE NATURE OF CARBON ATOMS:

Three important properties of carbon atom enable carbon to form enormously large number of compounds.

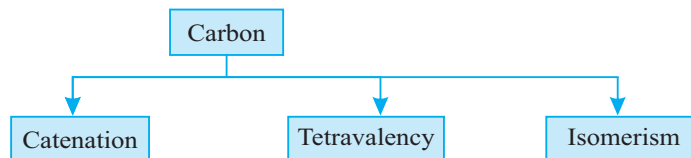

CATENATION: property of carbon atom to form bond with other atoms of carbon is called catenation. Like carbon, silicon forms compounds with hydrogen upto seven or eight atoms of silicon.

TETRAVALENCY: Having a valency of 4, carbon atom is capable of bonding with atoms of oxygen, hydrogen, nitrogen, sulphur, chlorine and other elements.

The smaller size of carbon atom enables nucleus to hold the shared pair of electrons strongly, thus carbon compounds are stable in general.

SATURATED AND UNSATURATED CARBON COMPOUNDS

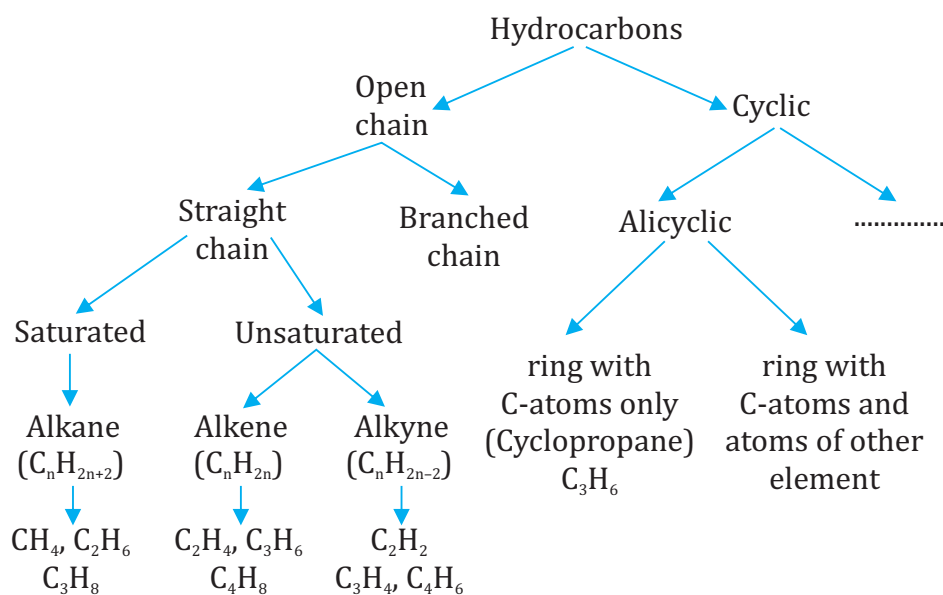

- To have a double/triple bond in chain, at least two carbon atoms are required. So, first member of alkene and alkyne have two-carbon atoms.
- Electron dot structure of a saturated carbon compound, ethane (C₂H₆):

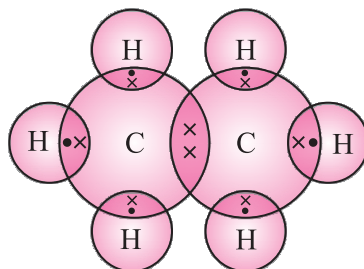

- Electron dot structure of an unsaturated carbon compound, ethene (C_2H_4) and ethyne (C_2H_2)

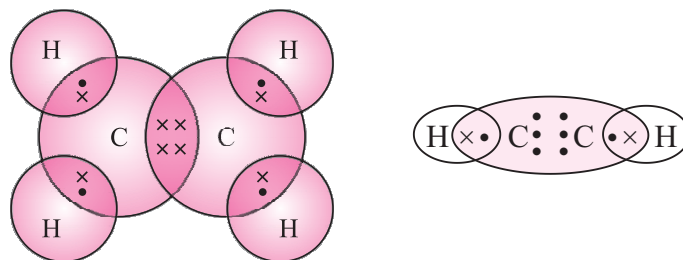

Formulae and structure of compounds of carbon and hydrogen

No. of carbon atoms	Name	Formula	Structure
1	Alkanes: Methane	CH_4	$ \begin{array}{c} H \\ \\ H - C - H \\ \\ H \end{array} $
2	Ethane	C_2H_6	$ \begin{array}{c} H \quad H \\ \quad \\ H - C - C - H \\ \quad \\ H \quad H \end{array} $
3.	Propane	C_3H_8	$ \begin{array}{c} H \quad H \quad H \\ \quad \quad \\ H - C - C - C - H \\ \quad \quad \\ H \quad H \quad H \end{array} $
4.	Butane	C_4H_{10}	$ \begin{array}{c} H \quad H \quad H \quad H \\ \quad \quad \quad \\ H - C - C - C - C - H \\ \quad \quad \quad \\ H \quad H \quad H \quad H \end{array} $

No. of carbon atoms	Name	Formula	Structure
5.	Pentane	C_5H_{12}	$ \begin{array}{ccccccccc} & H & H & H & H & H & & & \\ & & & & & & & & \\ H & - C & - C & - C & - C & - C & - H & & \\ & & & & & & & & \\ & H & H & H & H & H & & & \end{array} $

Name of Hydrocarbon	Molecular formula	Structural Formula
Alkenes :		
1. Ethene	C_2H_4	$ \begin{array}{ccccccc} & H & H & & & & \\ & & & & & & \\ H & - C & = C & - H & & & \end{array} $
2. Propene	C_3H_6	$ \begin{array}{ccccccc} & H & H & & & & \\ & & & & & & \\ H & - C & = C & - C & - H & & \\ & & & & & & \\ & H & & H & & & \end{array} $
3. Butene	C_4H_8	$ \begin{array}{ccccccc} & H & H & & & & \\ & & & & & & \\ H & - C & = C & - C & - C & - H & \\ & & & & & & \\ & H & H & H & H & & \end{array} $
Alkynes :		
1. Ethyne	C_2H_2	$H - C \equiv C - H$
2. Propyne	C_3H_4	$ \begin{array}{ccccccc} & H & & & & & \\ & & & & & & \\ H & - C & \equiv C & - C & - H & & \\ & & & & & & \\ & & & H & & & \end{array} $
3. Butyne	C_4H_6	$ \begin{array}{ccccccc} & H & H & & & & \\ & & & & & & \\ H & - C & \equiv C & - C & - C & - H & \\ & & & & & & \\ & & & H & H & & \end{array} $

Cyclic structures:

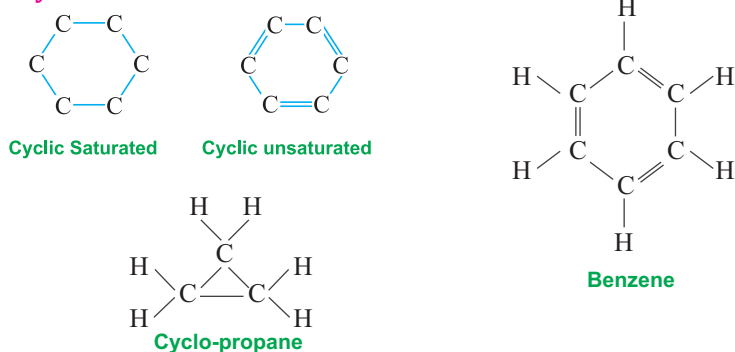

- **Structural isomers:** These are the compounds having identical molecular formula but different structures. Isomers of butane and pentane

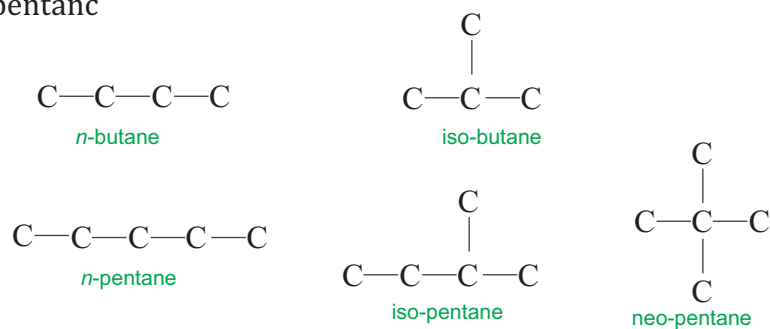

HETEROATOM AND FUNCTIONAL GROUP:

- In hydrocarbon chain, one or more hydrogen atoms can be replaced by other atoms in accordance with their valencies. The element that

Heteroatom	Functional Group	Formula
Cl/Br	Halo (Chloro/Bromo)	— Cl, — Br, — I
Oxygen	1. Alcohol	— OH
	2. Aldehyde	$\begin{array}{l} \text{H} \\ \diagup \\ \text{— C} \\ \diagdown \\ \text{O} \end{array}$ or — CHO
	3. Ketone	$\begin{array}{c} \text{— C —} \\ \\ \text{O} \end{array}$ or —CO—
	4. Carboxylic acid	$\begin{array}{c} \text{— C — OH} \\ \\ \text{O} \end{array}$ or — COOH

replaces hydrogen is called a heteroatom.

- These heteroatoms and the group containing them impart chemical properties to the compound and hence are called functional groups.

HOMOLOGOUS SERIES:

- It is a series of compounds in which the same functional group substitutes for hydrogen in a carbon chain.
- For instance, the alcohols: CH_3OH , $\text{C}_2\text{H}_5\text{OH}$, $\text{C}_3\text{H}_7\text{OH}$, $\text{C}_4\text{H}_9\text{OH}$.
- The successive member differs by $-\text{CH}_2$ unit and 14 units of mass.
- The chemical properties are imparted by the functional group thus all members have similar chemical properties. But the members have different physical properties.
- The physical properties vary among the members of homologous series due to difference in their molecular mass.
- Melting point and boiling point increases with increasing molecular mass.

NOMENCLATURE OF CARBON COMPOUNDS:

1. Identify the number of carbon atoms in the compound.
2. Functional group is indicated either by prefix or suffix.

FUNCTIONAL GROUP	SUFFIX	PREFIX
Alkene	-ene	
Alkyne	-yne	
Alcohol	-ol	
Aldehyde	-al	
Ketone	-one	
Carboxylic acid	-oic acid	
chlorine		chloro-

3. If a suffix is added, then final 'e' is removed from the name. eg. methanol (methane - e = methan + ol).

CHEMICAL PROPERTIES OF CARBON COMPOUNDS

1. COMBUSTION:

- * Carbon compounds generally burn (oxidize) in air to produce carbon dioxide and water, and release heat and light energy.



- * Saturated hydrocarbon burns generally with a blue flame in good supply of air and with a yellow sooty flame in limited supply of air.
- * Sooty flame is seen when unsaturated hydrocarbons are burnt in air.
- * Burning of coal and petroleum emits oxides of sulphur and nitrogen which are responsible for acid rain.

2. OXIDATION:

- * Alcohols can be converted to carboxylic acids by oxidizing them using alkaline potassium permanganate or acidified potassium dichromate (they add oxygen to the reactant, thus are called oxidizing agents)

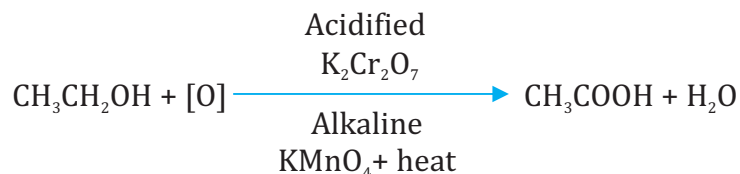

3. ADDITION REACTION:

Hydrogen is added to unsaturated hydrocarbon which are more reactive due to double/triple bond, in presence of nickel platinum or palladium as catalyst. This process is called hydrogenation.

Vegetable oils are converted into vegetable ghee using this process.

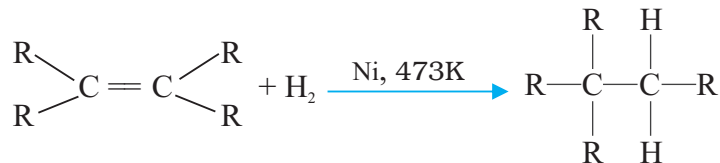

Hydrogenation slows the rancidity of vegetable oils.

Saturated fatty acids are harmful for health and oils with unsaturated fatty acids should be used for cooking.

4. SUBSTITUTION REACTION:

In saturated hydrocarbons, the hydrogen attached to carbon can be replaced by another atom or group of atoms in presence of light or heat.



IMPORTANT CARBON COMPOUNDS: ETHANOL AND ETHANOIC ACID

Ethanol:

Melting Point 156 K	Boiling point 351 K
ETHANOL	
Soluble in Water	Burning taste

* Consumption of dilute ethanol causes serious health issues and intake of pure alcohol is lethal.

Chemical properties of Ethanol

$\text{C}_2\text{H}_5\text{OH}$ Reacts with sodium to form sodium ethoxide and hydrogen

When $\text{C}_2\text{H}_5\text{OH}$ is heated with Concentrated sulphuric acid at 443 K, it is dehydrated to ethene

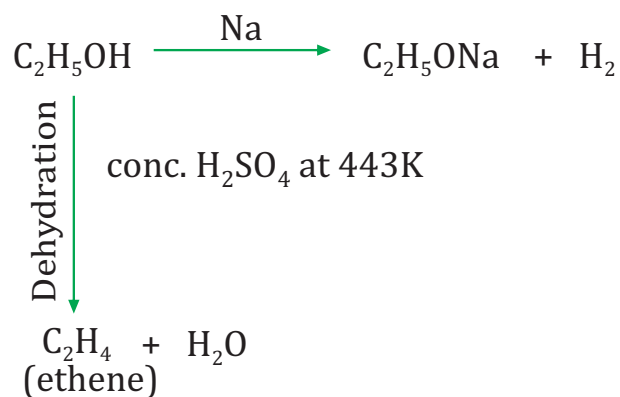

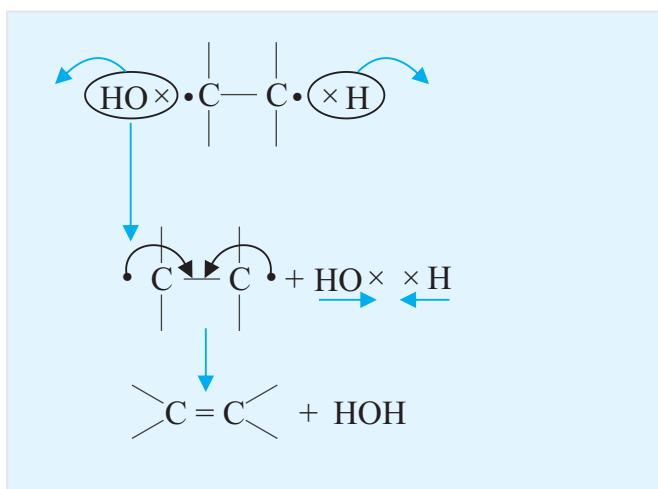

In preparation of transparent soaps, cosmetics	In alcoholic beverages	Antifreeze in radiators of automobiles
Uses of ETHANOL		
As a laboratory reagent	In Medicines and Tonics	

Ethanoic Acid (CH₃COOH)/Acetic Acid

Freezes at 290 K	Boiling point 391 K
Ethanoic Acid	
Miscible in Water	Sour taste

- * Pure acetic acid is called glacial acetic acid.
- 3-4% solution of acetic acid is called vinegar.

Ethanoic Acid:

	React with	Products
1.	Sodium(Na)	• Sodium ethanoate and hydrogen
2.	Sodium Carbonate Na_2CO_3 sodium	• Sodium ethanoate, carbon dioxide and water
3.	Sodium Bicarbonate NaHCO_3 sodium	• Sodium ethanoate, carbon dioxide and water
4.	Ethanol (in presence of conc. sulphuric acid) $\text{CH}_3-\text{CH}_2\text{OH}$	• Ester and water

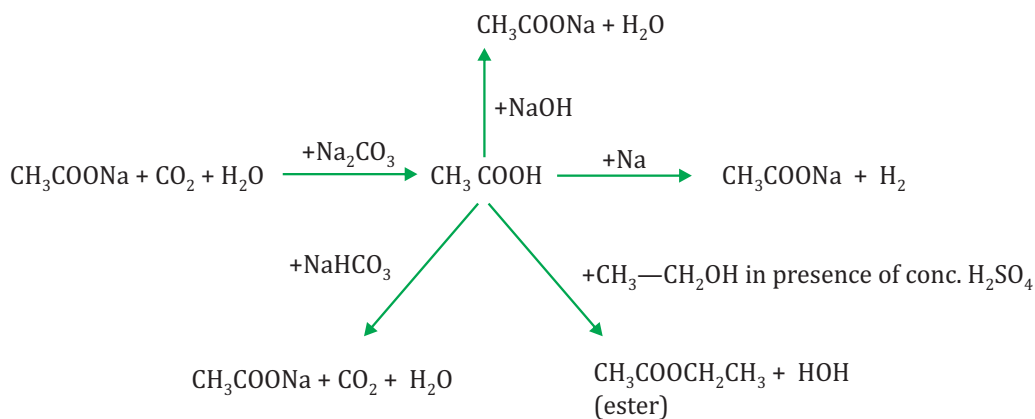

Esterification

Carboxylic acids react with alcohols in presence of few drops of concentrated sulphuric acid as catalyst and form sweet smelling compounds called ester.

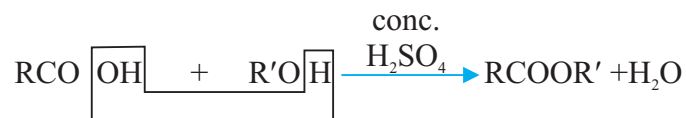

HYDROLYSIS

On heating with an acid or a base, the ester forms back the original alcohol and carboxylic acid.

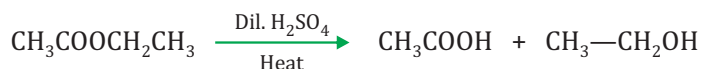

*Alkaline hydrolysis of ester is also called saponification.

SOAPS AND DETERGENTS

- Soap is sodium and potassium salt of carboxylic acids with long chain. ($C_{15}H_{31}COOH$), ($C_{17}H_{35}COOH$) (Palmitic acid, stearic acid)
- Soaps are effective with soft water only and ineffective with hard water.
- Detergents are ammonium or sulphonate salts of hydrocarbons with long chain, they are effective with both soft as well as hard water.
- An ionic part (hydrophilic) and a long hydrocarbon chain (hydrophobic) part constitutes the soap molecule



Cleansing action of Soaps:

- Most dirt is oily in nature and the hydrophobic end attaches itself with dirt, while the ionic end is surrounded with molecules of water. This results in formation of a radial structure called micelles.

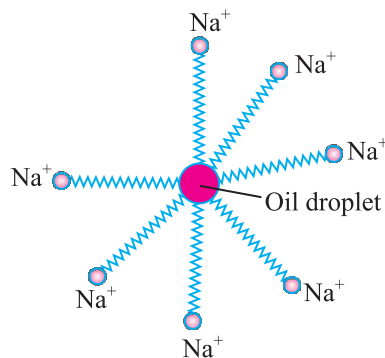

- An emulsion is thus formed by soap molecule. The cloth needs to be mechanically agitated to remove the dirt particles from the cloth.
- Scum: The magnesium and calcium salts present in hard water react with soap molecule to form insoluble products called scum, thus obstructing the cleansing action. Use of detergents overcomes this problem as the detergent molecule prevents the formation of insoluble product and thus clothes get cleaned.

- Soaps are completely biodegradable, while detergents are not. Soaps are environmental friendly but detergents are not.

CARBON AND ITS COMPOUNDS IN BRIEF

- Carbon is a versatile non metal
- Carbon atom, like atoms of other non-metals like oxygen, nitrogen, hydrogen and chlorine shares electrons.
- Carbon forms large number of compounds due to catenation, tetravalency and isomerism.
- Carbon can form single, double and triple covalent bonds
- The compound of hydrogen and carbon are called hydrocarbons which can be saturated or unsaturated.
- Structurally hydrocarbons can have straight chain, branches or cyclic structure.
- Difference in structural arrangement of same molecule gives the isomers.
- In a hydrocarbon, a hetero atom can replace the hydrogen atom and impacts its chemical properties. Homologous series is a series of compounds with same general formula and same chemical properties but different physical properties.
- Carbon based compounds are excellent fuels.
- Ethanol is an important industrial compound. It reacts with reactive metals and is also dehydrated to ethene.
- Ethanoic acid is another important compound. It combines with ethanol to form sweet smelling esters.
- Soaps and detergents are used as cleansing agents. Detergents efficiently cleanse with soft and hard water.

MULTIPLE CHOICE QUESTIONS

1. Which of the following metal is used as a catalyst in hydrogenation?
 - a. Cu
 - b. Ni
 - c. Fe
 - d. Na

COMPETENCY BASED QUESTIONS:

Consumption of alcohol in large quantities slows down the metabolic processes and affects the central nervous system. It results in difficulties such as lack of coordination, mental confusions, drowsiness, lowering of normal inhibitions and finally stupor. Along with these harmful effects, ethanol is an important industrial solvent, it is used in different industries with water and with many organic solvents, including acetic acid, acetone, benzene, carbon tetrachloride. It is used as fuel in jet engines in countries like Brazil.

1. Identify the heteroatom in ethanol.
 - a. Carbon
 - b. Hydrogen
 - c. Bromine
 - d. Oxygen
2. Which acid is constituent of vinegar?
 - a. Ethanoic acid
 - b. Carbonic acid
 - c. Oxalic acid
 - d. Lactic acid
3. Complete the following chemical equation.
$$\text{C}_2\text{H}_5\text{OH} + \text{CH}_3\text{COOH} \xrightarrow{\text{conc. H}_2\text{SO}_4} \text{_____} + \text{_____}$$
4. Draw the structure of ethanol molecule.
5. Describe the harmful effects of consuming alcohol?

VSA 1 MARK

1. How does an atom of carbon attain noble gas configuration?
2. Draw the electron dot structure of molecule of CCl_4
3. Define catenation.
4. The kerosene/gas stoves have inlets for air. Give reason.
5. Write only the balanced chemical equation for dehydration of ethanol by hot concentrated sulphuric acid.
6. Draw the structure for propyne.
7. Write the formula of first member of ketone.
8. What is an oxidising agent? Give example.
9. Which energy is used to convert methane into chloromethane?
10. Write a balanced chemical equation for burning of ethanol in oxygen.

In the following questions, two statements are given- one labeled Assertion (A) and the other labelled Reason (R). Select the correct answer to these questions from the codes (a), (b), (c) and (d) as given below:

- (a) Both A and R are true, and R is correct explanation of the assertion.
 - (b) Both A and R are true, but R is not the correct explanation of the assertion.
 - (c) A is true, but R is false.
 - (d) A is false, but R is true.
1. ASSERTION: Butane is less reactive than butene.
REASON: Presence of double bond increases the reactivity of molecule.
 2. ASSERTION: Unsaturated hydrocarbons burn in air with blue flame.
Reason: Incomplete combustion of hydrocarbons causes a yellow flame.
 3. ASSERTION: Detergents are not environment-friendly.
Reason: Detergents are not easily bio-degradable.
 4. ASSERTION: Alkanes show addition reaction.
Reason: Addition reaction is a characteristic property of unsaturated hydrocarbons.
 5. ASSERTION: Pentane has three isomers.
Reason: For structural isomerism hydrocarbons should have 4 or more carbon atoms.

2 Marks

1. Define saponification. Write a chemical equation for it.
2. Covalent compounds generally don't conduct electricity. Why?
3. Specify the condition due to which ethanol undergo oxidation to form ethanoic acid. Write the chemical equation.
4. Define structural isomerism. Draw the structures of two isomers of butane.
5. Identify the functional group in the following compounds, methanoic acid, methanal, bromo ethane and hexanol.
6. Why is ethanoic acid called as glacial acetic acid. Write the chemical equation for esterification.

7. Draw the structure of benzene.
8. Why are carboxylic acids known as weak acids? Name the alcohol which produces methanoic acid on oxidation.
9. A mixture of oxygen and ethyne is burnt for welding. Can you tell why a mixture of air and ethyne is not used?
10. (i) Which property of ethanol makes it suitable for making cough syrups and tincture iodine?
(ii) What is the function of concentrated sulphuric acid in the formation of ethene from ethanol?

3 Marks

1. What is a homologous series? List any of its four features.
2. State any three characteristics of structural isomers of any compound.
3. Propanal and propanone are structural isomers. Explain.
4. Explain why carbon atom is unable to form either cation or anion?
5. Describe substitution reaction with the help of an example.
6. Give a test that can be used to differentiate between saturated and unsaturated hydrocarbons.
7. Explain the formation of scum when hard water is treated with soap.
8. Distinguish between soap and detergent.
9. Describe the two properties of carbon which lead to the formation of huge number of compounds.

5 Marks

1. Explain the mechanism of the cleaning action of soaps with the help of diagram.
2. A neutral organic compound X of molecular formula C_2H_6O on oxidation with alkaline $KMnO_4$ gives compound Y. Compound X and Y react on warming in presence of concentrated sulphuric acid to produce a sweet smelling substance Z. Identify X, Y and Z. Also write the corresponding chemical equations.

HINT

1. Soap molecule structure, application on wet dirty cloth, micelles formation process, mechanical agitation, suitable diagrams
2. X- ethanol, Y- ethanoic acid, Z- ester ethyl ethanoate, chemical equations.

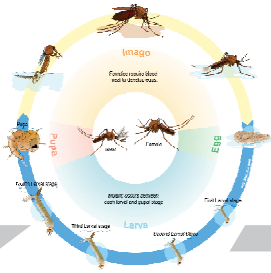

Chapter - 5

Life Processes

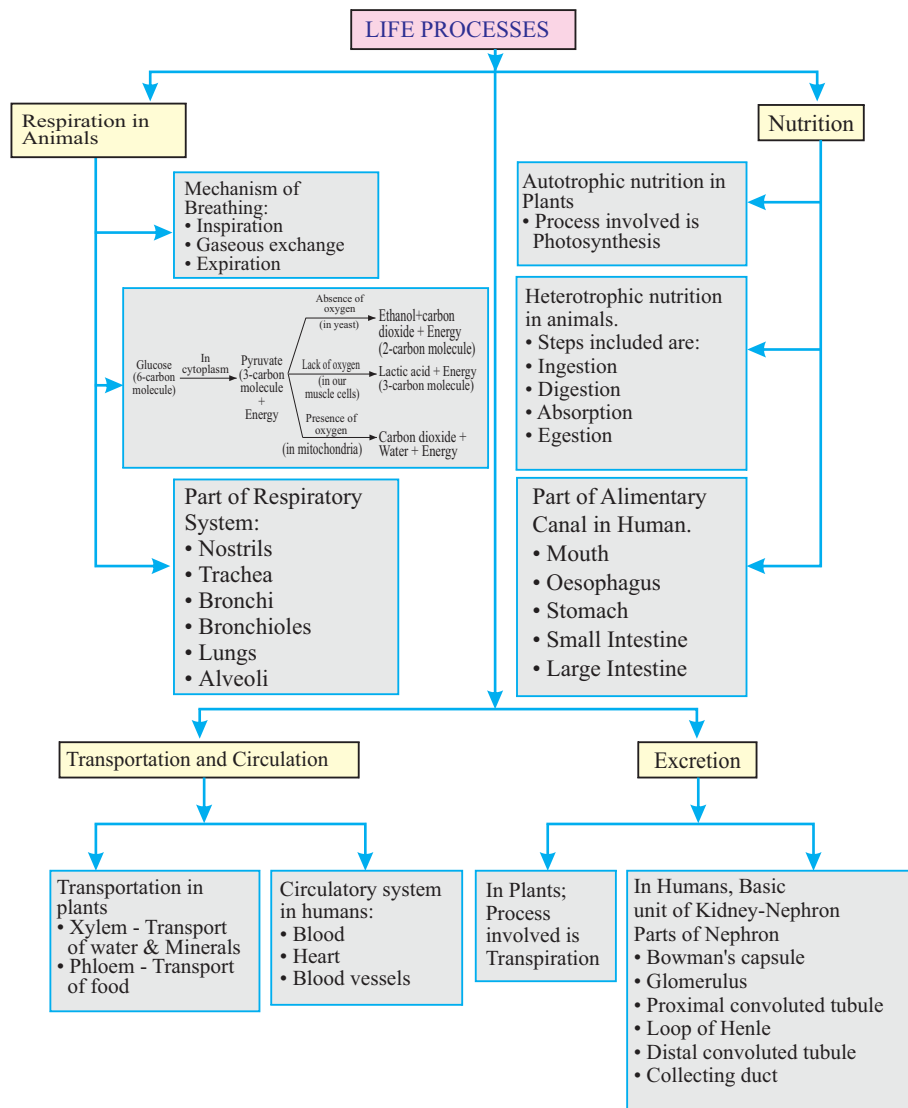

All living things perform certain life processes like growth, excretion, respiration, circulation etc.

All the processes like respiration, digestion, which together keep the living organisms alive and perform the job of body maintenance are called life processes.

Examples :

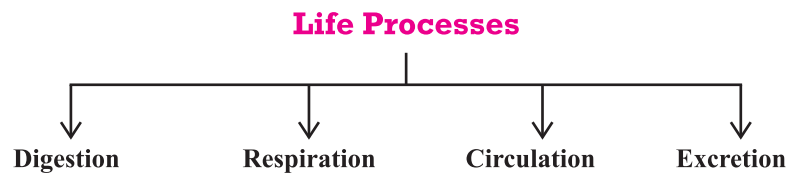

I. Nutrition

(The whole process by which an organism obtains its food)

Nutrition in Plants



Plants are autotrophs.



Can make their own food.

Nutrition in Animals



Animals are heterotrophs.



Depend on plants or other animals for their food

Modes of Nutrition

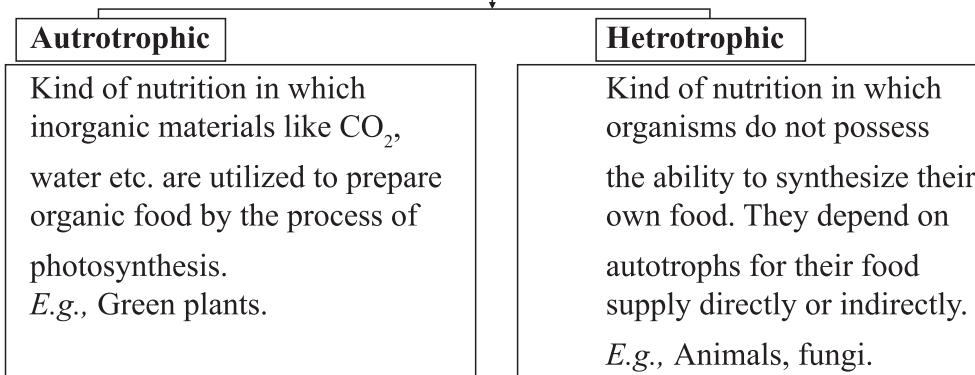

Autotrophic Nutrition :

The organisms which carry out autotrophic nutrition are called autotrophs (green plants).

Autotrophs $\xrightarrow{\text{Use}}$ Simple inorganic material $\xrightarrow[\text{in to}]{\text{Convert}}$ Complex high energy molecules (Carbohydrates)

Autotrophic nutrition is the process by which autotrophs take in CO₂ and H₂O and convert these into carbohydrates in the presence of chlorophyll, sunlight is called **Photosynthesis**.

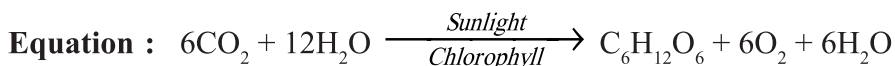

Raw Material for Photosynthesis :

- Sunlight
- Chlorophyll → Sunlight absorbed by chlorophyll
- CO₂ → Enters through stomata and oxygen (O₂) is released as by-product through stomata on leaf.
- Water → Water + dissolved minerals like nitrogen, phosphorus etc. are taken up by the roots of the soil.

Site of Photosynthesis :

Chloroplast in the leaf, chloroplast contain chlorophyll (green pigment).

Main Events of Photosynthesis :

- Absorption of light energy by chlorophyll

- Conversion of light energy into chemical energy + splitting (breaking) of water into hydrogen and oxygen
- Reduction of CO_2 to carbohydrates

Stomata : Tiny pores present on the surface of the leaves.

Functions :

- Exchange of gases O_2/CO_2 .
- Loses large amount of water (water vapour) during transpiration.

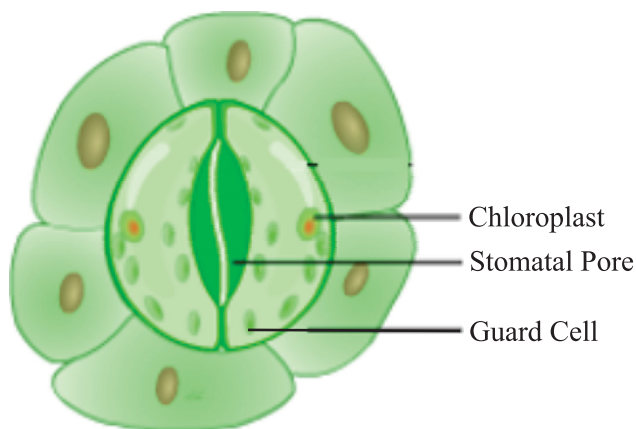

Heterotrophic Nutrition

Holozoic	Saprophytic	Parasitic
Animals take in solid food and <u>break it down</u> inside the body. <i>E.g., Amoeba, animals.</i>	Organisms feed on dead, decaying matter. <i>E.g., Fungi.</i>	Parasites live inside or outside other organism (host) and derive nutrition from it. <i>E.g., Cuscuta (plant parasites), Ticks leech etc</i>

How do organisms obtain their food

Unicellular/Single celled organisms : Food is taken up through entire surface.

- Example : (i) Amoeba
(ii) Paramecium

(i) Amoeba

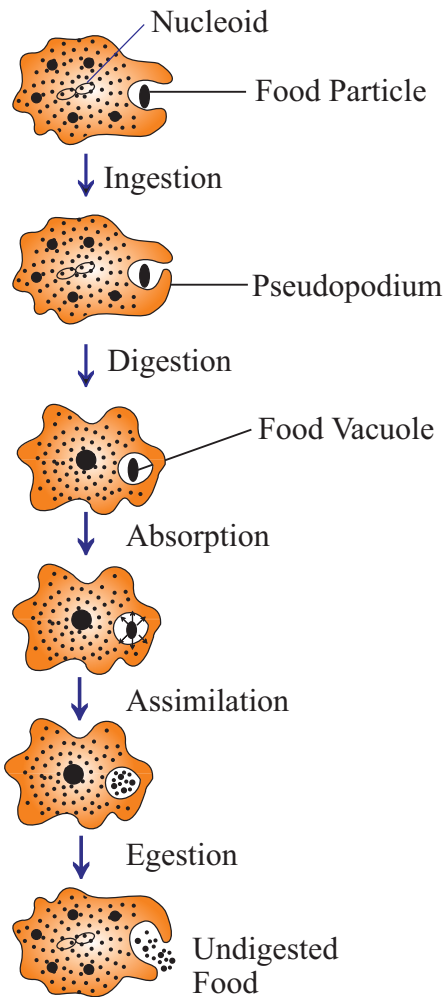

**NUTRITION
IN
AMOEBA**

(ii) Paramecium : Which is a unicellular organism takes in food at a specific spot which is moved there by cilia (small hair present all over the body).

Steps of Nutrition : (In Heterotrophs)

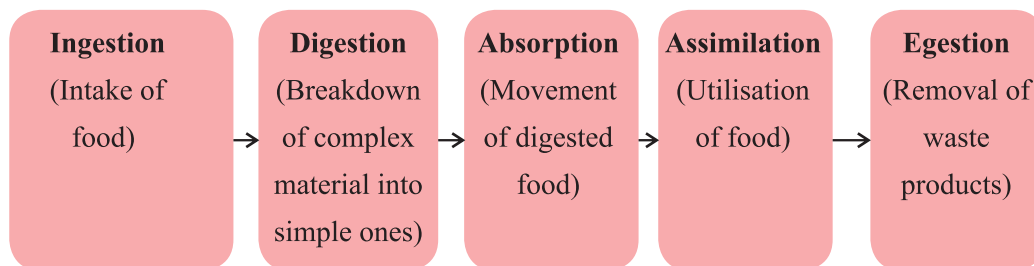

Nutrition in Human Beings

1.	<p>Mouth → Intake of whole food.</p> <p>Teeth → Chewing/grinding of food.</p> <p>Tongue → Rolling of food + Tasting of food + Swallowing/Pushing down of the food.</p> <p>Salivary Glands → Secrete saliva + Mucus</p> <p style="text-align: center;"> $\text{Starch} \xrightarrow[\text{[Saliva]}]{\text{Salivary amylase}} \text{Sugar}$ </p>									
2.	<p>Oesophagus → Taking food from mouth to stomach by Peristaltic movements. [Contraction and expansion of muscles of the oesophagus]</p>									
3.	<p>Stomach → Gastric glands $\xrightarrow{\text{Secrete}}$ Gastric juice</p> <p style="text-align: center;">Gastric Juice</p> <table style="margin-left: auto; margin-right: auto; border-collapse: collapse;"> <tr> <td style="text-align: center; border: none;">PEPSIN</td> <td style="text-align: center; border: none;">HCl</td> <td style="text-align: center; border: none;">MUCUS</td> </tr> <tr> <td style="text-align: center; border: none;">(Enzyme that breaks down proteins)</td> <td style="text-align: center; border: none;">(Makes medium acidic)</td> <td style="text-align: center; border: none;">(Protects inner lining of the stomach)</td> </tr> </table>	PEPSIN	HCl	MUCUS	(Enzyme that breaks down proteins)	(Makes medium acidic)	(Protects inner lining of the stomach)			
PEPSIN	HCl	MUCUS								
(Enzyme that breaks down proteins)	(Makes medium acidic)	(Protects inner lining of the stomach)								
4.	<p>Small Intestine → (a) Intestinal enzyme</p> <p style="text-align: center;">↓ convert</p> <table style="margin-left: auto; margin-right: auto; border-collapse: collapse;"> <tr> <td style="text-align: center; border: none;">Carbohydrate</td> <td style="text-align: center; border: none;">Fats</td> <td style="text-align: center; border: none;">Proteins</td> </tr> <tr> <td style="text-align: center; border: none;">↓</td> <td style="text-align: center; border: none;">↓</td> <td style="text-align: center; border: none;">↓</td> </tr> <tr> <td style="text-align: center; border: 1px solid black;">Glucose</td> <td style="text-align: center; border: 1px solid black;">Fatty acid + Glycerol</td> <td style="text-align: center; border: 1px solid black;">Amino acids</td> </tr> </table>	Carbohydrate	Fats	Proteins	↓	↓	↓	Glucose	Fatty acid + Glycerol	Amino acids
Carbohydrate	Fats	Proteins								
↓	↓	↓								
Glucose	Fatty acid + Glycerol	Amino acids								
5.	<p>Small Intestine → (b) Villi → Helps in absorption of digested food into the blood</p> <p style="margin-left: 20px;">(finger like projections)</p>									

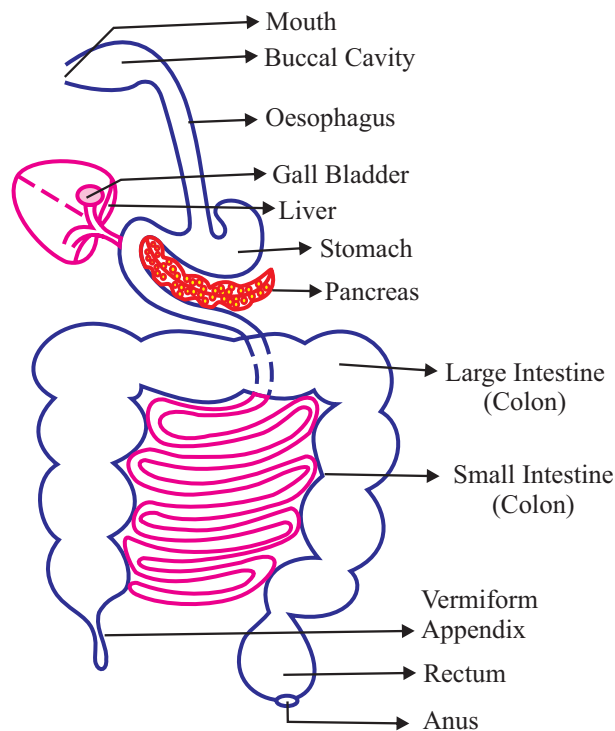
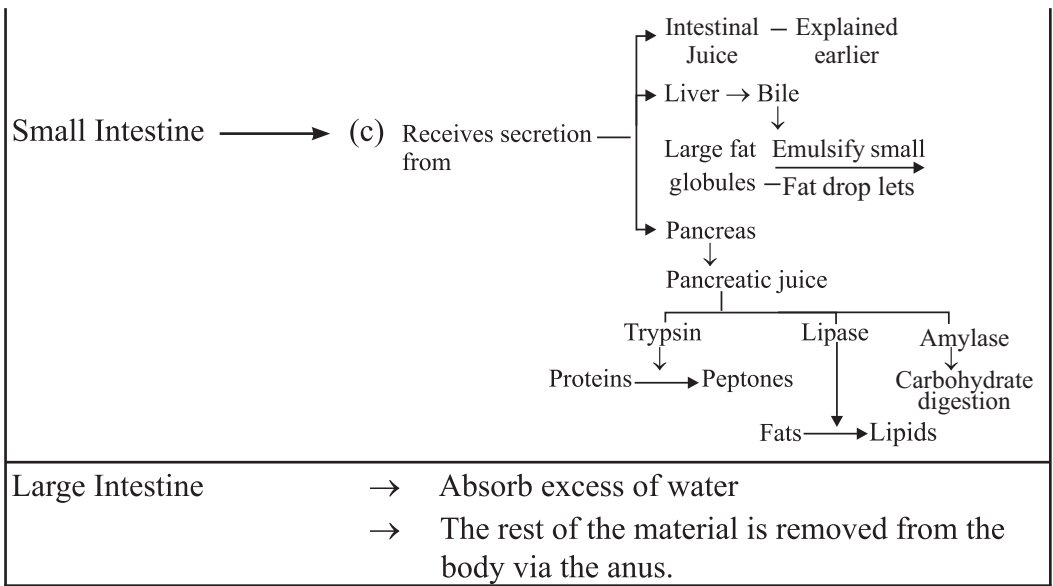

Human Digestive System

Digestive System = Alimentary Canal + Digestive Glands

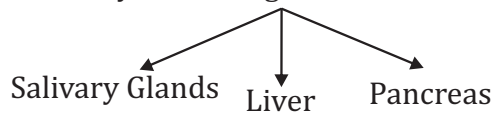

RESPIRATION

- Respiration involves :
- (i) Gaseous exchange : Intake of oxygen from the atmosphere and release of CO_2 → **Breathing**
 - (ii) Breakdown of simple food in order to release energy inside the cell → **Cellular respiration**

Breakdown of Glucose by Various Pathways

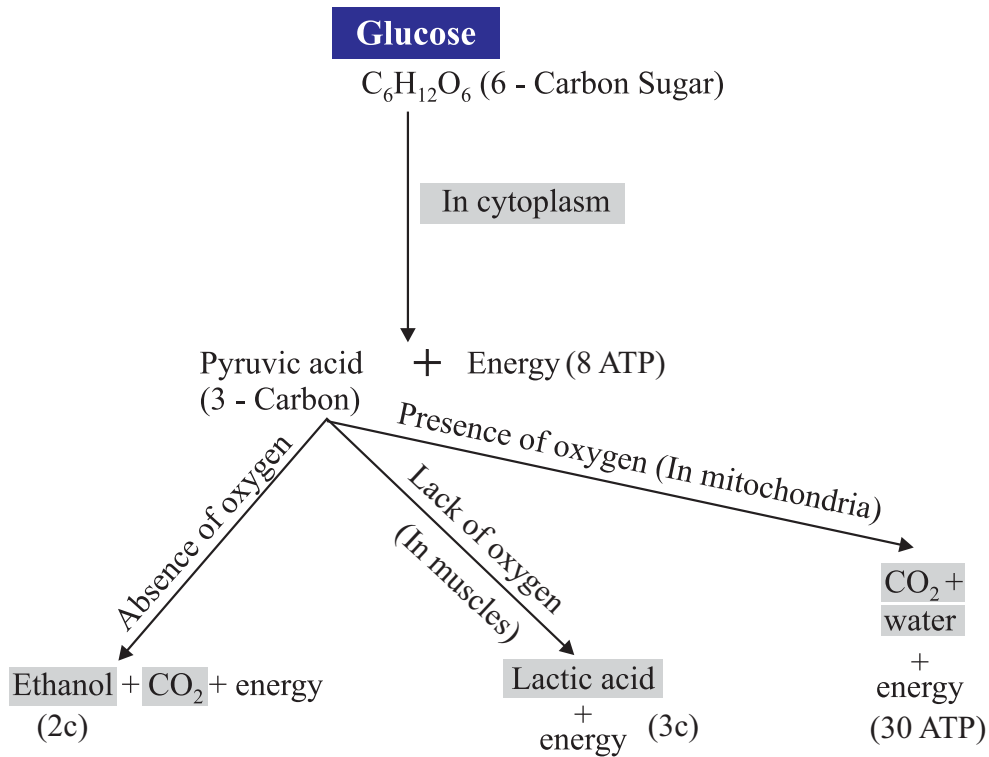

Respiration

Aerobic

- Takes place in the presence of oxygen
- Occurs in mitochondria
- End products are CO_2 and H_2O
- More amount of energy is released

Anaerobic

- Takes place in the absence of oxygen
- Occurs in cytoplasm
- End products are alcohol or lactic acid
- Less amount of energy is released

Human Respiratory System

Passage of air through the respiratory system :

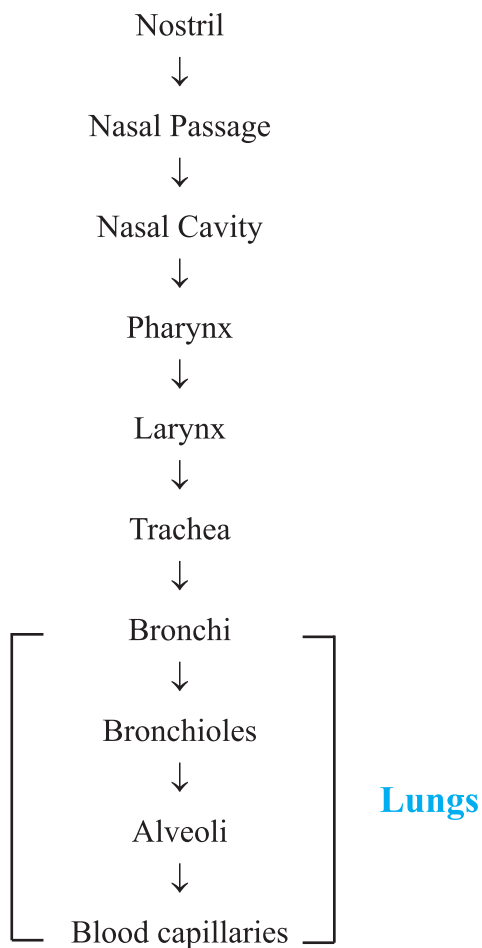

Mechanism of Breathing

Inhalation	Exhalation
<ul style="list-style-type: none">• During inhalation the thoracic cavity (chest cavity) expands.• Ribs lift up.• Diaphragm become flat in shape.• Volume of lungs increases and air enters the lungs	<ul style="list-style-type: none">• Thoracic cavity contracts.• Ribs move downwards.• Diaphragm becomes dome shaped.• Volume of lungs decreases and air exits from the lungs.

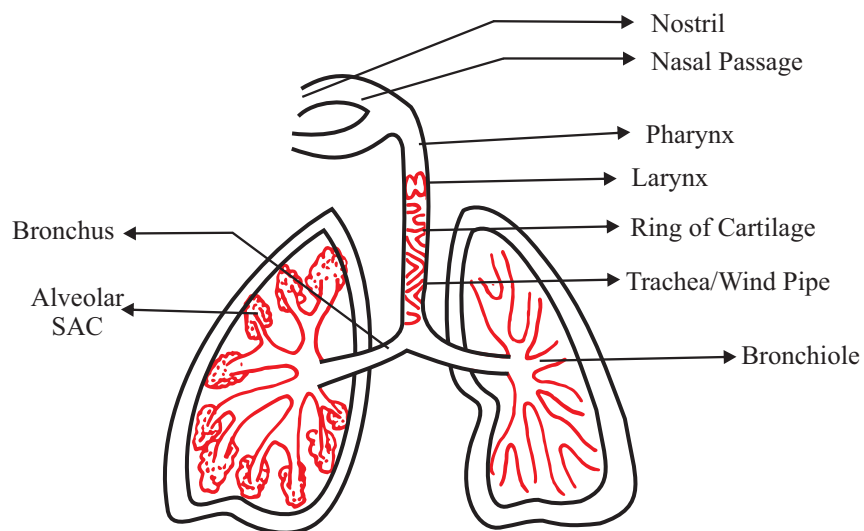

Human Respiratory System

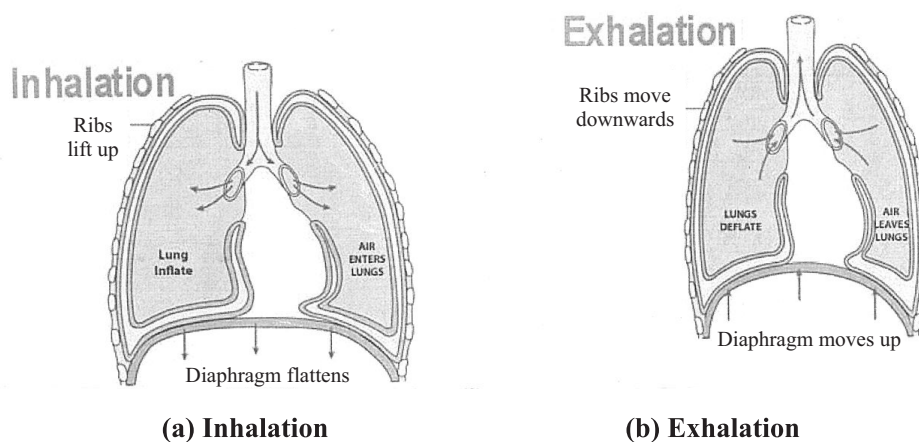

Exchange of gases between alveolus, blood and tissues

- (I) Air rich in O_2 (in alveolus) → Enters in blood (through blood vessels) → O_2 Binds with haemoglobin in RBC → O_2 released in tissues → Glucose Breakdown → CO_2 Production (in tissues)

(In tissues)
- (ii) CO_2 from tissues released in blood and gets dissolved → Carried through blood vessels → Released in Alveolar sac → Sent out through nostrils

Terrestrial organisms : Use atmospheric oxygen for respiration

Aquatic organisms : Use dissolved oxygen for respiration

Respiration in plants

Respiration in plants is simpler than the respiration in animals. Gaseous exchange occur through :

- (a) Stomata in leaves
- (b) Lenticels in stems
- (c) General surface of the root

Transportation

Human beings like other multicellular organism need regular supply of food, oxygen etc. This function is performed by circulatory system.

The circulatory system in human beings consists of

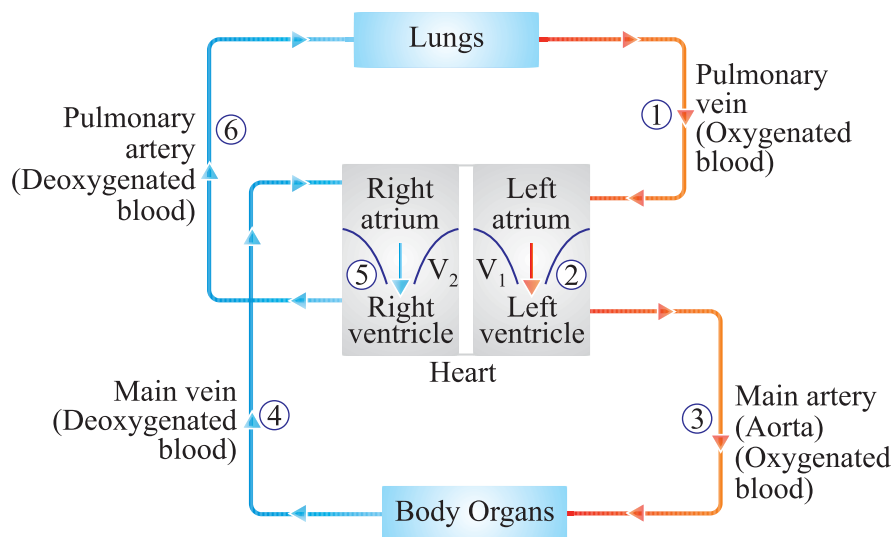
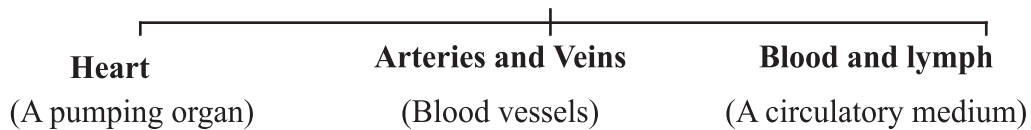
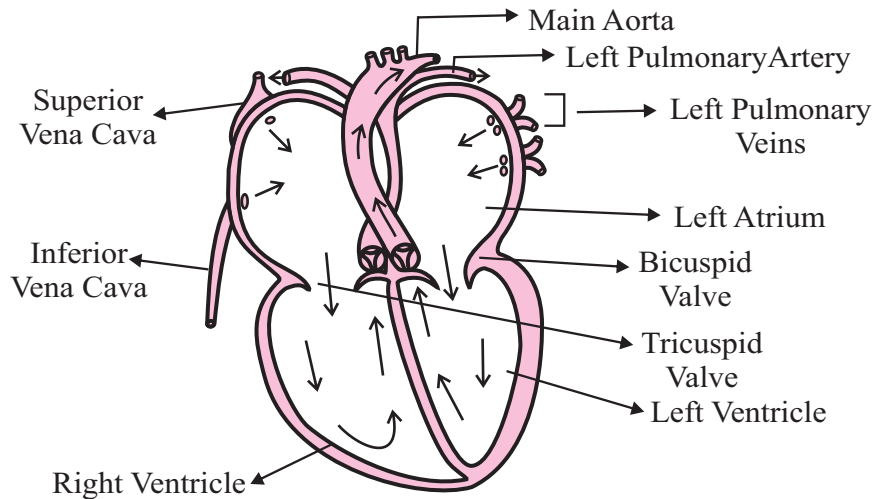

Diagram to show blood circulation in human body

Double circulation

Blood travels twice through the heart in one complete cycle of the body.



**Sectional View of Human Heart
Showing Direction of Blood Flow**

- **Pulmonary Circulation :** Blood moves from the heart to the lungs and back to the heart.
- **Systemic Circulation :** Blood moves from the heart to rest of the body and back to the heart.

Blood

(A fluid connective tissue)

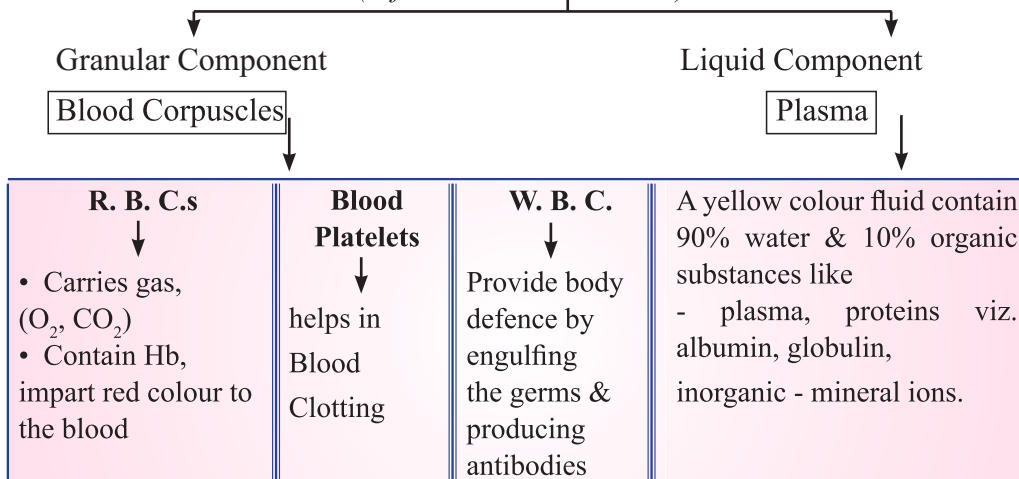

Lymph : A yellowish fluid escapes from the blood capillaries into the intercellular spaces, contains less proteins than blood. Lymph flows from the tissues to the heart, assisting in transportation and destroying germs.

Blood Vessels

Arteries

1. Carry oxygenated blood from heart to body parts except pulmonary artery.
2. Also called distributing vessel.
3. Thick and elastic.
4. Deep Seated

Veins

1. Carry deoxygenated blood from body parts to heart except pulmonary vein.
2. Also called collecting vessel.
3. Thin and less elastic.
4. Superficial as compared to arteries

Transportation in Plants

There are two main conducting pathways in a plant.

Xylem

1. Carries water & minerals from the roots to other parts of the plant.
2. No energy is used.

Phloem

1. Carries product of photosynthesis from leaves to the other parts of the plant.
2. Energy is used from ATP.

Transpiration is the process of loss of water as vapour from aerial parts of the plant.

Function :

- (a) Absorption and upward movement of water and minerals by creating osmotic pressure pull.
- (b) Helps in temperature regulation in plant.

Transport of food from leaves (food factory) to different part of the plant is called **Translocation**.

EXCRETORY SYSTEM IN HUMAN

Excretory/urinary system consists of :

- (1) The kidneys : The excretory organ
- (2) The ureters : The ducts which drain out urine from the kidneys
- (3) The urinary bladder : The urine reservoir
- (4) The urethra : The channel to the exterior

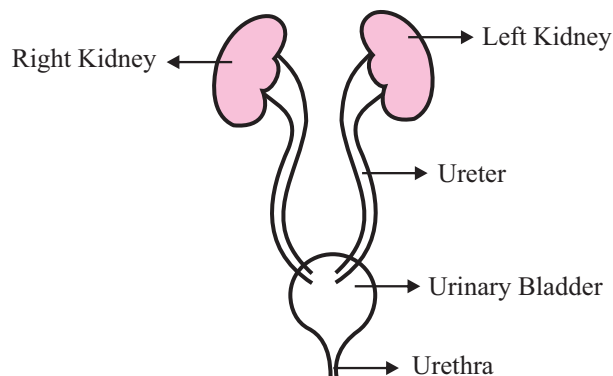

Excretory System in Human Beings

EXCRETION

1. The metabolic activities in the body generates many kinds of wastes including nitrogenous wastes which are harmful for the body and hence needed to be removed. Excretion is a process by which these wastes are removed from our body.

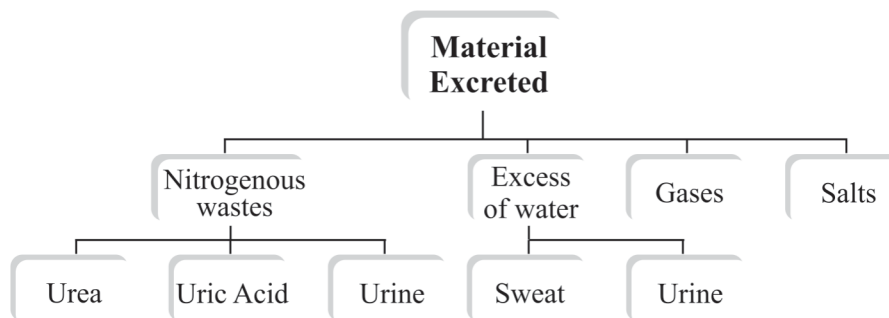

2. Unicellular organisms remove these wastes by simple diffusion.

Human Excretory System

1. It maintains water equilibrium, pH equilibrium, ionic equilibrium of the blood and osmotic equilibrium.
2. It helps to excrete out waste product urea in the dissolved form from the blood.
3. It excretes poisonous substance like drugs, toxins etc. from the body.
4. It regulates blood pressure by controlling The fluid balance in the body.

Formation of Urine

- Each kidney contains many filtration units called as nephrons.
- Nephrons are made up of a cluster of thin walled capillaries called glomerulus which is associated with a cup like structure called as Bowman's capsule and the long tube which terminates through this capsule.
- The renal artery brings oxygenated blood to the kidneys along with the nitrogenous wastes like urea and uric acid and many other substances.
- The blood gets filtered through the glomerulus and this filtrate enters the tubular part of nephron.
- As this filtrate moves down the tubular part, glucose, amino acids, salts and excess of water gets selectively reabsorbed by the blood vessels surrounding these tubules.
- The amount of water reabsorbed depends upon :
 - * How much excess of water is there in the body and,
 - * How much nitrogenous wastes need to be excreted out.
- So the fluid now flowing in the tubular part is urine which gets collected in collecting ducts of nephrons.
- These collecting ducts together leave the kidney at a common point by forming the ureter.
- Each ureter drains the urine in the urinary bladder where it is stored until the pressure of expanded bladder leads to an urge to pass it out through urethra.
- This bladder is a muscular structure which is under nervous control.
- 180 litres of filtrate is formed daily but only 2 litres is excreted out as urine so the rest is reabsorbed in the body.

Functions of Nephron

- Excretion of nitrogenous wastes.
- To maintain the water and ionic balance (osmotic regulation).

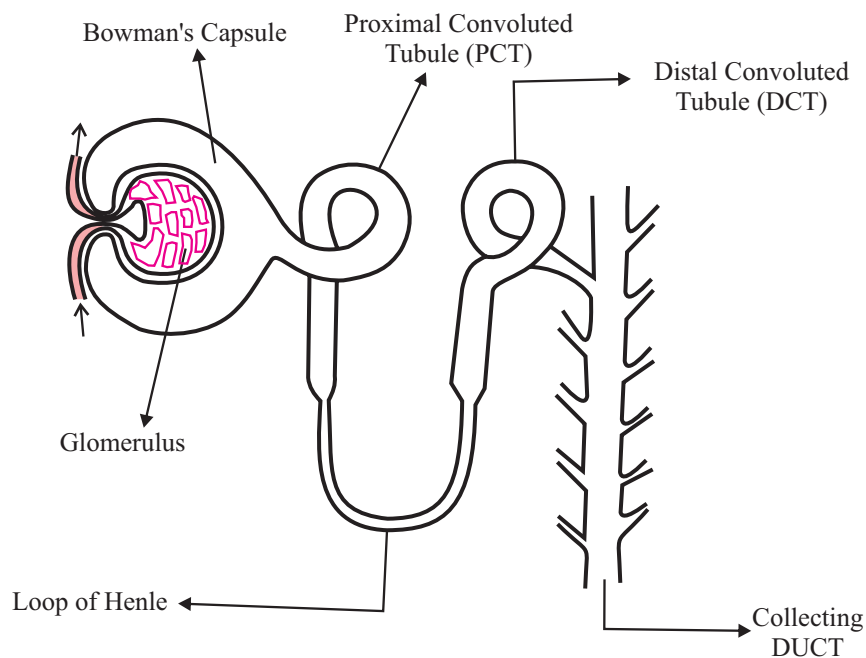

Structure of a Nephron

The urine formation involves three steps :

1. **Glomerular filtration** : Nitrogenous wastes, glucose water, amino acid filtered from the blood into Bowman Capsule of the nephron.
2. **Tubular reabsorption** : Now, useful substances from the filtrate are reabsorbed back by capillaries surrounding the nephron.
3. **Secretion** : Urea, extra water and salts are secreted into the tubule which open up into the collecting duct & then into the ureter.

Artificial Kidney

Haemodialysis : The process of purifying blood by an artificial kidney. It is meant for kidney failure patients.

Excretion in Plants

Plants use different strategies for excretion of different products :

- Oxygen and carbon dioxide is diffused through stomata.
- Excess water is removed by transpiration.
- Plants can even loose some of their old parts like old leaves and bark of tree.
- Other waste products like resins and gums especially in old xylem cells can also be lost by plants.
- Plants also excrete some waste substances into the soil around them.

VERY SHORT ANSWER TYPE QUESTIONS (1 MARK)

(A) Multiple Choice Questions (MCQ's)

1. Which is the first enzyme that gets mixed with food in the digestive tract?
(a) Pepsin (b) Cellulose
(c) Trypsin (d) Amylase
2. The opening and closing of the stomatal pore depends upon.
(a) Temperature (b) Oxygen
(c) Concentration of CO_2 in stomata (d) Water in guard cells
3. The parts A and B Shown in the given diagram are:

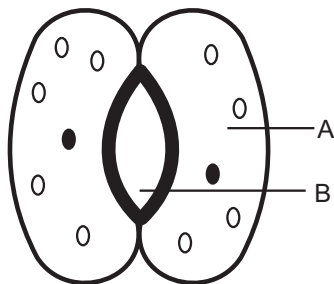

- (a) Guard cell and stomatal pore
- (b) Epidermal cell and stomatal pore
- (c) Epidermal cell and guard cell
- (d) Guard cell and epidermal cell

4. Complete the following reactions:
$$6\text{CO}_2 + 12\text{H}_2\text{O} \xrightarrow[\text{?}]{\text{Sunlight}} \text{C}_6\text{H}_{12}\text{O}_6 + 6\text{H}_2\text{O} + 6\text{O}_2$$
- (a) Mitochondria (b) Plastid
(c) Iodine (d) Chlorophyll
5. The energy currency of the cell is:
(a) ATP (b) AMP
(c) CO_2 (d) ADP
6. The blood leaving the tissues becomes richer in
(a) Carbon-di-oxide (b) Water
(c) Haemoglobin (d) Oxygen
7. The internal (cellular) energy reserve in autotrophs is
(a) Glycogen (b) Protein
(c) Starch (d) Fatty acid
8. During deficiency of oxygen in tissues of human beings, pyruvic acid is converted into lactic acid in the
(a) Cytoplasm (b) Chloroplast
(c) Mitochondria (d) Golgibody
9. What prevents backflow of blood inside the heart during contraction-
(a) Thin walls of atria
(b) Valves in heart
(c) Thick muscular walls of ventricles
(d) All of the above
10. Which of the following enzyme needs an acidic medium to be active
(a) Trypsin (b) Pepsin
(c) Lipase (d) None of the above
11. An organism which breaks down the food material outside the body and then absorbs it is (CBSE, 2022)
(a) a plant parasite, Cuscuta (b) an animal parasite, Tapeworm
(c) a bacteria, Rhizobium (d) a fungi, Rhizopus

12. Name a circulatory fluid in the human body other than blood
- (a) Platelets (b) RBC
(c) Lymph (d) Plasma
13. The respiratory pigment in human beings is
- (a) carotene (b) chlorophyll
(c) haemoglobin (d) mitochondria
14. Roots of the plant absorb water from the soil through the process of:
- (a) diffusion (b) transpiration
(c) osmosis (d) none of these
15. During respiration, exchange of gases takes place in
- (a) trachea and larynx (b) alveoli of lungs
(c) alveoli and throat (d) throat and larynx

Answers-

1. (d) 2. (d) 3. (a) 4. (d) 5. (a)
6. (a) 7. (c) 8. (a) 9. (b) 10. (b)
11. (d) 12. (C) 13. (C) 14. (C) 15. (b)

16. Name the tissue that transports water and minerals in plants.
17. What is the role of acid in our stomach ?
18. What is emulsification ?
19. Name the cell organelle in which photosynthesis occurs.
20. Name the largest artery in the human body.
21. Define transpiration.
22. What is the structural and functional unit of kidney called ?
23. In following questions two statements are given one labelled Assertion (A) and the other labelled Reason (R). Select the correct answer to these questions from the codes (a), (b), (c) and (d) as given below:
- (a) Both A and R are true, and R is correct explanation of the assertion.
(b) Both A and R are true, but R is not the correct explanation of the assertion.
(c) A is true, but R is false.
(d) A is false, but R is true.

- I. Assertion: Rate of breathing in aquatic organisms is slower than terrestrial organisms.
Reason: The amount of dissolved oxygen is fairly low as compared to amount of oxygen in air.
- II. Assertion: The effect of root pressure in transport of water is more important at night.
Reason: During the day the transpiration pull acts as major driving force in the movement of water in the system.
- III. Assertion: The opening and closing of the pore of stomata is a function of the guard cell.
Reason: The stomatal pore opens when water comes out of guard cells causing their shrinkage.
- IV. Assertion: Carnivores have a shorter small intestine.
Reason: Meat is easier to digest.
- V. Assertion: Plasma of blood transports food, carbon dioxide and nitrogenous wastes.
Reason: Red blood corpuscles carry oxygen.

Answer:

1. (d) 2. (a) 3. (c) 4. (a) 5. (b)

24 Read the following and answer questions given below:

There is a progressive change in structure of heart between vertebrates like fishes to birds & mammals. Fish have a simple two chambered heart. Amphibians possess three chambered heart with two atria and a single ventricle. Reptiles have a septum (wall) that partly divides the ventricle. Birds and mammals have the four chambered design.

- In fishes blood flows from heart to gills to body and back to heart. This is example of
 - Single circulation
 - double circulation
 - Triple circulation
 - circulation
- Which of the following organisms shows mixing of oxygenated and deoxygenated blood-
 - Pigeon
 - Fish
 - Frog
 - Crocodile
- Birds and mammals have four-chambered hearts as it leads to separation of oxygenated and deoxygenated blood. Such a separation allows-
 - Highly efficient supply of oxygen to the body

8. Explain the three pathways of breakdown of glucose in living organisms.
9. How is small intestine designed to absorb digested food.
10. Describe the process of double circulation in human beings.
11. Define the term transpiration. Design an experiment to demonstrate this process. (CBSE 2018-19)

LONG ANSWER TYPE QUESTION (5 MARKS)

1. i) Write three types of blood vessels. Give one important feature of each (CBSE, Delhi 2018-19)
ii) How are CO_2 and O_2 transported in human beings? (CBSE 2018-19)
2. Write the function of the following in the human alimentary canal. (CBSE 2018-19)
i) Saliva ii) HCl in Stomach iii) Bile juice iv) Villi
3. Write one function of each of the following enzymes.
i) Pepsin ii) Lipase
4. Draw a well labelled diagram of Nephron. Explain the process of formation of urine in the human kidney.
5. Why energy needs in plants are very less as compared to animals? Explain.
6. Draw the diagram showing Human Respiratory System. Label the following parts.
a) Alveolus
b) Trachea
c) Bronchus
d) Lungs

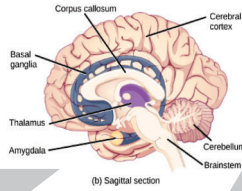

Chapter-6

Control And Coordination

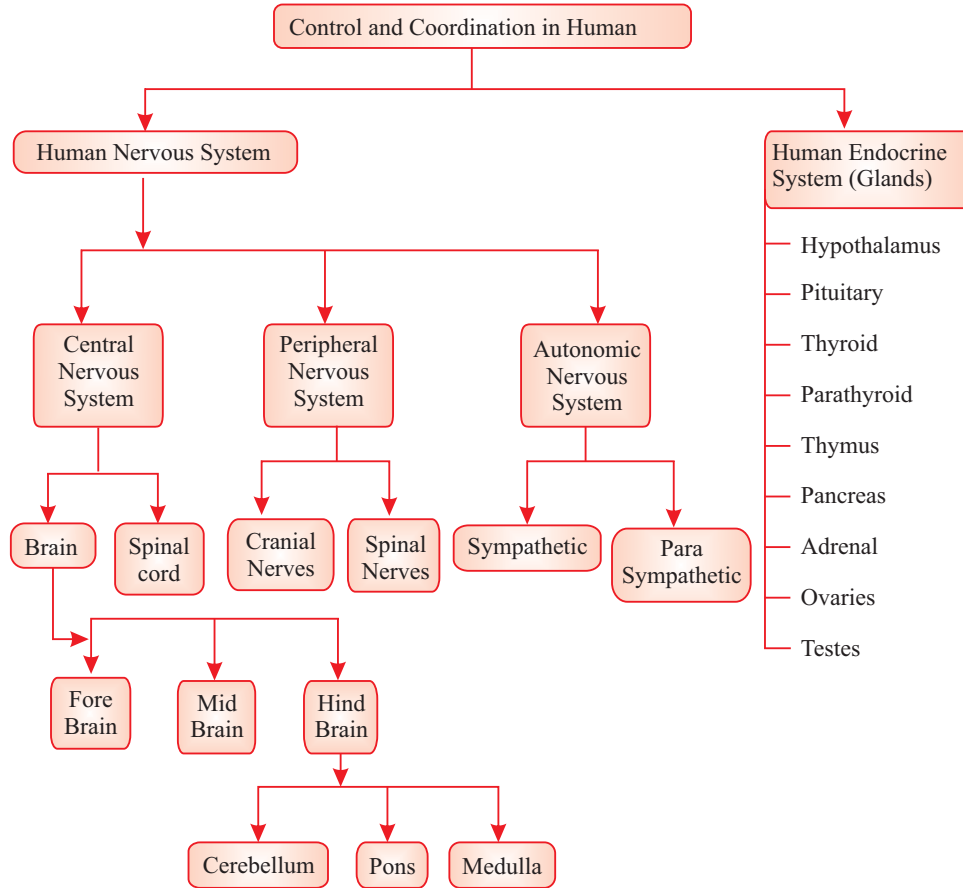

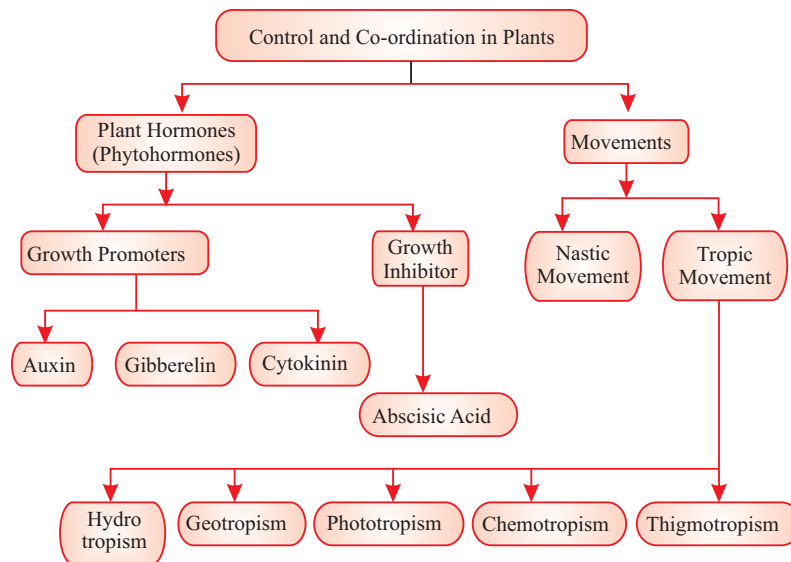

- All the living organisms respond and react to changes in the environment around them.
- The changes in the environment to which the organisms respond and react are called stimuli such as light, heat, cold, sound, smell, touch etc.
- Both plants and animals respond to stimuli but in a different manner.

Control and Coordination in Animals

It is brought about in all animals with the help of two main systems :

- Nervous system
- Endocrine system

NERVOUS SYSTEM

- Control and coordination are provided by nervous and muscular tissues.
- Nervous tissue is made up of an organized network of nerve cells or neurons, and is specialized for conducting information via electrical impulses from one part of the body to another.

Receptors : Are specialized tips of some nerve cells that detect the information from the environment. These receptors are located in our sense organs.

- Ear :**
 - Phonoreceptors
 - Hearing
 - Balance of the body

- (b) **Eyes :**
 - Photoreceptors
 - Seeing
- (c) **Skin :**
 - Thigmoreceptors
 - Heat or cold
 - Touch
- (d) **Nose :**
 - Olfactory receptors
 - Smell detection
- (e) **Tongue :**
 - Gustatory receptors
 - Taste detection

Neuron : It is the structural and functional unit of nervous system.

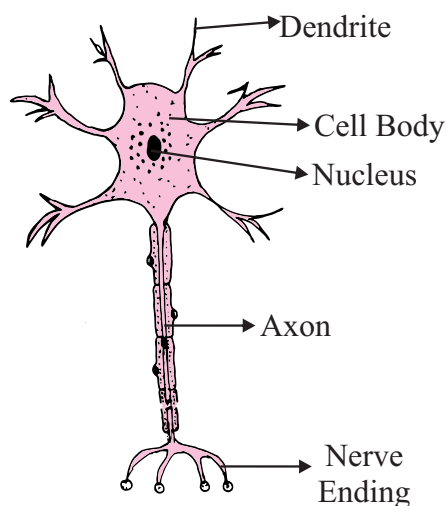

(a) Structure of Neuron

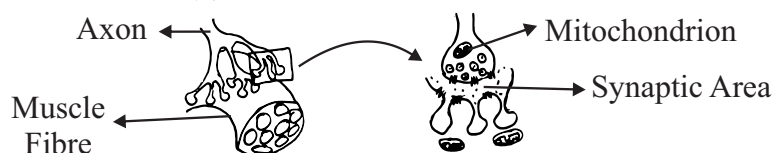

(b) Neuromuscular Junction

Parts of Neuron :

- (a) **Dendrite :** Acquires information.
- (b) **Cell body :** Acquired information travels as an electrical impulse.
- (c) **Axon :** Longest fibre on the cell body is called axon. It transmits electrical impulse from cell body to dendrite of next neuron.

Synapse : It is the gap between the nerve ending of one neuron and dendrite of the other neuron. Here electrical signal is converted into chemical signal for onward transmission.

REFLEX ACTION

Reflex action is quick, sudden and immediate response of the body to a stimulus.
E.g., Knee jerk, withdrawal of hand on touching hot object.

Reflex arc : The pathway through which nerve impulses pass during reflex action is called reflex arc.

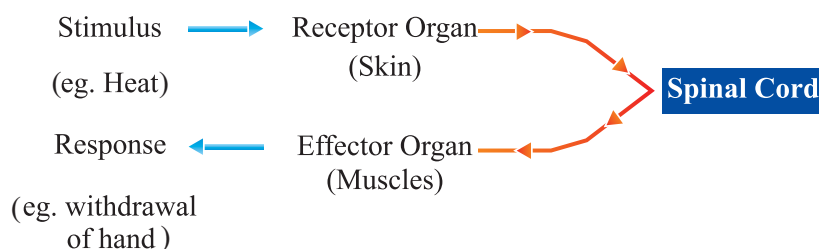

Response : Responses are of three main types :

- (a) **Voluntary :** Controlled by fore brain. *E.g.*, talking, writing.
- (b) **Involuntary :** Controlled by mid and hind brain. *E.g.*, heart beat, vomiting, respiration.
- (c) **Reflex action :** Controlled by spinal cord. *E.g.*, withdrawal of hand on touching a hot object.

Need of Reflex Actions : In some situations such as touching a hot object, pinching etc. we need to act quickly, otherwise our body would be harmed. Here response is generated from spinal cord instead of brain.

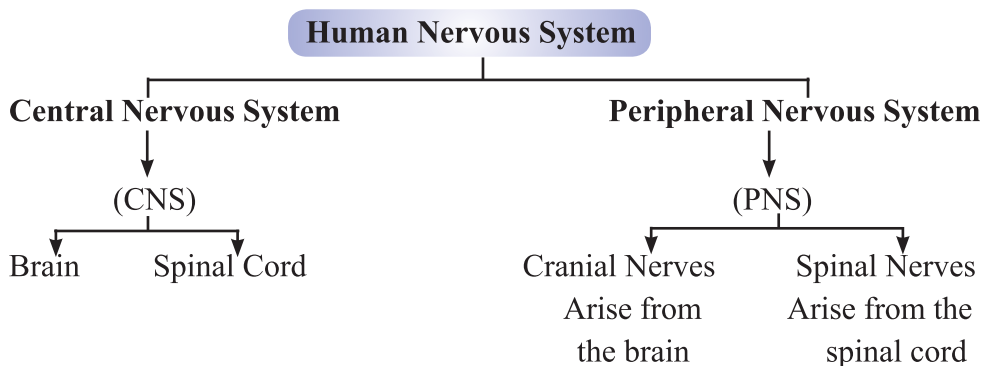

Protection of Brain and Spinal Cord

- (a) **Brain** : Brain is protected by a fluid filled balloon which acts as shock absorber and is enclosed in cranium (skull or brain box).
- (b) **Spinal Cord** : Spinal cord is enclosed in vertebral column.

Coordination between Nervous and Muscular Tissue

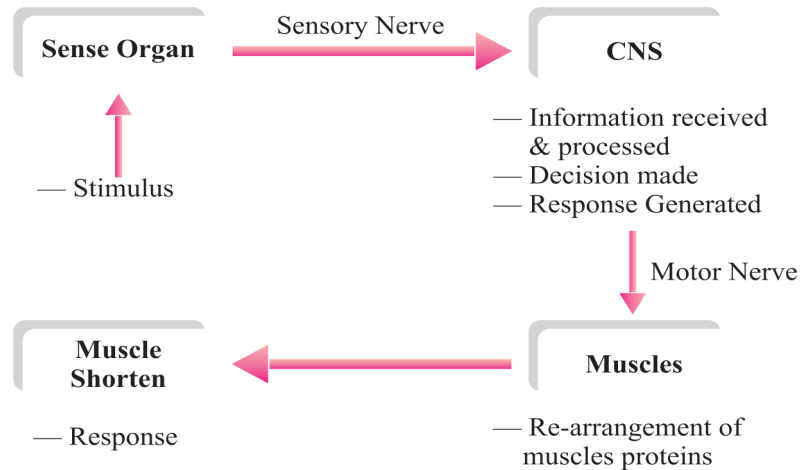

Limitations of Electric communication/Nervous system :

- (a) Electric impulse will reach only to those cells that are connected by nervous tissue.
- (b) After generation and transmission of an electrical impulse, the cell takes some time to reset its mechanism before transmitting another impulse. So cells cannot continually create and transmit impulse.
- (c) Plants do not have any nervous system.

Chemical communication : To overcome the limitations of electric communication.

COORDINATION IN PLANTS

Movements in plants :

- (i) Independent of growth
- (ii) Dependent on growth

(i) Independent of growth : Immediate response to stimulus. (Nastic Movement)

- Plants use electrical-chemical means to convey information from cell to cell.
- For movement to happen, cells change their shape by changing the amount of water in them, resulting in swelling or shrinking of cells.

E.g., Drooping of leaves of 'Touch-me-not' plant on touching it.

(ii) Dependent on growth : These movements are tropic movements i.e., directional movements in response to stimulus.

- **Tendrils :** The part of tendril away from the object grows more rapidly as compared to the part near the object. This causes circulation of tendril around the object.
- **Phototropism :** Movement towards light, e.g. growth of a shoot towards light.
- **Geotropism :** Movement towards/away from gravity, e.g. growth of roots in soil
- **Chemotropism :** Movement towards/away from Chemical e.g. Growth of pollen tube towards ovule.
- **Hydrotropism :** Movement towards water. e.g. growth of a roots towards water

Plant Hormones : Are chemical compounds which help to coordinate growth, development and responses to the environment.

Main plant hormones are :

- (a) Auxin :**
 - Synthesized at shoot tip
 - Helps the cells to grow longer
 - Involved in phototropism
- (b) Gibberellin :**
 - Helps in the growth of the stem
- (c) Cytokinins :**
 - Promotes cell division
 - Present in greater concentration in fruits and seeds
- (d) Abscisic Acid :**
 - Inhibits growth
 - Cause wilting of leaves
 - Stress hormone

Hormones in Animals :

Hormones : Hormones are the chemical substances which coordinate the activities of living organisms and also their growth.

Endocrine glands : These glands secrete their product (hormone) into the blood.

Endocrine Gland, Hormones and their Functions

S. No.	Hormone	Endocrine Gland	Location	Functions
1.	Thyroxine	Thyroid	Neck/Throat region	Regulation of metabolism of carbohydrates, fats and proteins.
2.	Growth hormone	Pituitary (master gland)	Mid brain	Regulates growth and development.
3.	Adrenaline	Adrenal	Above both kidneys	Regulation (increasing) of blood pressure, heart beat, carbohydrate metabolism (during emergency)
4.	Insulin	Pancreas	Below stomach	Reduces and regulates blood sugar level
5. Sex Hor- mone	(a)Testosterone in males (b)Estrogen in females	Testis Ovaries	Genital/lower abdomen area	Changes associated with puberty (Sexual maturity)
6.	Releasing Hormone	Hypothalamus	Mid brain	Stimulates pituitary gland to release hormones

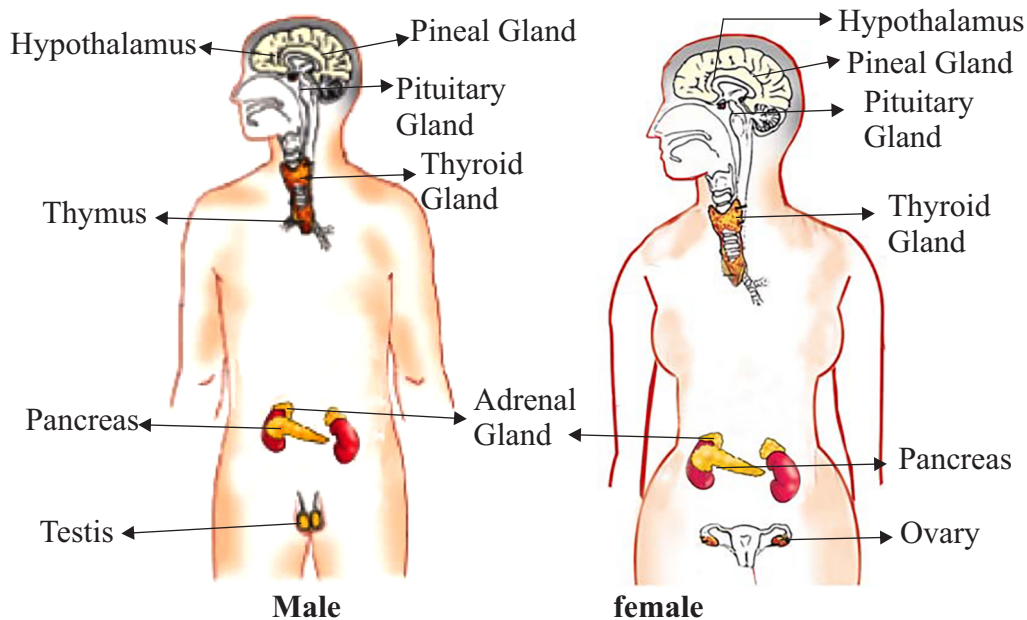

Human Endocrine Glands

Iodised salt is necessary because iodine mineral is essential part of thyroxine hormone secreted by thyroid gland. Thyroxine regulates metabolism of carbohydrates, fats and proteins. So, we must consume iodised salt which is necessary for proper working of thyroid gland. Its deficiency causes a disease called goitre (Swollen neck).

Diabetes

Disease in which blood sugar level increases.

Cause : Due to the deficiency of insulin hormone secreted by pancreas that is responsible to control blood sugar levels.

Treatment : Injections of insulin hormone.

Feedback Mechanism

The excess or deficiency of hormones has a harmful effect on our body. Feedback mechanism makes sure that hormones should be secreted in precise quantity and at right time.

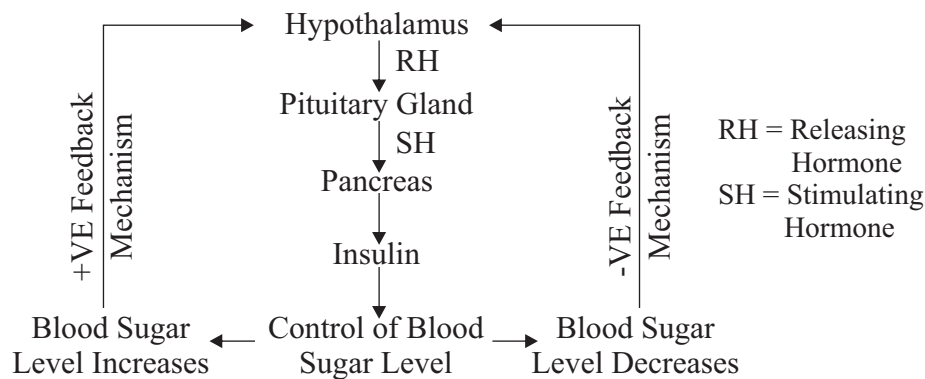

Feedback Mechanism to Control the Sugar Level in Blood

Very Short Answer Type Questions (1 Mark)

MCQs

1. Centre for hunger is situated in-
 - a) Fore-Brain
 - b) Mid-Brain
 - c) Hind-Brain
 - d) All of the above
2. Which is the main co-ordinating centre of the body.
 - a) Nerves
 - b) Spinal Card
 - c) Brain
 - d) Heart
3. Spinal cord originates from-
 - (a) Cerebrum
 - (b) Medulla
 - (c) Pons
 - (d) Cerebellum
4. The movement of shoot towards light is
 - (a) Geotropism
 - (b) hydrotropism
 - (c) Chemotropism
 - (d) Phototropism
5. Choose the incorrect statement about insulin
 - (a) It is produced from pancreas
 - (b) It regulates growth and development of the body
 - (c) It regulates blood-sugar level
 - (d) Insufficient secretion of insulin will cause diabetes
6. Which phytohormone is responsible for wilting of leaves-
 - (a) Auxin
 - (b) Absciscic acid
 - (c) Cytokinin
 - (d) Gibberellin

7. Which of the following is not an effect produced after secretion of adrenalin into the blood-
 - (a) Blood supply to the digestive system & skin is reduced
 - (b) Heart beats faster
 - (c) Breathing rate increases
 - (d) Blood supply to skeletal muscles is reduced
8. Which part of the brain is responsible for involuntary actions like blood-pressure, vomiting etc.

(a) Pons	(b) Cerebrum
(c) Medulla	(d) Cerebellum
9. Dwarfism results due to
 - (a) Less secretion of growth hormone
 - (b) Less secretion of adrenaline
 - (c) Excess secretion of growth hormone
 - (d) Less secretion of thyroxin
10. Which of the following endocrine gland is unpaired-

(a) Adrenal	(b) Testes
(c) Pituitary	(d) Ovary

Answer :

- | | | | | |
|--------|--------|--------|--------|---------|
| 1. (a) | 2. (c) | 3. (b) | 4. (d) | 5. (b) |
| 6. (b) | 7. (d) | 8. (c) | 9. (a) | 10. (c) |

11. In a neuron, where is impulse converted into chemical signal for onward transmission?
12. Name the two parts of Human nervous system.
13. What is the basic structural and functional unit of nervous system?
14. Where is auxin synthesized in plants ?
15. Which gland is known as master gland ?
16. Name the hormone that regulates blood sugar level.
17. What is synapse ?
18. What are tropic movements ?

19. Which part of the brain is responsible for maintaining posture and balance of our body ?
 20. Which hormone has inhibiting effects on growth of plants ?
 21. What is phototropism ?
 22. What are the components of central nervous system ?
 23. What happens at synapse between two neurons ?
 24. In following questions two statements are given one labelled Assertion (a) and the other labelled Reason (R). Select the correct answer to these questions from the codes (a), (b), (c) and (d) as given below:
 - (a) Both A and R are true, and R is correct explanation of the assertion.
 - (b) Both A and R are true, but R is not the correct explanation of the assertion.
 - (c) A is true, but R is false.
 - (d) A is false, but R is true.
- I. **Assertion :** It is important to have iodised salt in our diet.
Reason: Iodine is necessary for thyroid gland to make thyroxin hormone.
 - II. **Assertion :** Reflex arcs have evolved in animals
Reason: The thinking process of the brain is not fast enough.
 - III. **Assertion :** The brain sits inside a bony box
Reason: Brain, a delicate organ, is very important for organisms.
 - IV. **Assertion :** Auxin helps the cells of stem grow longer
Reason: Auxin is a growth inhibitor.
 - V. **Assertion :** The hormones should be secreted in precise quantities
Reason: Feedback mechanism operates in body to control hormone secretion

Answer:

1. (a) 2. (a) 3. (a) 4. (c) 5. (a)

Case-Study

25. Read the following and answer the questions:

The nervous tissue is made up of an organised network of nerve cells or neurons and is specialized for conducting information via electrical impulses from one part of the body to another.

- Which part of the neuron acquires the information
 - Dendrite
 - Cell body
 - Axon
 - Nerve ending
- Junction between two neurons is called
 - Cell junction
 - Neuro-muscular junction
 - Neural joint
 - Synapse
- Identify the diagram
 - Neural joint
 - Neuro-muscular junction
 - Cell junction
 - None of the above
- In a neuron, conversion of electrical signal to a chemical signal occurs at/in
 - Cell body
 - Axonal end
 - Dendritic end
 - None of the above
- The neurons that carry signals from spinal cord to muscles are
 - Sensory neuron
 - Motor neuron
 - Relay neuron
 - None of the above

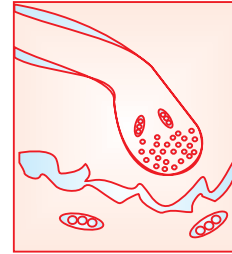

Answer:

1. (a) 2. (d) 3. (b) 4. (b) 5. (b)

SHORT ANSWER TYPE QUESTIONS (2 AND 3 Marks)

- Draw a labelled diagram of neuron.
- What is reflex arc ? Explain with the help of flow chart.
- What is the cause of diabetes ? How it can be controlled ?
- Why is it advisable to use iodised salt ?
- What are sensory and motor neurons ? Write their functions.
- Why is Abscisic acid called as stress hormone ?
- What is the need for a system of control and coordination in an organism?

8. List two different functions performed by pancreas (CBSE-2019)
9. What are plant hormones ? Name a plant hormone that promotes growth in plants.
10. What is the significance of tropic movements in plants ? Explain any two types of tropic movements.
11. Which hormone is known as emergency hormone in our body ? How it helps in coping during emergency ?
12. Where are different receptors present in our body ? What are their functions ?
- 13 Trace the sequence of events which occur when a bright light is focused on your eyes. (CBSE-2019)

MCQs

1. Which plant hormone promotes dormancy in seeds and buds?
 - (a) Auxin
 - (b) Gibberellin
 - (c) Cytokinin
 - (d) Abscisic acid
2. Roots of plants are:
 - (a) Positively geotropic
 - (b) Negatively geotropic
 - (c) Positively phototropic
 - (d) None of these
3. Response of plant roots towards water is called:
 - (a) Chemotropism
 - (b) Phototropism
 - (c) Hydrotropism
 - (d) Geotropism
4. Movement of sunflower in accordance with the path of sun is due to
 - (a) Chemotropism
 - (b) Geotropism
 - (c) Phototropism
 - (d) Hydrotropism

5. The main function of abscisic acids in plants is
- (a) To promote cell division
 - (b) To inhibit growth
 - (c) To promote growth of stem
 - (d) To increase the length of cells
6. Fall of mature leaves and fruits from plants is triggered by which of the following substance?
- (a) Auxin
 - (b) Cytokinin
 - (c) Gibberellin
 - (d) Abscisic acid
7. Any change in the environment to which an organism responds is called
- (a) Stimulus
 - (b) Coordination
 - (c) Response
 - (d) Hormone
8. The longest fibre or extension from the cell body of a neuron is called
- (a) Sheath
 - (b) Cytoplasm
 - (c) Axon
 - (d) Dendrites
9. A microscopic gap between a pair of adjacent neurons across which nerve impulses pass is called.
- (a) Neurotransmitter
 - (b) Dendrites
 - (c) Axon
 - (d) Synapse

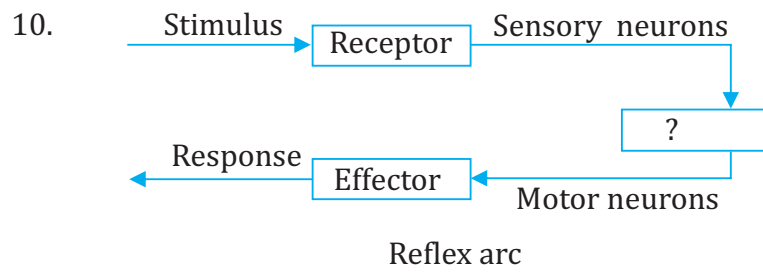

Give the missing term

- (a) Spinal cord
- (b) Brain
- (c) Cranial nerves
- (d) Relay nerves

- Ans.** (1) D (2) A (3) C (4) C
 (5) B (6) D (7) A (8) C
 (9) D (10) A

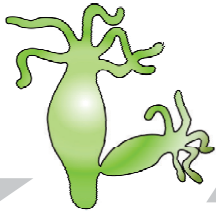

Chapter - 7

How do Organisms Reproduce

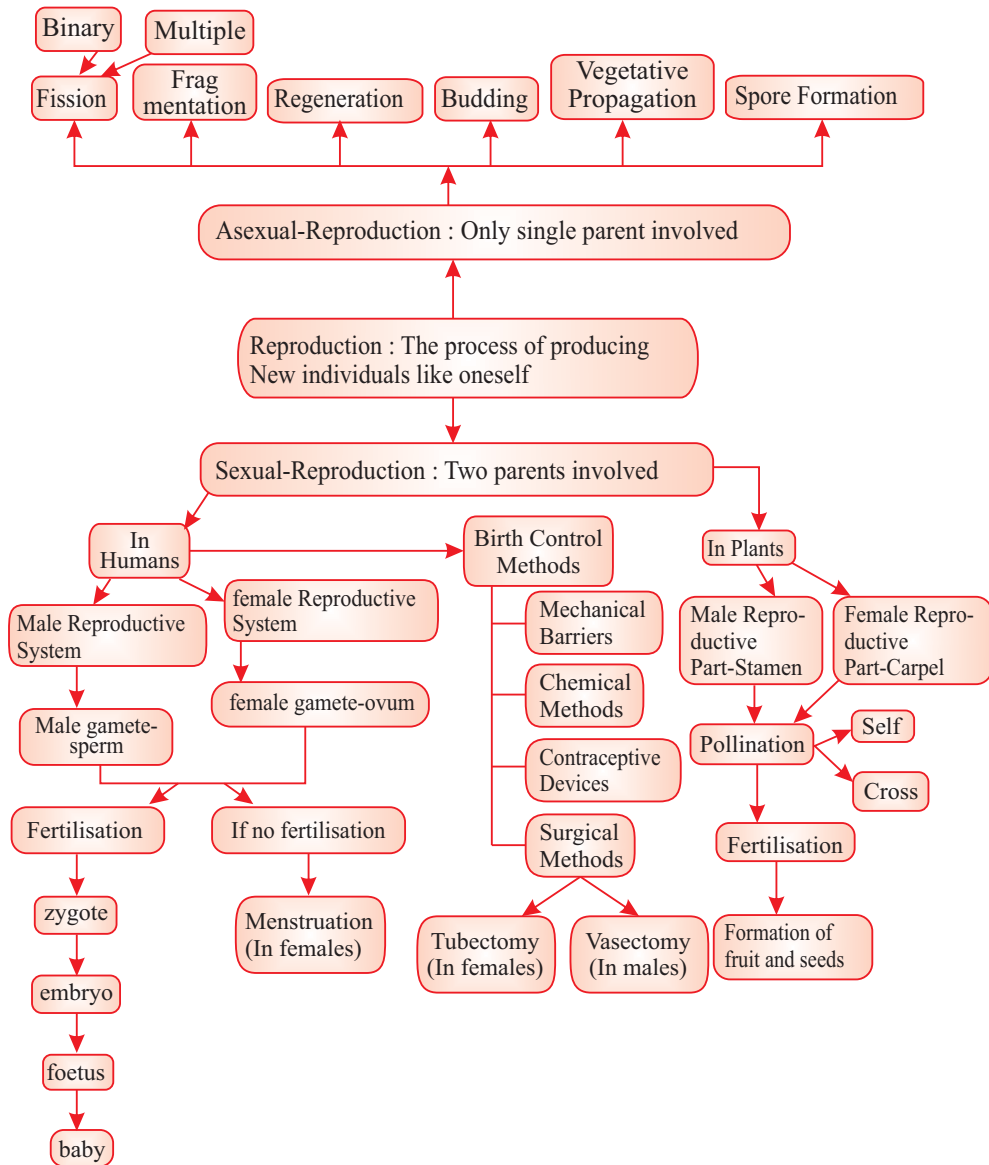

- Reproduction is the process by which living organisms produce new individuals similar to themselves. It ensures continuity of life on earth.
- Nucleus of the cell contains DNA (Deoxyribonucleic Acid, Nucleic Acid) which is the hereditary material.
- DNA replicates and forms new cells causing variation. So, these new cells will be similar but may not be identical to original cell.
- Variations are useful for the survival of the individual and species over time as well as basis for evolution.

Types of Reproduction

(a) Asexual Reproduction

- A single individual gives rise to new individual.
- Gametes are not formed.
- New individual is identical to parent.
- It is extremely useful as a means of rapid multiplication.
- Adopted by lower organisms.

(b) Sexual Reproduction

- Two individuals i.e., one male and one female are needed to give rise to new individual.
- Gametes are formed.
- New individual is genetically similar but not identical to parents.
- It is useful to generate more variations in species.
- Adopted by higher organisms.

Modes of Asexual Reproduction

(i) **Fission** : The parent cell divides into daughter cells.

- **Binary fission** : 2 cells are formed. *E.g.*, Amoeba.
- **Multiple fission** : Many cells are formed. *E.g.*, Plasmodium.

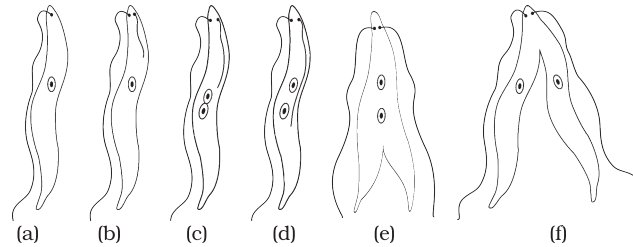

Binary fission in Leishmania

(ii) **Fragmentation** : The organism breaks-up into smaller pieces upon maturation, each piece develops into new individual. *E.g.*, Spirogyra.

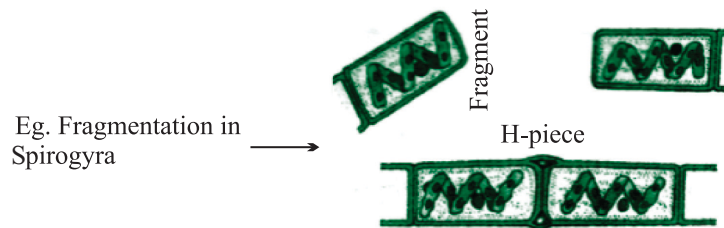

Fragmentation in Spirogyra

(iii) **Regeneration** : If organism is somehow cut or broken into many pieces, each piece grows into a complete organism. *E.g.*, Planaria, Hydra.

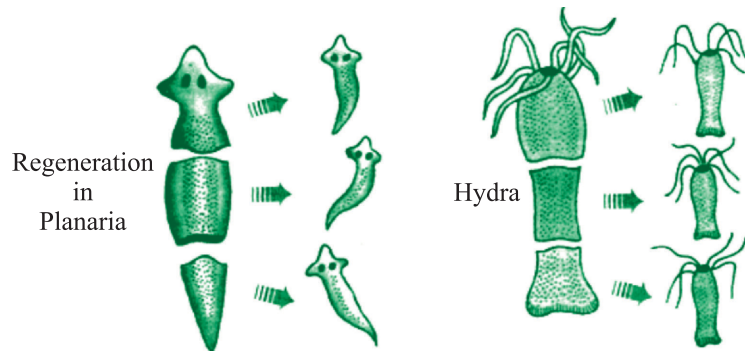

Regeneration in Planaria and Hydra

(iv) **Budding** : A bud is formed which develops into tiny individual. It detaches from parent body upon maturation and develops into new individual. *E.g.*, Hydra

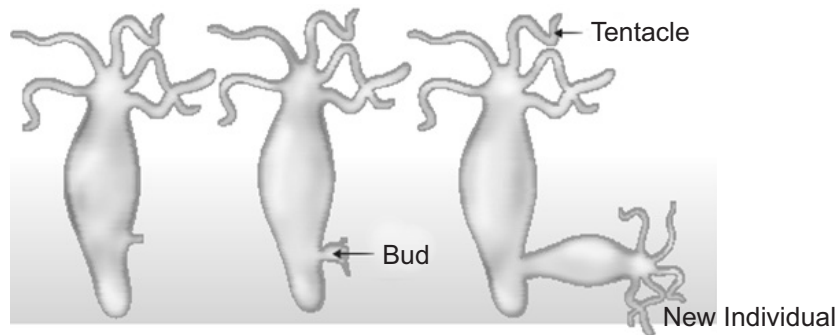

Budding in Hydra

(v) **Vegetative Propagation** : In many plants, new plants develop from vegetative parts such as :

- By roots : *E.g.*, dahlias, sweet potato.
- By stem : *E.g.*, potato, ginger.
- By leaves : *E.g.*, bryophyllum (leaf notches bear buds which develop into plants).
- Artificial methods :

(a) Grafting : *E.g.*, Mango

(b) Cutting : *E.g.*, Rose

(c) Layering : *E.g.*, Jasmine

(d) **Tissue culture** : New plants are grown by using growing tip of a plant. These growing cells are kept in a culture medium leads to the formation of callus. Callus is then transferred to hormone medium which causes growth and differentiation. *E.g.*, ornamental plants, orchid.

Benefits of tissue culture :

- We can grow plants like banana, rose, jasmine etc. that have lost the capacity to produce seeds.
- New plants are genetically similar to parents.
- Helps in growing seedless fruits.

(vi) **Spore Formation** : Spores are small bulb like structures which are covered by thick walls. Under favourable conditions, they germinate and produce new organism.

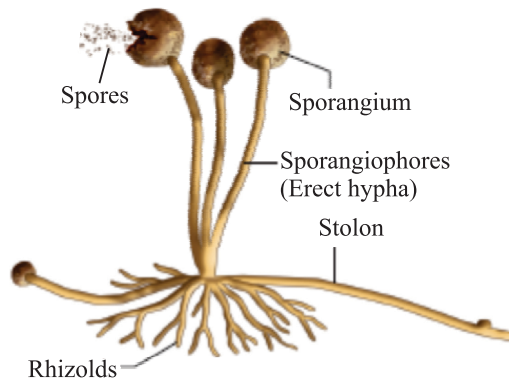

Spore formation in Rhizopus

Sexual Reproduction

When reproduction takes place as a result of the fusion of male and female gametes is called sexual reproduction.

Fusion of gametes is called fertilization which results in variation.

Sexual Reproduction in Plants

- Flowers are the reproductive organs of plants.
- A typical flower consists of four main whorls namely sepals, petals, stamen and pistil.

Types of Flowers

- **Bisexual flower** : Both male and female reproductive parts are present.
E.g., Hibiscus, mustard.
- **Unisexual flower** : Either male or female reproductive part is present.
E.g., Papaya, watermelon.

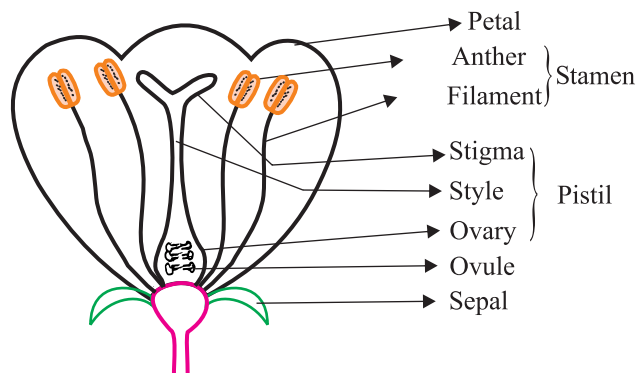

Longitudinal Section of Flower

Process of Seed Formation

- Pollen grains, produced in the anther, are transferred to the stigma of same flower (self pollination) or stigma of another flower (cross pollination) through agents like air, water or animals.
- Pollen grains germinate and form pollen tubes which pass through style to reach upto the ovules present in ovary.
- The fusion of male and female gametes is called fertilization. Zygote is produced inside the ovary.
- Zygote divides to form embryo. Ovule develops thick coat and changes into seed gradually.
- Ovary changes into fruit and other parts of flower fall off.

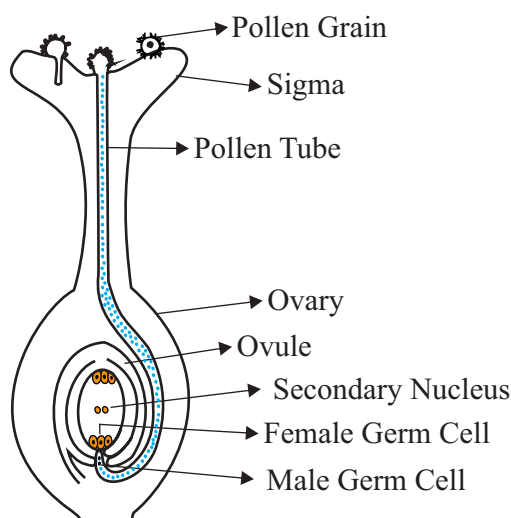

Germination of pollen on stigma

- The seed germinates to form a plant under suitable conditions such as air, moisture etc.

Double Fertilisation :

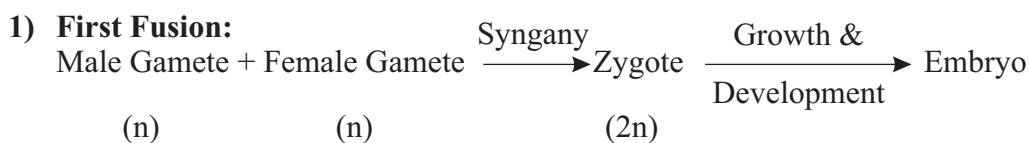

(d) Associated glands : Seminal vesicles and prostate gland add their secretion to the sperms. This fluid provide nourishment to sperms and make their transport easy.

Sperm alongwith secretion of glands form semen.

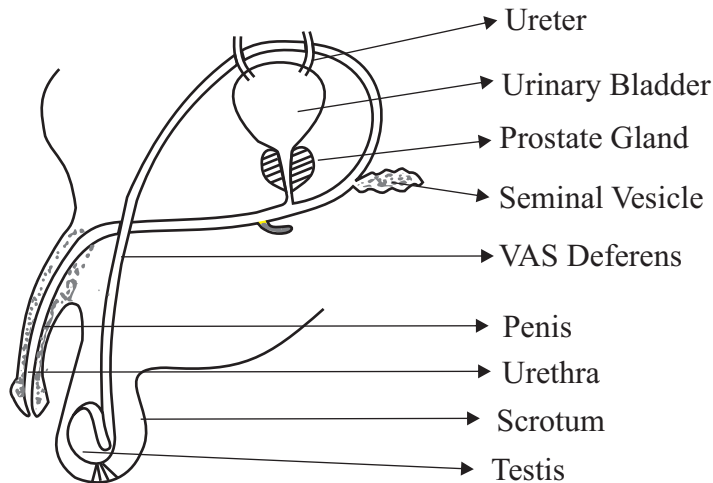

Human – male reproductive system

Female Reproductive System

(a) Ovary : A pair of ovary is located in both sides of abdomen.

- Female germ cells *i.e.*, eggs are produced here.
- At the time of birth of a girl, thousands of immature eggs are present in the ovary.
- At the onset of puberty, some of these eggs start maturing.
- One egg is produced every month by one of the ovaries.

(b) Oviduct or Fallopian tube

- Receives the egg produced by the ovary and transfer it to the uterus.
- Fertilisation *i.e.*, fusion of gametes takes place here.

(c) Uterus : It is a bag-like structure where development of the baby takes place after implantation of embryo in its wall.

- Uterus opens into vagina through cervix.

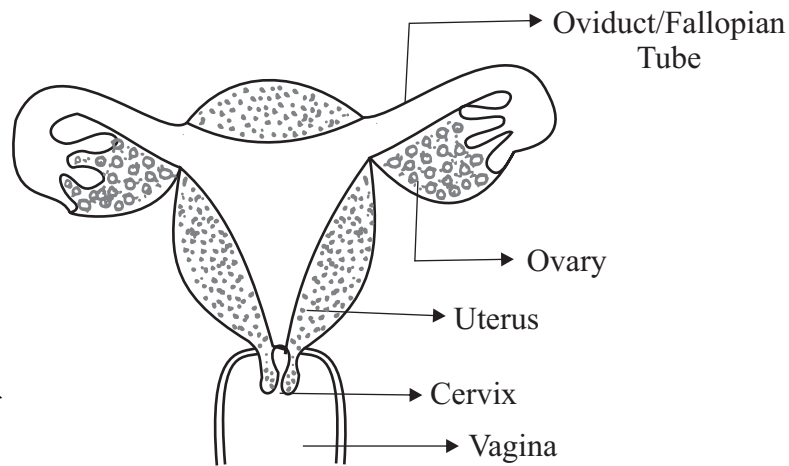

Human – female reproductive system

When egg is fertilised :

- The fertilized egg called zygote is planted in uterus and develops into an embryo.
- The embryo gets nutrition from the mother's blood with the help of a special tissue called placenta. It provides a large surface area for the exchange of glucose, oxygen and waste material.
- The time period from fertilization upto the birth of the baby is called gestation period. It is about 9 months.

When egg is not fertilised :

- The uterus prepares itself every month to receive fertilized egg.
- The lining of the uterus becomes thick and spongy, required to support the embryo.
- When fertilisation had not taken place, this lining is not needed any longer.
- This lining breaks and comes out through vagina as blood and mucus. This cycle takes around 28 days every month and called menstruation.

Reproductive Health

Reproductive health means a total well-being in all aspects of reproduction *i.e.*, physical, emotional, social and behavioural.

Sexually Transmitted Diseases (STDs)

- Many diseases can be sexually transmitted such as :
Bacterial : Gonorrhoea and syphilis
Viral : Warts and HIV-AIDS
- Use of condom prevents these infections to some extent.

Contraception

It is the avoidance of pregnancy, can be achieved by preventing the fertilisation of ova.

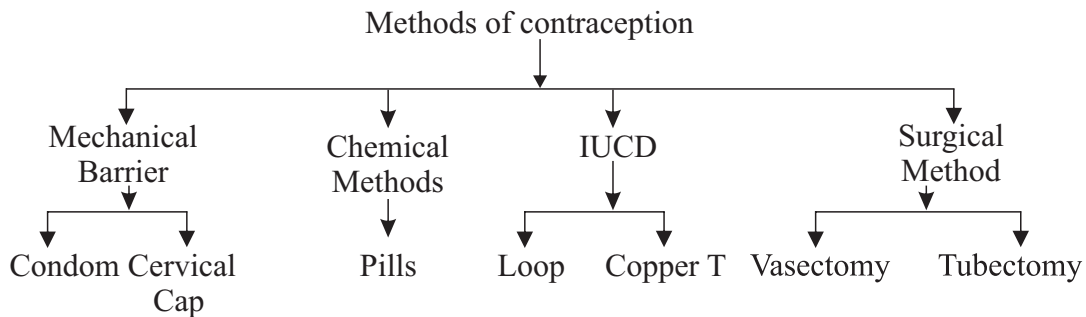

Methods of contraception

(a) Physical barrier

- To prevent union of egg and sperm.
- Use of condoms, cervical caps and diaphragm.

(b) Chemical methods

- Use of oral pills
- These change hormonal balance of body so that eggs are not released.
- May have side effects.

(c) Intrauterine contraceptive device (IUCD)

- Copper-T or loop is placed in uterus to prevent pregnancy.

(d) Surgical methods

- In males the vas deferens is blocked to prevent sperm transfer called vasectomy.
- In females, the fallopian tube is blocked to prevent egg transfer called tubectomy.

Female Foeticide

- The practice of killing a female child inside the womb is called female foeticide.
- For a healthy society, a balanced sex ratio is needed that can be achieved by educating people to avoid malpractices like female foeticide and prenatal sex determination.
- Prenatal sex determination is a legal offence in our country so as to maintain a balanced sex ratio.

MCQ Very Short Answer Type Questions (1 Marks)

- Q.1 Gametes are formed in-
- | | |
|---------------------------|------------------------|
| a) Asexual Reproduction | b) Sexual Reproduction |
| c) Vegetative Propagation | d) Tissue Culture |
- Q.2 Plasmodium reproduces by-
- | | |
|------------------|---------------------|
| a) Budding | b) Binary Fission |
| c) Fragmentation | d) Multiple fission |
- Q.3 Which of the following is not a part of flower.
- | | |
|-----------|-----------|
| a) Stem | b) Carpel |
| c) Stamen | d) Sepals |
- Q.4 Reproduction is essential for living organisms in order to
- | |
|---|
| a) Keep the individual organism alive |
| b) Fulfill their energy requirement |
| c) Maintain growth |
| d) Continue the species generation after generation |
- Q.5 Which among the following diseases is not sexually transmitted.
- | | |
|-------------|---------------|
| a) Syphilis | b) HIV-AIDS |
| c) Cholera | d) Gonorrhoea |
- Q.6 The ability of a cell to divide into two cells during reproduction in Leishmania is called.
- | | |
|-------------------|-----------------------|
| a) Budding | b) Reduction division |
| c) Binary fission | d) Multiple fission |
- Q.7 Characters transmitted from parents to off springs are present in
- | | |
|--------------|-----------------|
| a) Cytoplasm | (b) Ribosome |
| c) Genes | d) Golgi bodies |

Q. 8 In figure given here identify the parts A, B and C sequentially.

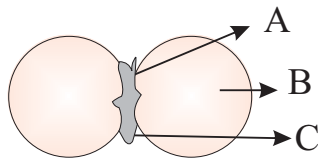

- a) Cotyledon, Plumule, Radicle b) Plumule, Radicle, Cotyledon
c) Plumule, Cotyledon, Radicle d) Radicle, Cotyledon, Plumule

Q.9 During adolescence several changes occur in the human body. Mark one change associated with sexual maturation in boys.

- a) Loss of milk teeth b) Increase in height
c) Weight gain d) Cracking of voice

Q.10 Which of the following is an example of unisexual flower

- a) Papaya b) Hibiscus
c) Mustard d) Petunia

Answer

1. (b) 2. (d) 3. (a) 4. (d) 5. (c) 6. (c)
7. (c) 8. (c) 9. (d) 10. (a)

11. Read the Assertion and reason carefully and select the correct answer to these question from the codes (a), (b), (c) and (d) as given below :

- (a) Both A and R are true, and R is correct explanation of the assertion
(b) Both A and R are true, but R is not the correct explanation of the assertion
(c) A is true but R is false
(d) A is false but R is true

1. Assertion : Testes in males are located outside the abdominal cavity in scrotum

Reason: Sperm formation requires a lower temperature than the normal body temperature

2. Assertion : The lining of uterus thickens and prepares itself every month to receive a fertilised egg.

Reason: The unfertilized egg implants itself to uterus wall for nutrition

3. Assertion : Conventionally the motile germ cell is male gamete

Reason: The germ cell with stored food is female gamete

4. Assertion : Hibiscus is a unisexual flower

Reason: A bisexual flower contains both male and female parts

5. Assertion : The human population size is a cause for concern

Reason: An expanding population makes it easier to improve living conditions

Answer:

- | | |
|--------|--------|
| 1. (a) | 2. (c) |
| 3. (b) | 4. (d) |
| 5. (c) | |

Read the following and answer the questions

The female reproductive system is made up of internal and external organs. The function of the system is formation of new offsprings. In humas the female reproductive system is immature at birth and develops to maturity at puberty to be able to produce gametes.

1. Which organ of female reproductive system acts as site of implantation of foetus
- (a) Ovary
 - (b) uterus
 - (c) Cervix
 - (d) Fallopain tube
2. Which of the statements is incorrect
- (a) When a girl is born the ovaries contain thousand of immature eggs
 - (b) The site of fertilization is uterus
 - (c) The menstrual cycle takes place roughly month
 - (d) If the egg is not fertilised it is discarded out with the uterus living
3. What is the life span of an unfertilized egg in human females
- (a) One week
 - (b) One month

- (c) One day
 - (d) 2–8 days
4. The disc like structure in uterine wall that provides foetus a surface for oxygen to pass is called
- (a) Cervix
 - (b) Ovary
 - (c) Placenta
 - (d) None of these
5. Identify the correct statement
- (a) The development of child inside mother's body takes approximately nine months
 - (b) The ovary releases two eggs per month
 - (c) The placenta contains villi on mother's side of the tissue
 - (d) The fertilized egg is called embryo and it divides to form zygote

Answer

1. (b) 2. (b) 3. (c)
4. (c) 5. (a)

VERY SHORT ANSWER TYPE QUESTIONS (1 Mark)

- 13. Name the two types of reproduction.
- 14. What type of reproduction takes place in Plasmodium ?
- 15. Define vegetative propagation.
- 16. Where is DNA present in a cell ?
- 17. Name the glands associated with male reproductive system.
- 18. What is menstruation ?
- 19. Name two contraceptive methods.
- 20. Where are the reproductive parts located in a plant ?

SHORT ANSWER TYPE QUESTIONS (3 Marks)

- 1. Write important functions of testosterone.
- 2. What is placenta ? Also write its functions. (CBSE-2018)
- 3. Why do we see different types of organisms around us ?
- 4. What is the importance of variation ? (CBSE-2018)

5. Why is vegetative propagation practised for growing some types of plants ?
6. Write names of male and female sex hormones.
7. Mention the parts of a flower.
8. Differentiate between bisexual and unisexual flowers.
9. What is tissue culture ?
10. Explain the process of fertilisation in flowering plants.
11. Name the different constituents of semen.
12. Draw a well-labelled diagram of male reproductive system.
13. What is pre-natal sex determination ? Why is it banned ?
14. Draw a labelled diagram of the longitudinal section of a flower.

LONG ANSWER TYPE QUESTIONS (5 Marks)

1. What are the different modes of asexual reproduction ?
2. Draw a labelled diagram of female reproductive system and write the function of its different parts. (CBSE-2018)
3. What is contraception ? Give different methods of contraception. (CBSE-2018)
4. What happens in human female :
 - (a) when egg is fertilised ?
 - (b) when egg is not fertilised ?
5. Trace and explain the steps involved in the formation of seed.
6. Define pollination. Explain the different types of pollination. List two agents of pollination? How does suitable pollination lead to fertilization? CBSE-2019

Hints to Long Answer Type Questions

1. Methods of asexual reproduction :
 - (a) Fission
 - (b) Fragmentation
 - (c) Regeneration
 - (d) Budding
 - (e) Vegetative propagation
 - (f) Spore formation
2. Labelled diagram of female reproductive system.

Functions :

Ovary : Production of eggs.

Oviduct : Site for fertilization.

Uterus : Place of development of embryo.

3. **Contraception** : Barrier for fertilisation.

- Physical barrier
- Chemical methods
- Surgical methods
- Intrauterine contraceptive device (IUCD)

4. (a) (i) Zygote is formed → Implanted in uterus

(ii) Onset of pregnancy

(b) Menstruation

5. Labelled diagram of germination of pollen grain on stigma of flower.

MCQs

1. Which of these statement is correct about reproduction?
 - (a) It keeps the individual organism alive
 - (b) It fulfills their energy requirement
 - (c) It maintains the growth
 - (d) It continues the species generation after generation
2. Which among the following is not the function of testes at puberty?

(a) Formation of germ cells	(b) Secretion of testosterone
(c) Development of placenta	(d) Secretion of estrogen
(a) (a) and (b)	(b) (b) and (c)
(c) (c) and (d)	(d) (d) and (a)
3. Length of pollen tube depends on the distance between
 - (a) Pollen grain and upper surface of stigma
 - (b) Pollen grain on upper surface of stigma and ovule
 - (c) Pollen grain in anther and upper surface of stigma
 - (d) Upper surface of stigma and lower part of style

4. A feature of reproduction that is common to Amoeba, Spirogyra and Yeast is that
- (a) They reproduce asexually
 - (b) They are all unicellular
 - (c) They reproduce only sexually
 - (d) They are all multicellular
5. Which of the following are examples of vegetative reproduction in plant?
- (a) Tomato, lady finger, onion and cauliflower
 - (b) Potato, ginger, onion and tomato
 - (c) Cauliflower, onion, potato and tomato
 - (d) Lady finger, onion, ginger and sugarcane
6. A student while observing an embryo of a gram seed listed various parts of the embryo as listed below. Testa, Micropyle, Cotyledon, Tegmen, Plumule, Radicle
- On examining the list the teacher commented that only 3 parts are correct. Select these three correct parts:
- (a) Cotyledon, Testa, Plumule
 - (b) Cotyledon, Plumule, Radicle
 - (c) Cotyledon, Tegmen, Radicle
 - (d) Cotyledon, Micropyle, Plumule
7. The correct sequence of reproductive stages in flowering plant is
- (a) Gametes, Zygote, embryo, seedling
 - (b) Zygote, gametes, embryo, seedling
 - (c) Seeding, embryo, zygote, gametes
 - (d) Gametes, embryo, zygote, seeding

8. Offspring formed by asexual method of reproduction have greater similarity among themselves because
- Asexual reproduction involves only one parent
 - Asexual reproduction does not involve gametes
 - Asexual reproduction occurs before sexual reproduction
 - Asexual reproduction occurs after sexual reproduction
- (1) (a) and (b) (2) (a) and (c)
 (3) (b) and (d) (4) (c) and (d)
9. The number of chromosomes in parents and offspring of a particular species remains constant due to
- Doubling of chromosomes after zygote formation
 - Halving of chromosomes during gametes formation
 - Doubling of chromosomes after gametes formation
 - Halving of chromosomes after gamete formation
10. In the list of organisms given below, those that reproduce by the asexual method are:
- Banana
 - Dog
 - Yeast
 - Amoeba
- (a) (ii) and (iv) (b) (i), (iii) and (iv)
 (c) (i) and (iv) (d) (ii), (iii) and (iv)

Answer

- (1) (d) (6) (b)
 (2) (c) (7) (a)
 (3) (b) (8) (l)
 (4) (a) (9) (b)
 (5) (b) (10) (b)



Chapter - 8

Heredity and Evolution

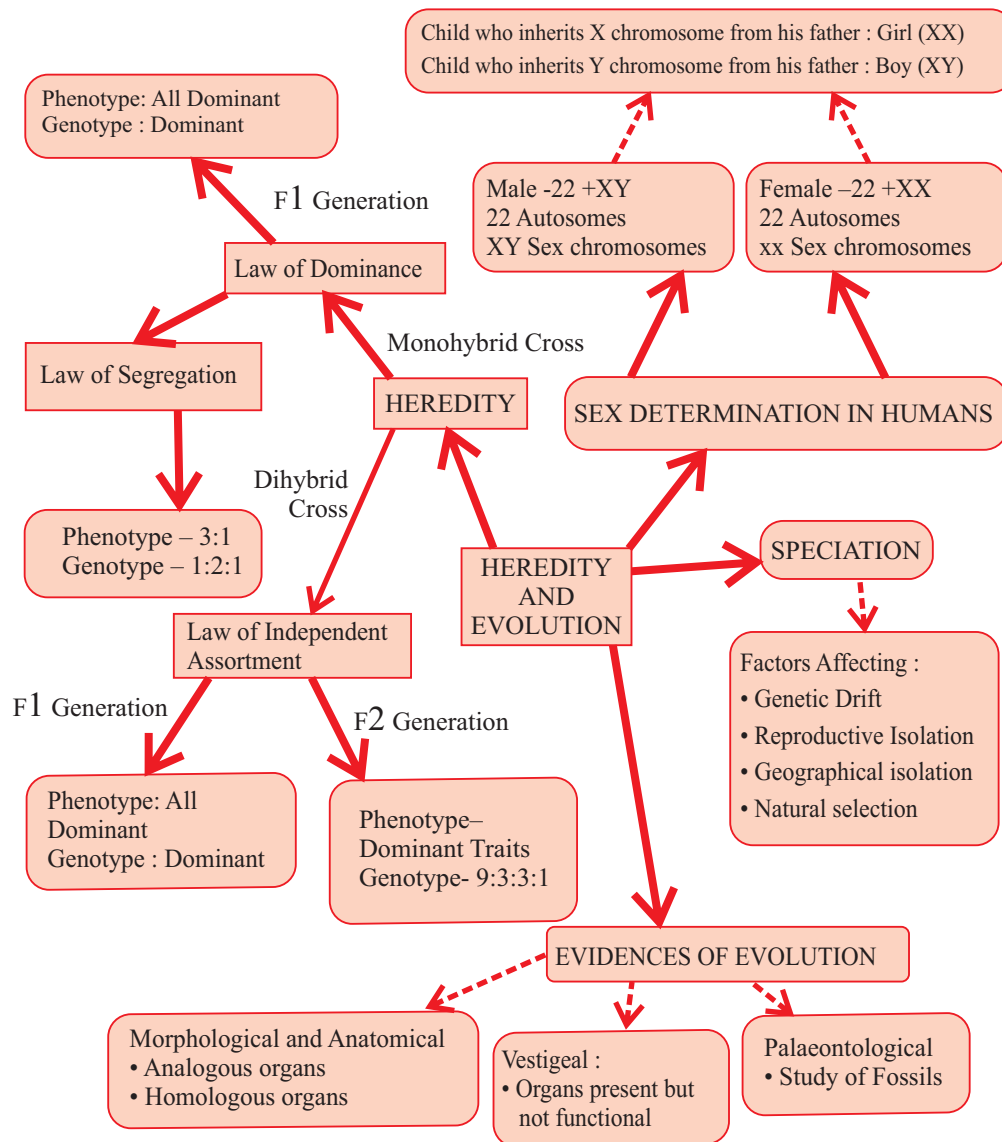

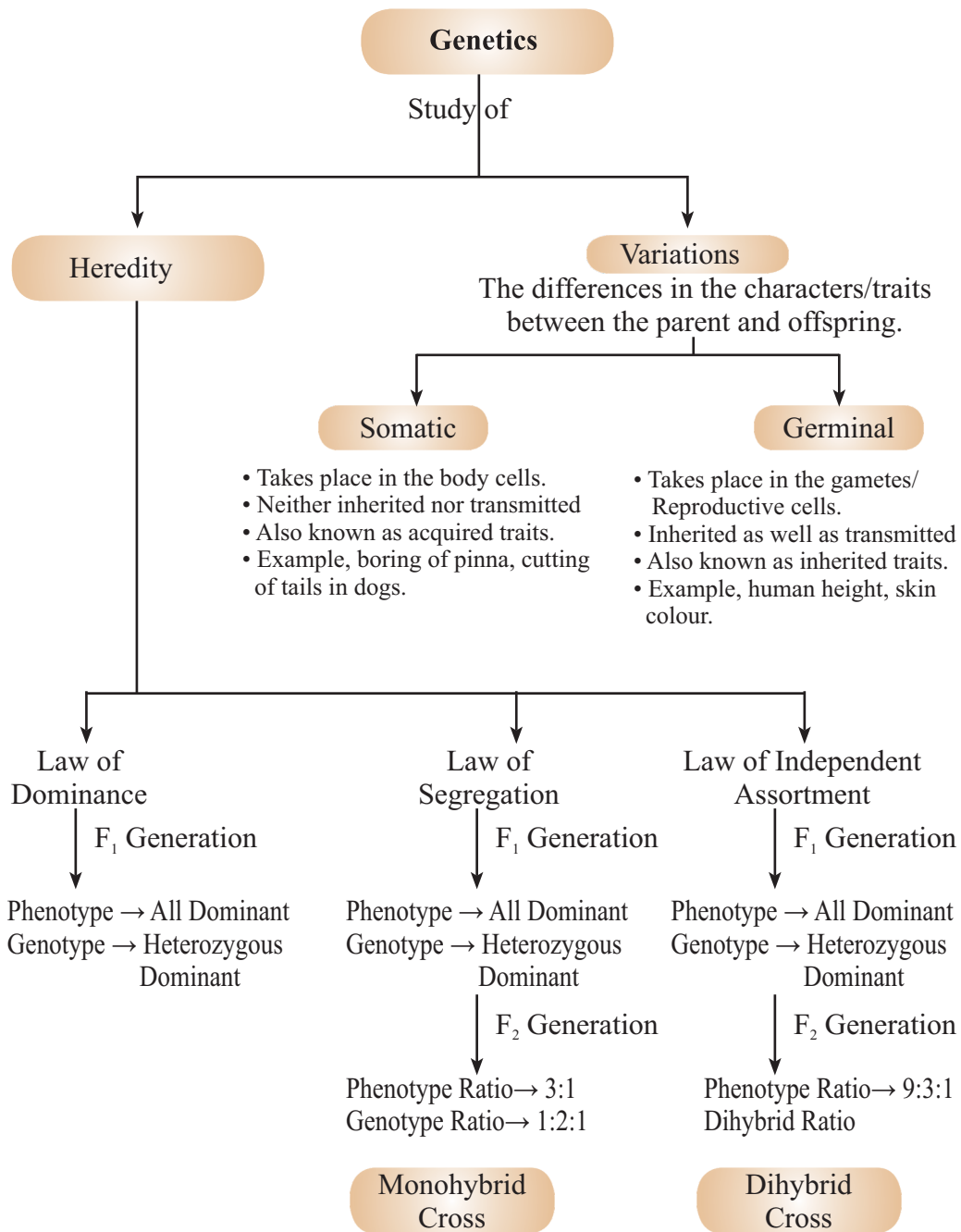

Accumulation of Variation during Reproduction

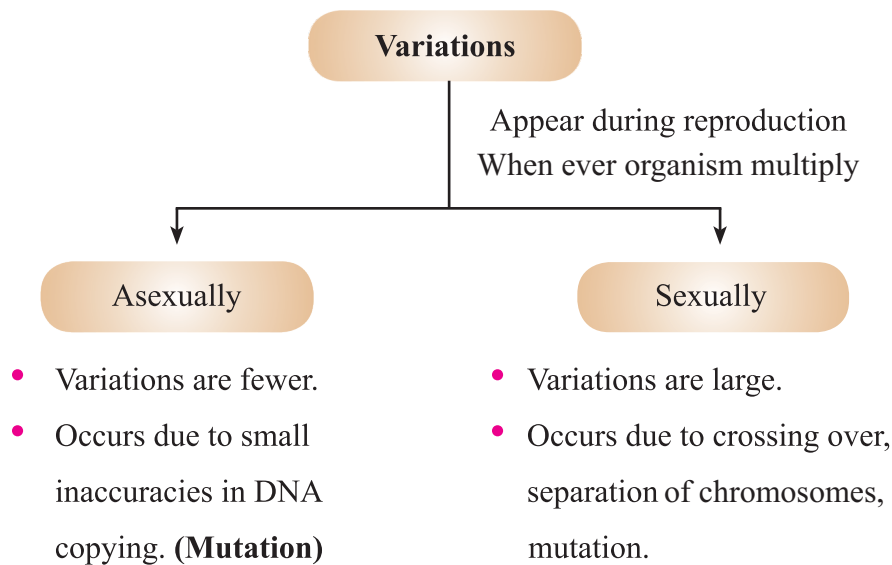















Importance of Variation :

- (i) Depending upon the nature of variations different individuals would have different kinds of advantage.
Example, Thermostatic Bacteria that can withstand heat will survive better in a heat wave.
- (ii) Main advantage of variation to species is that it increases the chances of its survival in a changing environment.

Free ear lobes and **attached ear lobes** are two variants found in human populations.

Mendel and His Work on Inheritance

- **Gregor Johann Mendel (1822 & 1884)** : Started his experiments on plant breeding and hybridisation. He proposed the laws of inheritance in living organisms.
Mendel was known as **Father of Genetics**.
- **Plant selected by Mendel** : *Pisum sativum* (garden pea). Mendel used a number of contrasting characters for garden pea.

CHARACTER	DOMINANT TRAIT	RECESSIVE TRAIT
Seed shape	 Round	 Wrinkled
Seed colour	 Yellow	 Green
Flower colour	 Violet	 White
Pod shape	 Inflated/full	 Constricted
Pod Colour	 Green	 Yellow
Flower position	 Axial	 Terminal
Stem height	 Tall	 Dwarf

Mendel's **Experimental Material** : He chose Garden Pea (*Pisum sativum*) as his experiment material because of :

- (i) Availability of detectable contrasting traits of several characters.
- (ii) Short life span of the plant.
- (iii) Normally allows self-fertilisation but cross-fertilisation can also be carried out.
- (iv) Large no. of seeds produced.

- **Mendel's Experiments** : Mendel conducted a series of experiments in which he crossed the pollinated plants to study one character (at a time).

Monohybrid Cross

Cross between two pea plants with one pair of contrasting characters is called a monohybrid cross.

Example : Cross between a tall and a dwarf plant (short).

TT] Both dominant traits]] Both recessive alleles]] Pure or homozygous condition
tt		
Tt] One dominant, one recessive trait]] Hetrozygous condition – Hybrid

Phenotypic ratio → 3 : 1

Genotypic ratio → 1 : 2 : 1

Phenotype → Physical appearance [Tall or Short]

Genotype → Genetic make up [TT, Tt or tt]

MONOHYBRID CROSS

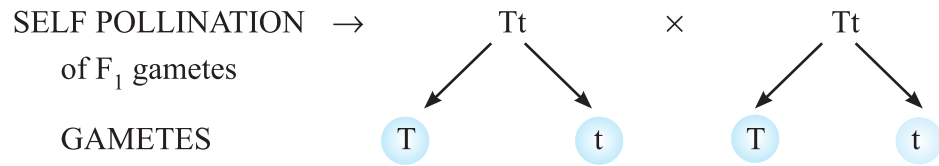
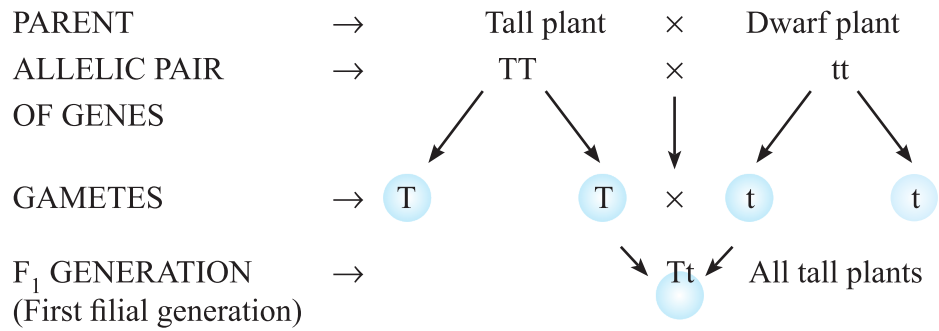

F₂ GENERATION →

Gametes →	T	t
T	TT tall	Tt tall
t	Tt tall	tt dwarf

Phenotypic ratio → 3 : 1 Tall : Dwarf

Genotypic ratio → 1 : 2 : 1 TT : Tt : tt

1 : 2 : 1

Observations of Monohybrid Cross

- All F₁ progeny were tall, no medium height plant. (Half way characteristic)
- F₂ progeny $\frac{1}{4}$ were short, $\frac{3}{4}$ were tall.
- Phenotypic ratio F₂ – 3 : 1 (3 tall : 1 short)

$$\text{Genotypic ratio F}_2 - 1 : 2 : 1 \left(\begin{array}{ccc} \text{TT} & : & \text{Tt} & : & \text{tt} \\ 1 & : & 2 & : & 1 \end{array} \right)$$

Conclusions

- TT and Tt both are tall plants while tt is a short plant.
- A single copy of T is enough to make the plant tall, while both copies have to be 't' for the plant to be short.
- Characters/traits like 'T' are called dominant trait (because it express itself) and 't' are recessive trait (because it remains suppressed).

Dihybrid Cross

A cross between two plants having two pairs of contrasting characters is called dihybrid cross.

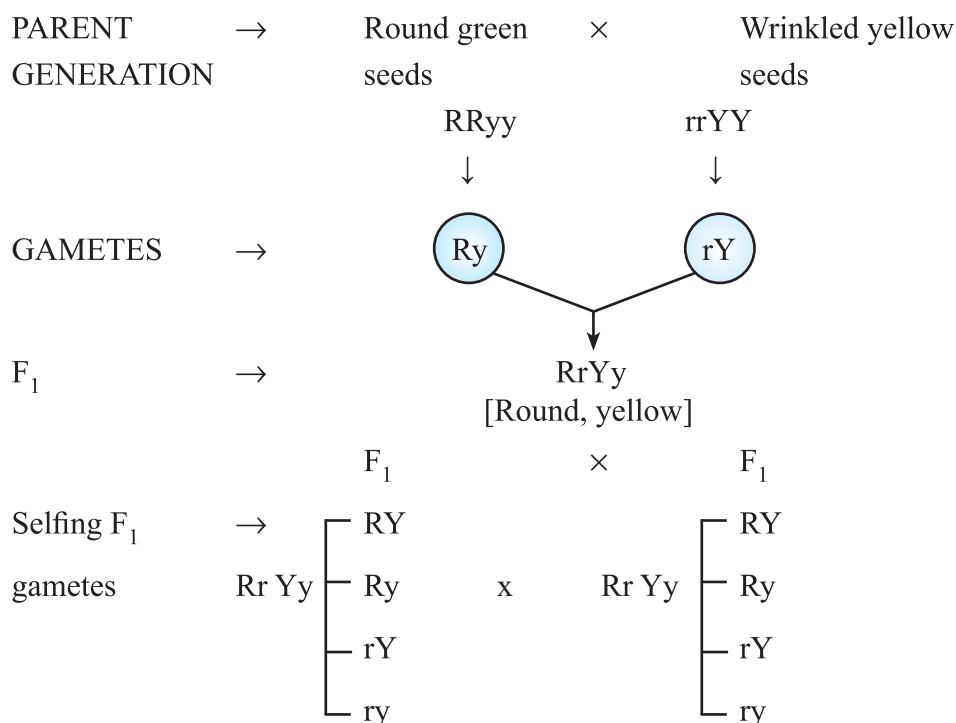

F₂ gametes →

	RY	Ry	rY	ry
RY	RRYY	RRYy	RrYY	RrYy
Ry	RRYy	RRyy	RrYy	Rryy
rY	RrYY	RrYy	rrYY	rrYy
ry	RrYy	Rryy	rrYy	rryy

Phenotypic Ratio

- Round, yellow : 9
- Round, green : 3
- Wrinkled, yellow : 3
- Wrinkled, green : 1

Observations

- (i) When RRyy was crossed with rrYY in F₁ generation all were Rr Yy round and yellow seeds.
- (ii) Self pollination of F₁ plants gave parental phenotype and two mixtures (recombinants round yellow and wrinkled green) seeds plants in the ratio of 9 : 3 : 3 : 1.

$$\begin{array}{cccc}
 9 & : & 3 & : & 3 & : & 1 \\
 \left(\begin{array}{c} \text{Round} \\ \text{yellow} \end{array} \right) & & \left(\begin{array}{c} \text{Round} \\ \text{green} \end{array} \right) & & \left(\begin{array}{c} \text{Wrinkled} \\ \text{yellow} \end{array} \right) & & \left(\begin{array}{c} \text{wrinkled} \\ \text{green} \end{array} \right)
 \end{array}$$

Conclusions

1. Round and yellow seeds are Dominant characters.
2. Occurrence of new phenotype combinations show that genes for round and yellow seeds are inherited independently of each other.

Mendel's Law of Inheritance

Based on his hybridisation experiments, Mendel proposed the laws of inheritance.

1. Law of dominance - This law states that when two alternative forms of a trait or character (genes or alleles) are present in an organism, only one factor expresses itself in F₁ progeny and is called dominant while the other that remains masked is called recessive.

Characters are controlled by discrete units called factors. Factors occur in pairs.

2. Law of segregation or law of purity of gametes.

This law states that the factors or alleles of a pair segregate from each other during gamete formation such that a gamete receives only one of the factors. They do not show any blending but simply remain together.

Homozygous parent produces all gametes that are similar, heterozygous parent produces two types of gametes, each having one allele in equal proportion.

3. Law of independent assortment - This law states that the two factors of each character assort or separate out independent of the factors of other characters at the time of gamete formation and get randomly rearranged in the offsprings producing both parental and new combination of characters.

When two pairs of traits are combined in a hybrid, segregation of one pair of character is independent of the other pair of characters.

How do these traits get expressed

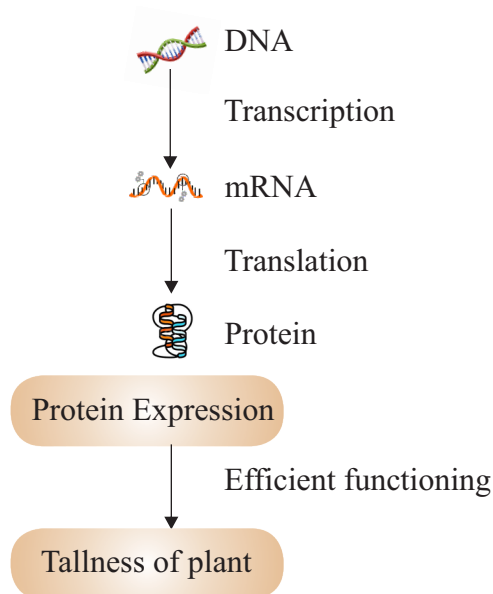

Genetic Control of Expression of Traits

SEX DETERMINATION

Determination of sex of an offspring.

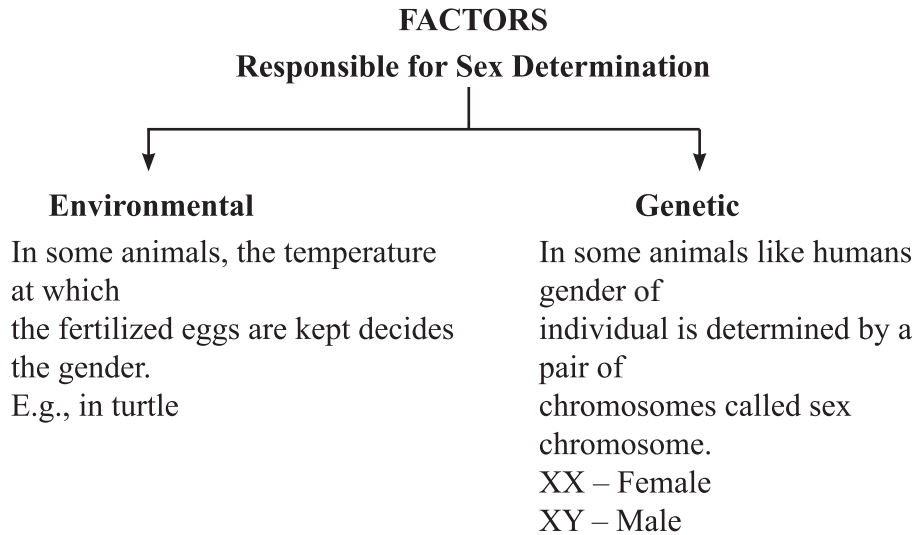

Sex Chromosomes : In human beings, there are 23 pairs of chromosome. Out of these 22 chromosomes pairs are called autosomes and the last pair of chromosome that help in deciding gender of that individual is called sex chromosome.

XX – Female SEX
XY – Male CHROMOSOMES

Sex determination in Human Beings

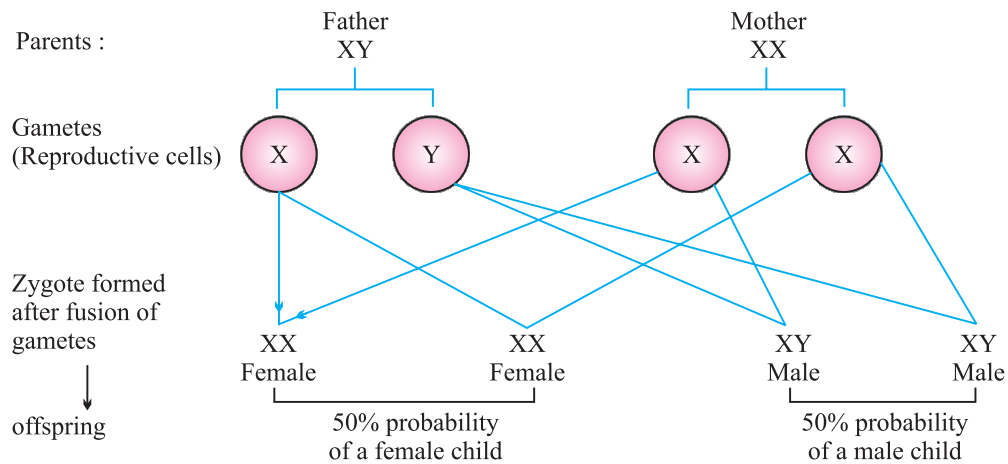

This shows that half the children will be boys and half will be girls. All children will inherit an X chromosome from their mother regardless whether they are boys or girls. Thus, sex of children will be determined by what they inherit from their father, and not from their mother.

Blood Group Inheritance In Human Beings:-

There are four blood groups in human beings namely A, B, AB and O and their expression in human population is controlled by three alleles namely I^A , I^B and i [Multiple Allelism]. An individual has only two alleles out of three for blood group. Genotypes and Phenotypes for these 4 blood groups are as under-

PHENOTYPE/ Blood Group	PROBABLE GENOTYPE
A	$I^A I^A ; I^A i$
B	$I^B I^B ; I^B i$
AB	$I^A I^B$
O	ii

There Are 6 probable genotypes for 4 phenotypes.

1. Assertion (A) : Mendel chose a pea plant for his experiments.
Reason (R) : Pea is easy to grow and had distinctly easily detectable contrasting variants of features.
2. Assertion (A) : Variation is minimum in asexual reproduction.
Reason (R) : All variations in a species have equal chance of survival.
3. Assertion (A) : Recessive trait can only be expressed in homozygous condition.
Reason (R) : Dominant trait cannot be expressed in heterozygous condition.

Answer:

1. (a) 2. (c) 3. (c)

Very Short Answer Type Questions (1 Marks)

4. (1) Write the scientific name of garden pea and human being.
(2) Where are genes located
(3) No two individuals are absolutely alike in a population. Why?
(4) What are the chromosomes XY and XX known as?
5. Give Reasons :
(1) Mendel chose pea plant for his experiments
(2) Human beings who look different from each other in terms of size, colour and looks are said to belong to same species.

Short Answer Type Question

1. Variation is beneficial to the species but not necessarily for the individual. Give three reasons to justify it.
2. Distinguish between autosomes and sex chromosomes.
3. A cross is carried between pure bred tall plant and pure bred dwarf pea plant.
(a) What is the phenotype of F_1 progeny and why
(b) What is the phenotype of F_2 progeny when F_1 is selfed.

2 Marks

1. Explain sex determination.
2. What are genes? Where are they located?
3. What is meant by dominant genes and recessive genes? Give one example of each.
4. What are sex chromosomes?
5. How many sex chromosomes are there? Name them.
6. Write down the phenotypic ratio and genotypic ratio in monohybrid cross.

Long Answer Type of Questions (5 Marks)

1. Explain few mechanism of sex determination in human being.
2. (a) What are dominant and recessive traits?
(b) Is it possible that a trait is inherited but may not be expressed in the next generation? Give a suitable example to justify this statement.

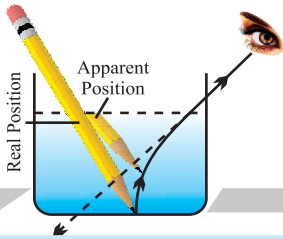

Chapter - 9

Light

- Light is the form of energy that enables us to see.

Properties of Light

- Electromagnetic wave, so does not require any medium to travel.
- Light tends to travel in straight line.
- Light has dual nature *i.e.*, wave as well as particle.
- Light casts shadow.
- Speed of light is maximum in vacuum. Its value is $3 \times 10^8 \text{ ms}^{-1}$.
- When light falls on a surface, following may happen :
 - (a) Reflection
 - (b) Refraction
 - (c) Absorption

REFLECTION

Bouncing back of light when it strikes on a polished surface like mirror.

Laws of Reflection :

- (1) Angle of incidence is equal to the angle of reflection.
- (2) The incident ray, the reflected ray and the normal at the point of incidence, all lie in the same plane.

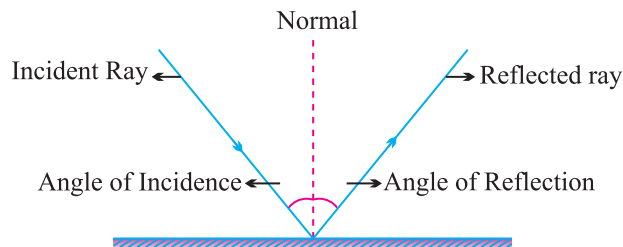
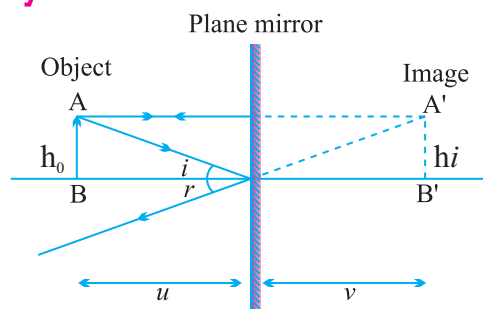

Image : It is a point where atleast two light rays actually meet or appear to meet.

Real Image	Virtual Image
<ul style="list-style-type: none"> • Formed when light rays actually meet. • Can be obtained on screen. • Inverted • <i>E.g.</i>, image formed on cinema screen. 	<ul style="list-style-type: none"> • Formed when light rays appear to meet. • Can't be obtained on screen. • Erect • <i>E.g.</i>, image formed by plane mirror or convex mirror.

Image Formed by Plane Mirror



Characteristics of Image

- Virtual and erect.
- Size of image is equal to the size of object.
- Image is formed as far behind the mirror as the object is in front of it.
- Laterally inverted.

Lateral Inversion : The right side of the object appears left side of the image and vice-versa.

Application of lateral inversion : The word AMBULANCE is written as ENAJUƆBMA so that it can be read correctly in rear view mirror of vehicles going in front of it.

Spherical Mirrors : Mirrors whose reflecting surface is curved.

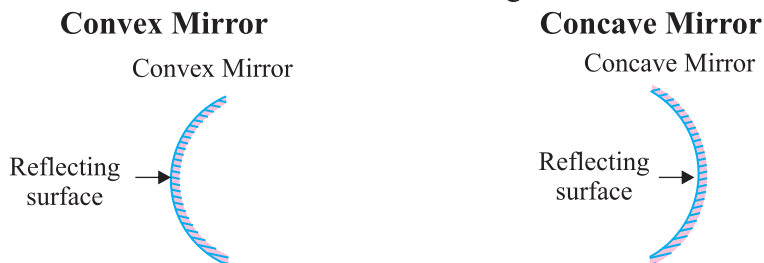

- Reflecting surface is curved outwards.
- Diverging mirror
- Reflecting surface is curved inwards.
- Converging mirror

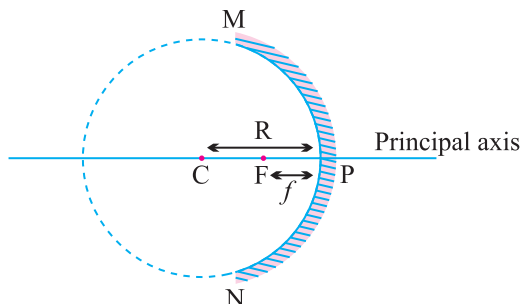

- **Principal axis** : The line joining the pole and center of curvature.
- **Pole (P)** : The centre of the spherical mirror.
- **Aperture (MN)** : It is the effective diameter of the spherical mirror.
- **Center of Curvature (C)** : The centre of the hollow glass sphere of which the mirror was a part.
- **Radius of Curvature (R)** : The distance between the pole and the centre of curvature (PC).
- **Focus (F)** : The point on principal axis where all the parallel light rays actually meet or appear to meet after reflection.
- **Focal length (f)** : The distance between the pole and the focus (PF).

Relationship between focal length and radius of curvature :

$$f = \frac{R}{2}$$

Important Variables \rightarrow u, v, R, f, h_o , h_i , m

Rules for making ray diagrams by concave mirror

- (i) A ray parallel to the principal axis will pass through the principal focus, after reflection.

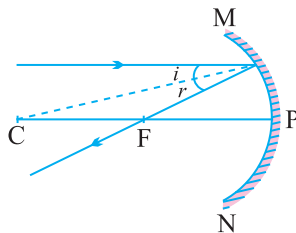

- (ii) A ray passing through the principal focus of concave mirror will emerge parallel to principal axis after reflection.

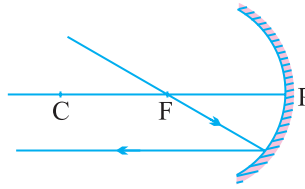

- (iii) A ray of light passing through the centre of curvature of a concave mirror is reflected back along the same path as it is a normally incident ray.

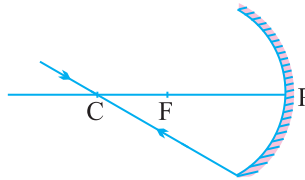

- (iv) A ray incident obliquely to the principal axis of a concave mirror is reflected obliquely making equal angle.

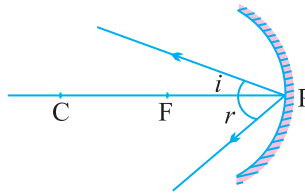

Ray diagrams for images formed by concave mirror

- (i) When object is at infinity :

Parallel rays from object at infinity

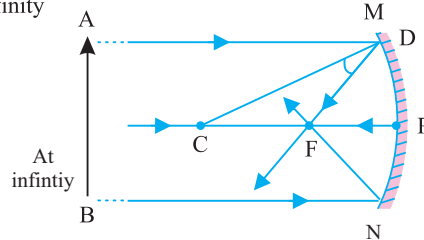

Image

Position – At 'F'

Nature – Real, inverted

Size – Point sized or highly diminished

- (ii) When object is beyond 'C'

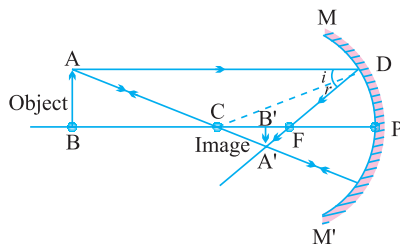

Image

Position – Between 'F' and 'C'

Nature – Real, inverted

Size – Diminished

(iii) When object is at 'C'

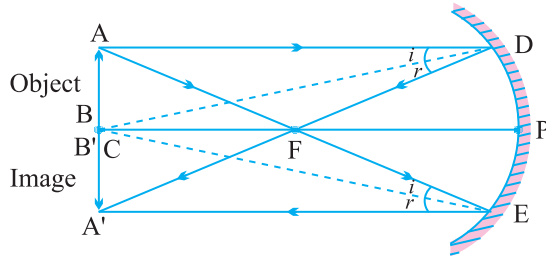

Image

Position – At 'C'

Nature – Real, inverted

Size – Same size as that of object

(iv) When object is placed between 'F' and 'C' **Image**

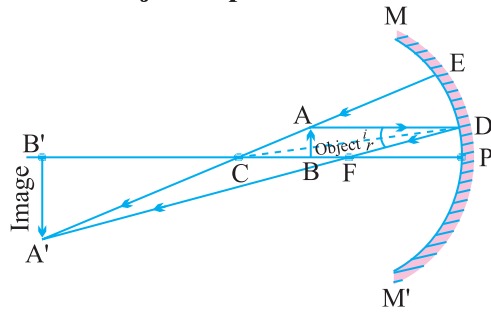

Position – Beyond 'C'

Nature – Real, inverted

Size – Enlarged

(v) When object is placed at 'F'

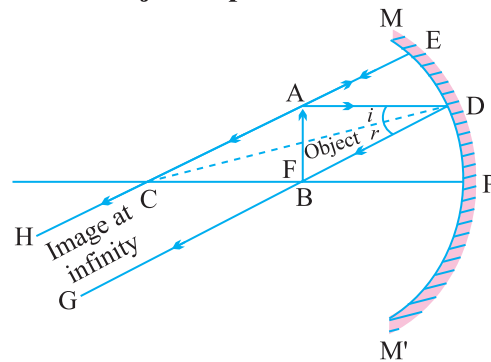

Image

Position – At Infinity

Nature – Real, inverted

Size – Highly enlarged

(vi) When object is between 'P' and 'F' **Image**

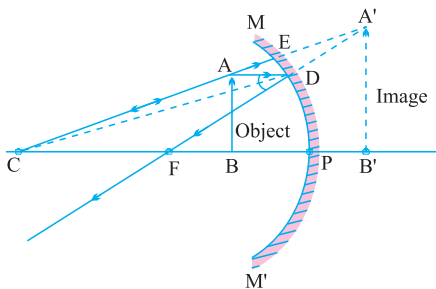

Image

Position – Behind the mirror

Nature – Virtual, erect

Size – Enlarged

Uses of Concave Mirror

- (i) Used in torches, search lights and vehicles headlights to get powerful parallel beam of light.

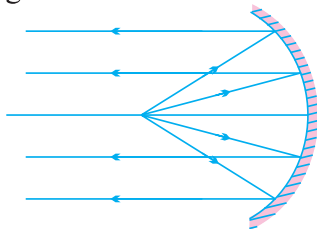

- (ii) Concave mirrors are used by dentists to see large image of teeth of patients. (Teeth have to be placed between pole and focus).

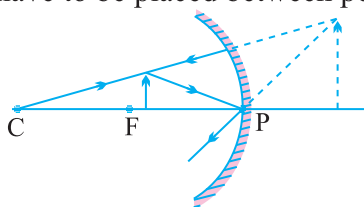

- (iii) Concave mirror is used as shaving mirror to see a larger image of the face.
(iv) Large concave mirrors are used to concentrate sunlight to produce heat in solar furnace.

Rule for image formation by Convex Mirror

- (i) A ray of light parallel to the principal axis of a convex mirror appear to diverge from the principal focus.

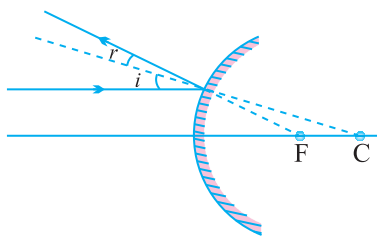

- (ii) A ray which is directed towards the focus of the convex mirror will emerge parallel to the principal axis after reflection.

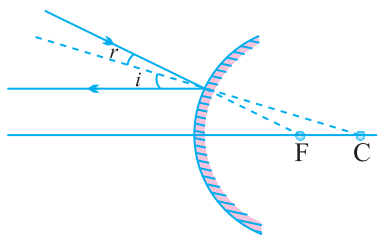

- (iii) A ray directed towards the center of curvature of a convex mirror is reflected back along the same.

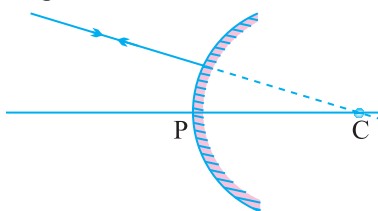

- (iv) A ray incident obliquely to the principal axis is reflected obliquely.

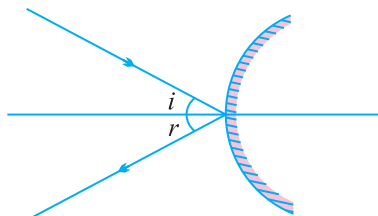

Ray diagrams of images formed by convex mirror

- (i) When object is placed at infinity : **Image**

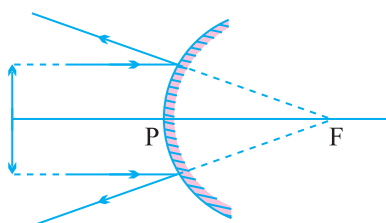

Position – At 'F'
Nature – Virtual, erect
Size – Point sized

- (ii) When object is placed between pole and infinity: **Image**

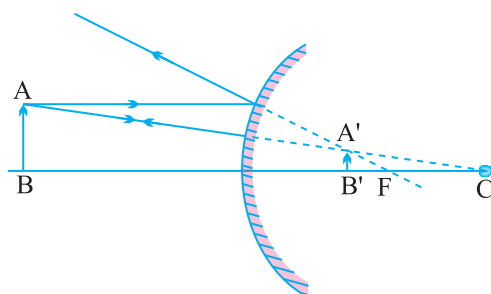

Position – Between 'P' and 'F'
Nature – Virtual, erect
Size – Diminished

- A full length image of a tall building/tree can be seen in a small convex mirror.

Uses of Convex Mirror

- (i) Convex mirrors are used as rear view mirrors in vehicles because

- (a) they always give an erect though diminished image.
- (b) they have a wider field of view as they are curved outwards.

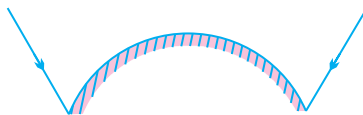

- (ii) Convex mirrors are used at blind turns and on points of merging traffic to facilitate vision of both side traffic.
- (iii) Used in shops as security mirror.

Sign Convention for Reflection by Spherical Mirror

Or

New Cartesian Sign Convention

- (i) The object is placed to the left of the mirror.
- (ii) All distances parallel to the principal axis are measured from the pole of the mirror.
- (iii) All distances measured in the direction of incident ray (along + X-axis) are taken as positive and those measured against the direction of incident ray (along – X-axis) are taken as negative.
- (iv) Distance measured perpendicular to and above the principal axis are taken as positive.
- (v) Distances measured perpendicular to and below the principal axis are taken as negative.

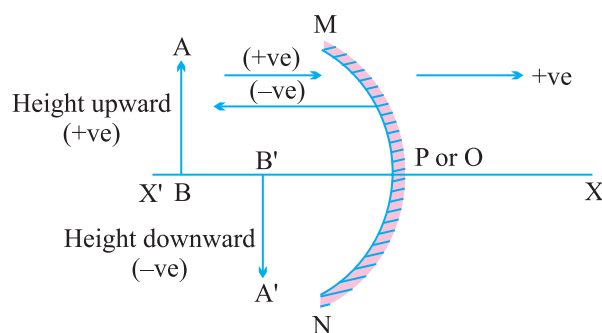

- Object distance = ' u ' is always negative.
- Focal length of concave mirror = Negative ($f = -ve$)
- Focal length of convex mirror = Positive ($f = +ve$)

	Concave Mirror						Convex Mirror	
	(i)	(ii)	(iii)	(iv)	(v)	(vi)	(i)	(ii)
u	-	-	-	-	-	-	-	-
v	-	-	-	-	-	+	+	+
R	-	-	-	-	-	-	+	+
f	-	-	-	-	-	-	+	+
h_o	+	+	+	+	+	+	+	+
h_i	-	-	-	-	-	+	+	+
m	-	-	-	-	-	+	+	+

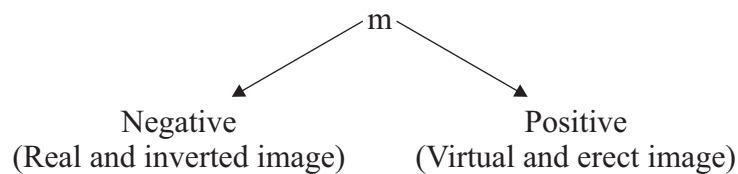

Mirror Formula :

$$\frac{1}{v} + \frac{1}{u} = \frac{1}{f}$$

where, v = Image distance

u = Object distance

f = Focal length

Magnification of Spherical Mirrors (m)

It is the ratio of the height of image to the height of object.

$$m = \frac{\text{Height of image}}{\text{Height of object}}$$

$$m = \frac{h_i}{h_o}$$

Also,

$$m = \frac{\text{image distance}}{\text{object distance}}$$

$$m = -\frac{v}{u}$$

If $h_i = h_o$ then $m = 1$, *i.e.*, image is equal to object.

If $h_i > h_o$ then $m > 1$ *i.e.*, image is enlarged.

If $h_i < h_o$ then $m < 1$ *i.e.*, image is diminished.

- Magnification of plane mirror is always + 1.
‘+’ sign indicates virtual image.
‘1’ indicates that image is equal to object’s size.
- If ‘ m ’ is ‘+ve’ and less than 1, it is a convex mirror.
- If ‘ m ’ is ‘+ve’ and more than 1, it is a concave mirror.
- If ‘ m ’ is ‘.ve’, it is a concave mirror.

Check Your Knowledge

1. Magnification of plane mirror is + 1. What does it indicate ?
2. A real image, $\frac{1}{5}$ th size of object is formed at a distance of 18 cm from a mirror. What is the nature of the mirror ? Calculate its focal length.
3. Name the type of mirror used in the following and reason for using it :
 - (a) Solar furnace
 - (b) Rear view mirror in a vehicle
4. What should be the position of the object, when a concave mirror is used :
 - (a) as a shaving mirror ?
 - (b) in torches as reflecting mirror ?
5.
 - (a) Define principal focus of a spherical mirror.
 - (b) For what position of the object does a concave mirror form a real, inverted and diminished image of the object ? Draw the ray diagram.
 - (c) An object 4 cm high is placed at a distance of 6 cm in front of a concave mirror of focal length 12 cm. Find the position of the image.
6. For what position of an object, a concave mirror forms a real image equal to size of object ?
7. Identify the nature of mirror and mention two characteristics of image formed when magnification $m = + 6$.
8. Suggest a method to find approximate focal length of a concave mirror.

9. Draw ray diagram when :
- (a) object is placed between pole and focus of a concave mirror.
 - (b) object is placed at infinity from a convex mirror.
10. Name the type of spherical mirror which
- (a) has positive focal length.
 - (b) always forms a virtual image.

REFRACTION

Bending of light when it enters obliquely from one transparent medium to another.

- Speed of light is maximum in vacuum. It is 3×10^8 m/s.
- **Cause of refraction :** Change in speed of light.
- **Some examples of refraction :**
 - (i) The bottom of swimming pool appears higher.
 - (ii) A pencil partially immersed in water appears to be bent at the interface of water and air.

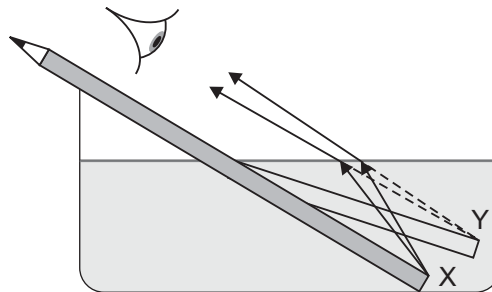

- (iii) Lemons placed in a glass tumbler appear bigger.
- (iv) Letters of a book appear to be raised when seen through a glass slab.

Refraction through glass slab

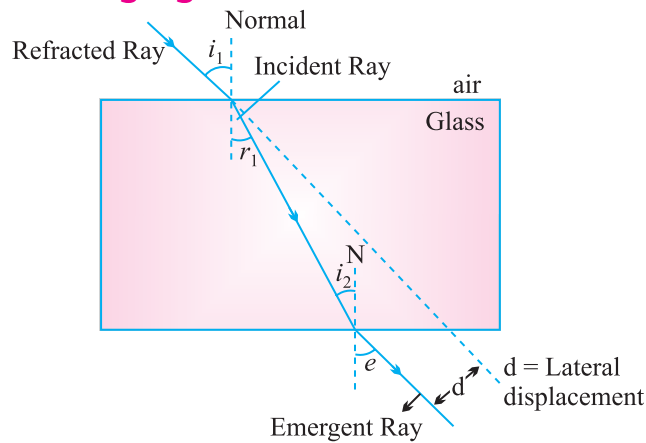

- The extent of bending of ray of light at the opposite parallel faces of rectangular glass slab is equal and opposite, so the ray emerges parallel to incident ray. The perpendicular distance between incident and emergent rays is called lateral displacement.
- Lateral displacement depends on :
 - (a) Refractive index of glass slab
 - (b) Thickness of the glass slab
 - (c) Wavelength of light rays
 - (d) Angle of incidence

Laws of Refraction

- (i) The incident ray, the refracted ray and the normal to the interface of two transparent media at the point of incidence, all lie in the same plane.
- (ii) **Snell's law** : The ratio of sine of angle of incidence to the sine of angle of refraction is a constant, for a light of given colour and for a given pair of media.

$$\frac{\sin i}{\sin r} = \text{constant}$$

Refractive index (n) : The ratio of speed of light in a given pair of media

$$n = \frac{\text{Velocity of light in medium 1}}{\text{Velocity of light in medium 2}}$$

n_{21} means refractive index of second medium with respect to first medium, and

$$n_{21} = \frac{v_1}{v_2}$$

n_{12} means refractive index of first medium with respect to second medium.

$$n_{12} = \frac{v_2}{v_1}$$

- **Absolute Refractive Index** : Refractive index of a medium with respect to vacuum or air.

$$n = \frac{c}{v} \quad (c = 3 \times 10^8 \text{ ms}^{-1})$$

- Refractive index of one medium is reciprocal of other's refractive index in a given pair.

$$n_{12} = \frac{1}{n_{21}}$$

If refractive index of medium 1 w.r.t. air is given as ${}_1n^{\text{air}}$, and

If refractive index of medium 2 w.r.t. air is given as ${}_2n^{\text{air}}$

Then, refractive index of medium 1 w.r.t. medium 2 = $\frac{{}_1n^{\text{air}}}{{}_2n^{\text{air}}}$

- Refractive index of diamond is the highest till date. It is 2.42. It means speed of light is $\frac{1}{2.42}$ times in diamond of that in vacuum.
- **Optically denser medium** : Out of two given media, the medium with higher value of refractive index.

- **Optically rarer medium** : Out of two given media, the medium with lower value of refractive index.
- When light enters obliquely from a rarer to a denser medium, it bends towards the normal.

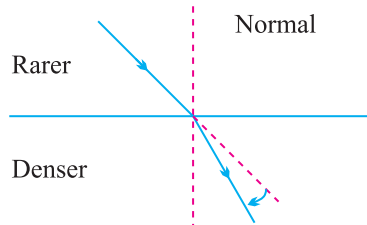

- When light enters obliquely from denser to a rarer medium, it bends away from the normal.

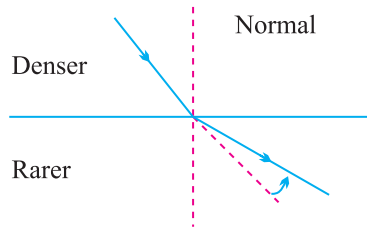

- Refractive index of a medium does not depend on physical density.

Spherical lens : A transparent medium bound by two surfaces, of which one or both surfaces are curved.

Spherical lens	
Convex lens	Concave lens
<ul style="list-style-type: none"> • Thin from corners • Thick at center • Converging 	<ul style="list-style-type: none"> • Thick from corners • Thin at centre • Diverging



Plano convex

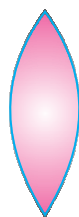

Biconvex



Plano concave

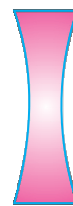

Biconcave

Rules for image formation by convex lens

- (i) A ray of light parallel to principal axis of a convex lens always pass through the focus on the other side of the lens.

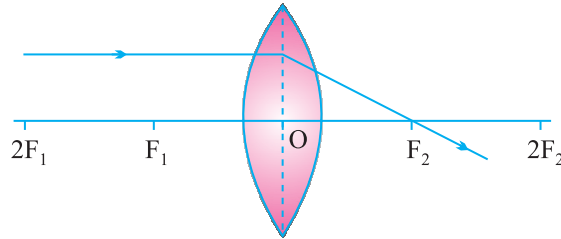

- (ii) A ray of light passing through the principal focus will emerge parallel to principal axis after refraction.

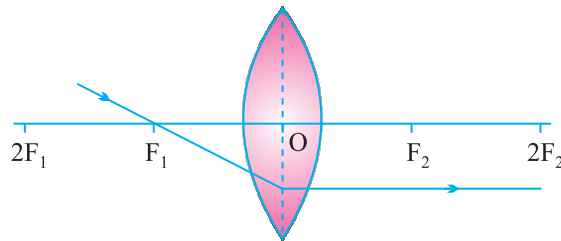

- (iii) A ray of light passing through the optical center will emerge without any deviation.

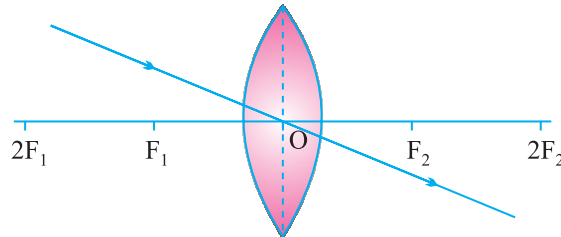

Ray Diagrams of Imaged formed by Convex Lens

- (i) When object is at infinity :

Image

Position – At ' F_2 '

Nature – Real, inverted

Size – Point sized or highly diminished

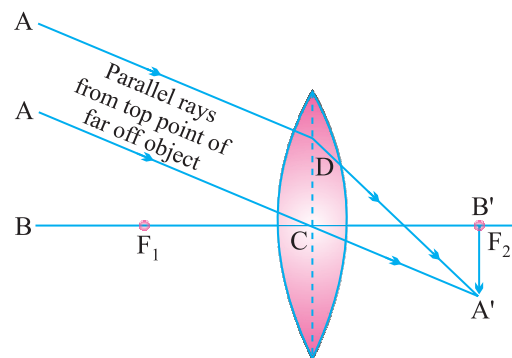

(ii) When object is beyond ' $2F_1$ '

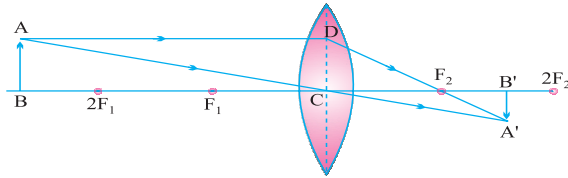

Image

Position – Between ' F_2 ' and ' $2F_2$ '

Nature – Real, inverted

Size – Diminished

(iii) When object is at ' $2F_1$ '

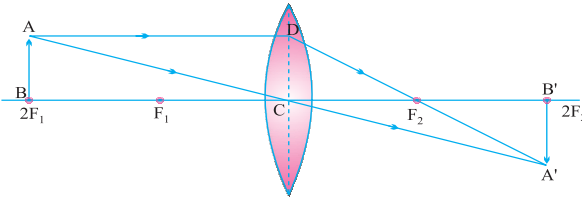

Image

Position – At ' $2F_2$ '

Nature – Real, inverted

Size – Same size

(iv) When object is between ' F_1 ' and ' $2F_1$ '

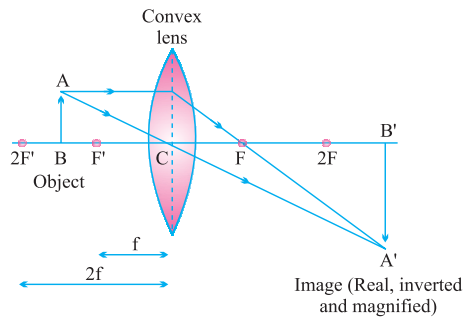

Image

Position – Beyond ' $2F_2$ '

Nature – Real, inverted

Size – Enlarged

(v) When object is at ' F_1 '

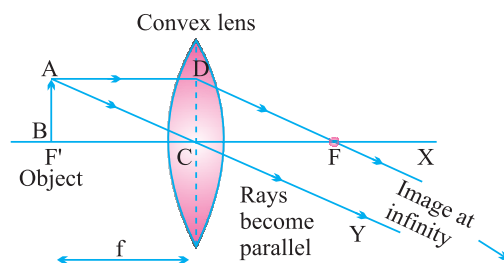

Image

Position – At Infinity

Nature – Real, inverted

Size – Highly enlarged

(vi) When object is between ' F_1 ' and optical centre

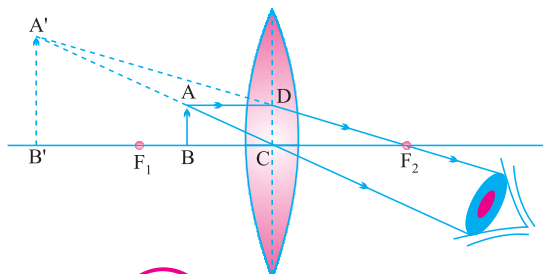

Image

Position – On the same side of the lens as object

Nature – Virtual and erect

Size – Enlarged

On the basis of this position, this lens is also known as magnifying lens.

Rules for Image Formation by Concave Lens

S.No.	Light ray from object is	Ray diagram	How it appears after refraction
1.	Parallel to the principal axis		After refraction from a concave lens, the ray appears to diverge from the principal focus located on the same side of the lens
2.	Passing through a principal focus		After refraction from a concave lens, the ray appears to diverge from the principal focus located on the same side of the lens
3.	Passing through the optical center of a lens		After refraction from a concave lens will emerge without any deviation

Ray Diagrams of Images Formed by a Concave Lens

(i) When object is placed at infinity : Image

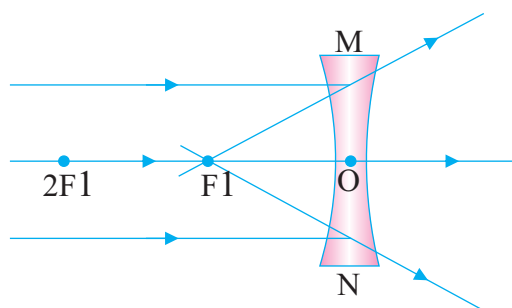

Position – At ' F_1 '

Nature – Virtual, erect

Size – Point sized or highly diminished

(ii) When object is placed between infinity and optical centre

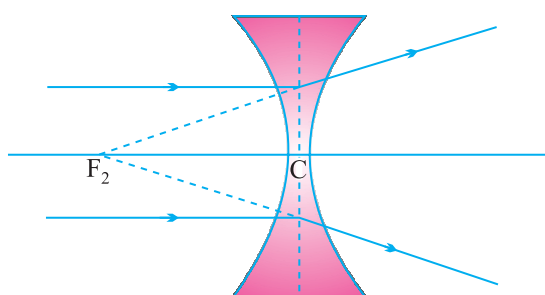

Position – Between ‘F’ and ‘O’

Nature – Virtual, erect

Size – Diminished

Sign convention for spherical lenses

- Sign conventions are similar to the one used for spherical mirrors, except that measurements are taken from optical center of the lens.
- Focal length of convex lens = Positive
Focal length of concave lens = Negative

Lens Formula :

$$\frac{1}{v} - \frac{1}{u} = \frac{1}{f}$$

Magnification :

$$m = \frac{h_i}{h_o}$$

∴ h_i = height of image
 h_o = height of object

Also,

$$m = \frac{v}{u}$$

	Convex Lens						Concave Lens	
	(i)	(ii)	(iii)	(iv)	(v)	(vi)	(i)	(ii)
u	-	-	-	-	-	-	-	-
v	+	+	+	+	+	-	-	-
f	+	+	+	+	+	+	-	-
h_o	+	+	+	+	+	+	+	+
h_i	-	-	-	-	-	+	+	+
m	-	-	-	-	-	+	+	+

Power of a lens :

It is defined as the reciprocal of focal length in meter.

The degree of convergence or divergence of light rays is expressed in terms of power.

$$\text{Power} = \frac{1}{\text{focal length (in meter)}} \quad P = \frac{1}{f}$$

- SI unit of Power = dioptre = D

$$1 \text{ D} = 1 \text{ m}^{-1}$$

1 dioptre is the power of lens whose focal length is one meter.

- Power of convex lens = Positive
- Power of concave lens = Negative

- $\text{Power} \propto \frac{1}{\text{focal length}}$

- Power of a lens combination

$$P = P_1 + P_2 + P_3 \dots\dots\dots$$

1 MARKER OBJECTIVE QUESTIONS

I. MULTIPLE CHOICE QUESTIONS

1. Focal length of plane mirror is
 - a) At infinity
 - b) Zero
 - c) Negative
 - d) None of these
2. Image formed by plane mirror is
 - a) Real and erect
 - b) Real and inverted
 - c) Virtual and erect
 - d) Virtual and inverted
3. A concave mirror gives real, inverted and same size image if the object is placed
 - a) At F
 - b) At infinity
 - c) At C
 - d) Beyond C
4. Power of the lens is -40, its focal length is
 - a) 4m
 - b) -40m
 - c) -0.25m
 - d) 25 m

13. Study the given ray diagrams and select the correct statement from the following:

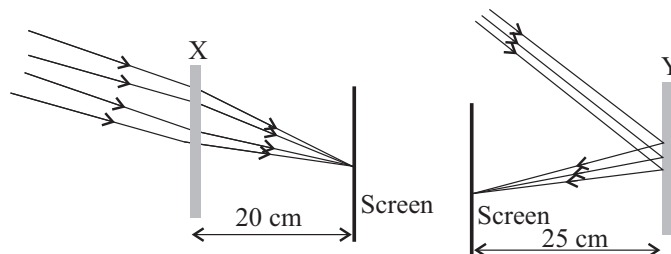

- (A) Device X is a concave mirror and device Y is a convex lens, whose focal lengths are 20 cm and 25 cm respectively.
- (B) Device X is a convex lens and device Y is a concave mirror, whose focal lengths are 10 cm and 25 cm respectively.
- (C) Device X is a concave lens and device Y is a convex mirror, whose focal lengths are 20 cm and 25 cm respectively.
- (D) Device X is a convex lens and device Y is a concave mirror, whose focal lengths are 20 cm and 25 cm respectively. (CBSE 2017)
14. A student obtains a blurred image of distant object on a screen using a convex lens. To obtain a distinct image on the screen he should move the lens.
- (A) away from the screen
- (B) towards the screen
- (C) to a position very far away from the screen
- (D) either towards or away from the screen depending upon the position of the object. (CBSE 2017)
15. Assertion (A): The bottom of a tank or pond, filled with water appears to be raised.
Reason (R): The apparent depth of the tank is given by $1/n$ times the original depth.
- (a) (A) is incorrect and (R) is correct.
- (b) (A) is correct and (R) is incorrect.
- (c) Both (A) and (R) are correct but (R) is not the correct explanation of (A).
- (d) Both (A) and (R) are correct but (R) is the correct explanation of (A).

16. Assertion (A): The shaving mirrors are convex mirrors.
Reason (R): Convex mirror always forms a virtual image.
- (a) (A) is incorrect and (R) is correct.
 - (b) (A) is correct and (R) is incorrect.
 - (c) Both (A) and (R) are correct but (R) is not the correct explanation of (A).
 - (d) Both (A) and (R) are correct but (R) is the correct explanation of (A).

3 Short Answer Questions

1. Refractive indices of medium A, B and C are 1.3, 1.5 and 1.4 respectively. In which of the following the speed of light will be the :
 - (a) fastest
 - (b) slowest and why?
2. A compound lens is made up of two thin lenses having power + 12.5 D and – 2.5 D. Find the focal length and power of the combination.
3. Light enters from air to kerosene having a refractive index of 1.47. What is the speed of light in kerosene ?
4. A 5 cm tall object is placed perpendicular to principal axis of a convex lens of focal length 10 cm. If the object is placed 30 cm away from the lens, find the position, size and nature of image.
5. A ray travelling in water enters obliquely into glass. Does the light bend towards or away from the normal and why ?
6. An object is placed at the focus of a convex lens. Draw ray diagram to locate the position of image formed.
7. If the image formed by a spherical mirror for all positions of the object placed in front of it is always erect and diminished, what type of mirror is it? Draw a labelled ray diagram to support your answer. (CBSE 2018)
8. State the laws of refraction of light. Explain the term 'absolute refractive index of a medium' and write an expression to relate it with the speed of light in vacuum. (CBSE 2018)
9. What is meant by power of a lens? Write its SI unit. A student uses a lens of focal length 40 cm and another of –20 cm. Write the nature and power of each lens. (CBSE 2018)
10. An object is placed at a distance of 15 cm from a concave lens of focal length 30 cm. List four characteristic (nature, position, etc.) of the image formed by the lens. (CBSE 2017)

11. "A lens can form a magnified erect image as well as magnified inverted image of an object placed in front of it". Same the nature of this lens and draw ray diagrams to justify the above statement.
Mark the position of O, F and 2F in the diagram. (2017)
12. The refractive indices of glass and water with respect to air are $\frac{3}{2}$ and $\frac{4}{3}$ respectively. If speed of light in glass is 2×10^8 m/s, find the speed of light in water. (CBSE 2016)
13. One half of a convex lens is covered with black paper.
- Show the formation of image of a object placed at 2F, of such covered lens with the help of ray diagram. Mention the position and nature of the image.
 - Draw the ray diagram for same object at same position in front of the same lens, but now uncovered. Will there be any difference in image obtained in the two cases? Give reasons for your answers.
14. A thin converging lens forms a (i) real magnified image, (ii) virtual magnified image.
- Write the position of object in each case.
 - Draw labelled diagram for each case.
15. (a) What happens to a ray of light when it travels from one medium to another having equal refractive indices?
(b) State the cause of refraction of light.
16. (a) Define 1 dioptre of power. Find the focal length of a lens of power - 2.0 D.
(b) Why does a lemon kept in water in a glass tumbler appear to be bigger than actual size?
17. Analysis the following observation table showing variation of image distance (v) with object distance (u) in case of a convex lens and answer the questions that follow without doing any calculation:

S. No.	Object Distance-u(cm)	Image Distance-v(cm)
1.	-100	+25
2.	-60	+30
3.	-40	+40

S. No.	Object Distance-u(cm)	Image Distance-v(cm)
4.	-30	+60
5.	-25	+100
6.	-15	+120

One half of a convex lens is covered with black paper.

- (a) Show the formation of image of a object placed at $2F$, of such covered lens with the help of ray diagram. Mention the position and nature of the image.
- a) What is the focal length of the convex lens? Give reason to justify your answer.
- b) Write the serial number of the observation which is not correct. On what basis have you arrived at this conclusion?
- c) Select an approximate scale and draw a ray diagram for the observation at S. No. 2 Also find the approximate value of magnification.
18. (a) If the image formed by a mirror for all position of the object placed in front of it is always diminished, erect and virtual, state the type of the mirror and also draw a ray diagram to justify your answer. Write one use such mirrors are put to and why.
- (b) Define the radius of curvature of spherical mirror. Find the nature and focal length of a spherical mirror whose radius of curvature is $+24$ cm.



Competency Based Question

If there is no light, there is no sight!

Apart from looking directly at a light source, most of what we see is as a result of the process of reflection.

Reflection is when light bounces off an object. If the surface is smooth and shiny, like glass, water or polished metal, the light will reflect at the same angle as it hit the surface. This is called specular or regular reflection.

If you look at a bird, light has reflected off that bird and travelled in nearly all directions. This is diffuse reflection. If some of that light enters your eyes, it hits the retina at the back of your eyes. An electrical signal is passed to your brain, and your brain interprets the signals as an image.



- This picture shows
 - Regular Reflection
 - Diffuse Reflection
 - Refraction of light
 - Internal Reflection
-

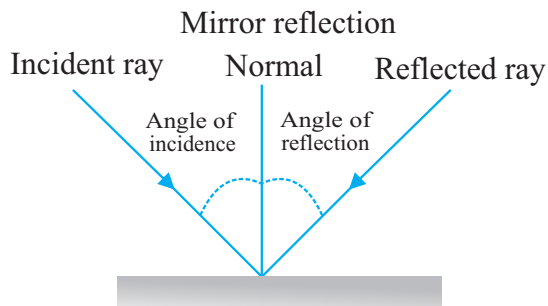

- (a) Angle of incidence $>$ Angle of reflection
- (b) Angle of incidence = Angle of reflection
- (c) Angle of incidence = Angle of reflection
- (d) Angle of incidence $<$ Angle of reflection

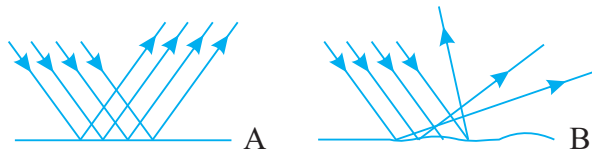

- 3. (a) A shows refraction, B shows reflection
 - (b) A shows reflection, B shows refraction
 - (c) A shows diffuse reflection, B shows internal diffusion
 - (d) A is regular reflection, B shows diffuse reflection
4. State two laws of reflections of light.
5. Distinguish between a real and virtual image of an object. What type of image is formed (i) by a plane mirror (ii) Or a cinema screen.

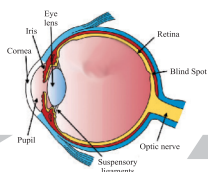

Chapter - 10

The Human Eye and The Colourful World

Human eye : The sense organ that helps us to see.

- Located in eye sockets in skull.
- Diameter of eye ball is 2.3 cm

Parts of Human Eye

Cornea : It is the outermost, transparent part. It provides most of the refraction of light.

Lens : It is composed of a fibrous, jelly like material. Provides the focused real and inverted image of the object on the retina. This is convex lens that converges light at retina.

Iris : It is a dark muscular diaphragm that controls the size of the pupil.

Pupil : It is the window of the eye. It is the central aperture in iris. It regulates and controls the amount of light entering the eye.

Retina : It is a delicate membrane having enormous number of light sensitive cells.

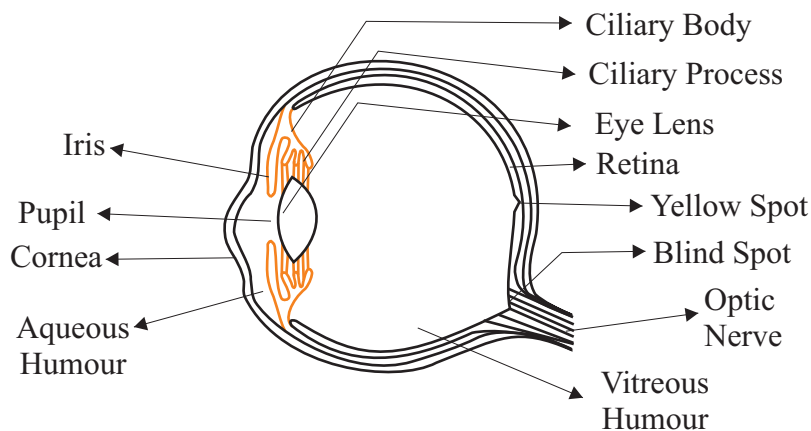

The Structure of human eye

Far point : The maximum distance at which object can be seen clearly is far point of the eye. For a normal adult eye, its value is infinity.

Near point or Least distance of distinct vision:

The minimum distance at which objects can be seen most distinctively without strain.

- For a normal adult eye, its value is 25 cm.
- Range of human vision – 25 cm to infinity.

Accommodation : The ability of the eye lens to adjust its focal length is called accommodation. Focal length can be changed with the help of ciliary muscles.

Myopia (Near sightedness)

- A myopic person can see nearby objects clearly but cannot see distant objects clearly.
- Image is formed in front of retina.
- The far point (F) of a myopic lens is less than infinity.

Causes of Myopia

- Excessive curvature of eye lens
- Elongation of eye ball

Correction

Use of concave lens of appropriate power.

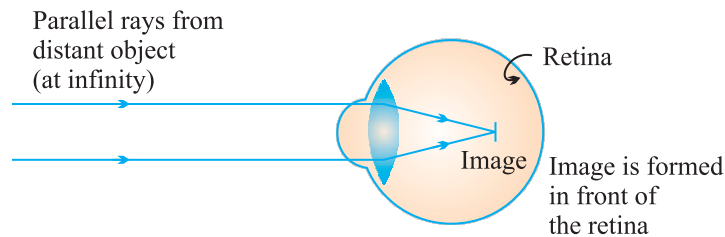

- (a) In a myopic eye, image of distant object is formed in front of the retina (and not on the retina)

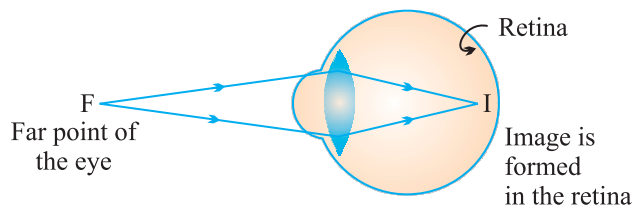

(b) The far point (F) of a myopic eye is less than infinity

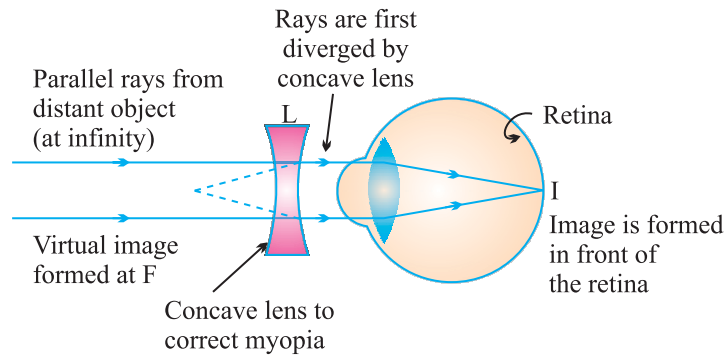

(c) Correction of myopia. The concave lens placed in front of the eye forms a virtual image of distant object at far point (F) of the myopic eye.

Hypermetropia (Far sightedness)

- Affected person can see far objects clearly but cannot see nearby objects clearly.
- The near point of the eye moves away from near point (25 cm)
- Image is formed behind the retina.

Causes of Hypermetropia

- Focal length of the eye lens becomes too long.
- Eye ball becomes too small.

Correction

Use of convex lens of suitable power can correct the defect.

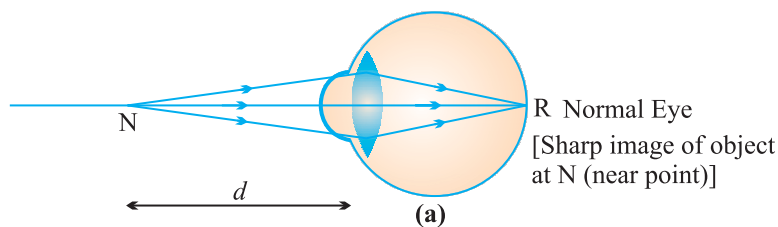

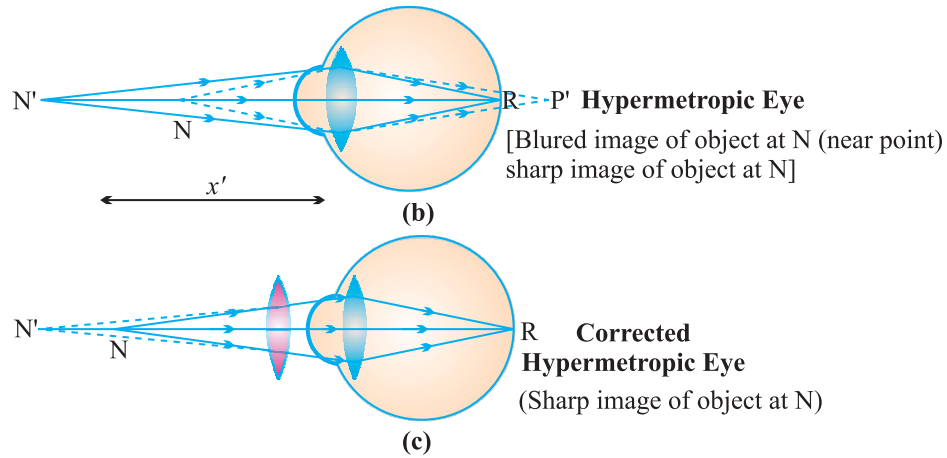

Presbyopia (Old age Hypermetropia)

It is the defect of vision due to which an old person cannot see the nearby objects clearly due to loss of power of accommodation of the eye.

- The near-point of the old person having presbyopia gradually recedes and becomes much more than 25 cm away.

Causes

- Gradual weakening of ciliary muscles.
- Diminishing flexibility of eye lens.

Correction

- Use of both concave and convex lens of suitable power.
- Sometimes a person may suffer from both myopia and hypermetropia.
- Such people require bifocal lens for correction.

Advantage of the eyes in front of the face

- It gives a wider field of view.
- It enhances the ability to detect faint objects.
- It provides three dimensional view.

CHECK YOUR KNOWLEDGE

VERY SHORT ANSWER TYPE QUESTIONS

1. What type of lens is used to correct (a) Hypermetropia, (b) Myopia ?
2. Name the defect of vision in which the eye-lens loses its power of accommodation due to old age.
3. What is the far point of a person suffering from myopia ?
4. What is the other name of old age hypermetropia ?
5. You friend can read a book perfectly well but cannot read the writing on black-board unless she sits on the front row in class. Is she short-sighted or long-sighted ?

SHORT ANSWER TYPE QUESTIONS

1. Differentiate between Hypermetropia and Myopia.
2. What is presbyopia ? Write two causes of this defect. Name the type of lens which can be used to correct presbyopia.
3. The near point of a person suffering from hypermetropia is at 50 cm from his eye. What is the nature and power of the lens needed to correct this defect ?
4. How is the amount of light entering the eye controlled ?
5. (a) What happens to the size of pupil of our eye in (i) dim light, (ii) bright light ?
(b) Name the cells on the retina sensitive to (i) bright light, (ii) dim light.
6. (a) Draw a simple diagram of the human eye and label clearly the cornea, iris, pupil, ciliary muscles, eye lens, retina and optic nerve.
(b) Describe the working of the human eye with the help of the above diagram.
7. What is short sightedness ? State the two causes of short-sightedness. With the help of ray diagrams, show :
(a) the eye defect short sightedness.
(b) correction of short sightedness by using a lens.

Dispersion of-Light by Glass Prism

When white light is passed through a glass prism, it splits into its seven constituent colours to form a band of seven colours. This phenomenon is called dispersion.

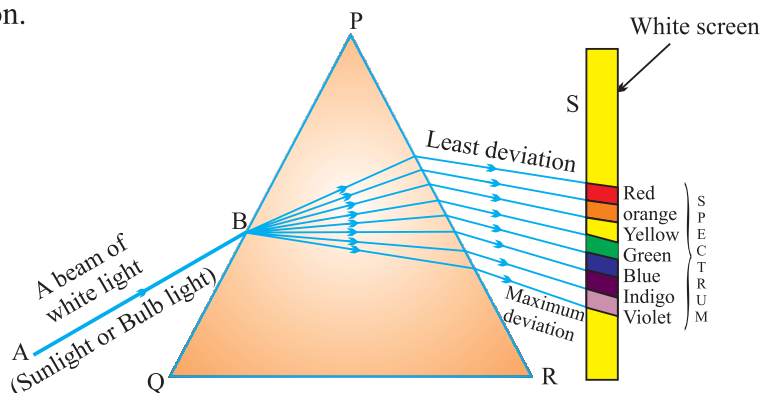

Spectrum : The band of seven colours formed due to dispersion of white light is called spectrum.

Acronym : It is a group of alphabets that represent sequential colours in spectrum.

V I B G Y O R

$$\text{Angle of deviation} \propto \frac{1}{\text{wavelength}}$$

- Red is the **least deviated** colour as it has largest/longest wavelength.
- Violet is the **most deviated** colour as it has smallest wavelength in visible spectrum.

Q. Why spectrum is formed when white light is passed through a glass prism ?

Ans. Each colour has a definite wavelength and for each wavelength the angle of deviation differs. Red is the least deviated and violet is the most deviated colour so different colours deviate at different angles to form spectrum.

Prism : It is a pyramidal piece of glass with two triangular bases and three rectangular lateral surfaces.

Angle of Prism : The angle between two adjoining lateral surfaces.

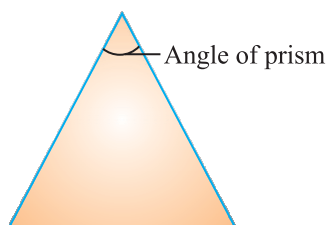

Refraction through a glass prism

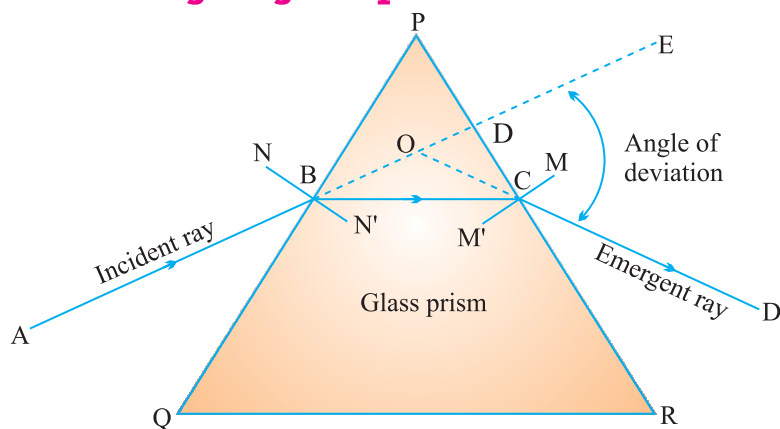

Angle of deviation (d) : It is the angle between incident ray and emergent ray.

Issac Newton was the first person who proved that sunlight is made up of seven colours :

- (i) He passed sunlight through a glass prism to form a band of seven colours.
- (ii) He tried to split the colours further by putting another prism ahead of the prism forming spectrum but he failed to obtain more colours.
- (iii) He formed a spectrum from sunlight and placed an identical but inverted prism in front of prism forming the spectrum. All the seven colours combined by the inverted prism and emerged as white light.

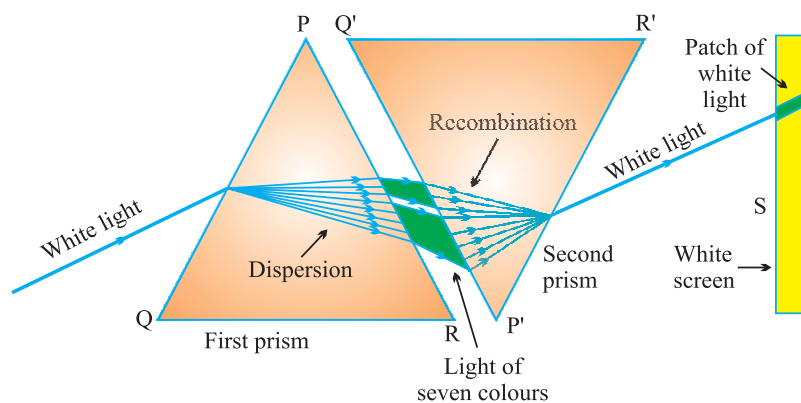

Q. What is referred as white light ?

Ans. Any light that forms a spectrum similar to that of sunlight is referred as white light.

Total Internal Reflection

When light enters obliquely from a denser medium to a rarer medium and the angle of incidence exceeds critical angle, the light reflects in the denser medium. This is called internal reflection.

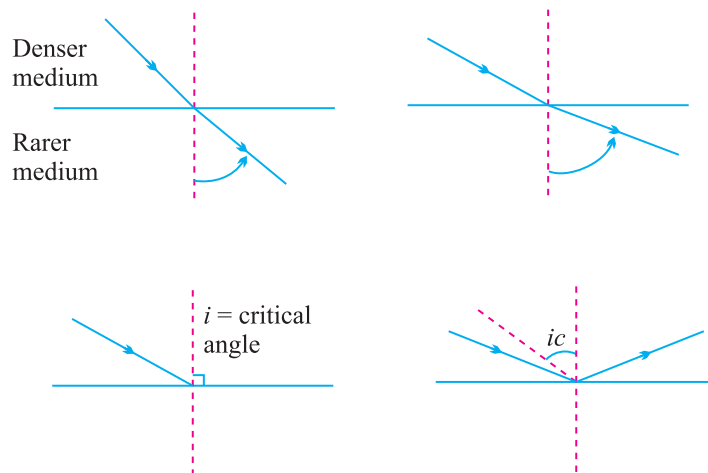

Conditions necessary for Internal Reflection

- (i) Light should enter obliquely from a denser to a rarer medium.
- (ii) The angle of incidence should exceed critical angle, the light reflects in the denser medium.

Critical angle : The angle of incidence for which the angle of refraction is 90° .

Rainbow : It is a natural spectrum appearing in the sky after rain showers.

- Rainbow is observed in the direction opposite to the sun.
- Three phenomenon which are involved in rainbow formation are :
 - (a) Dispersion
 - (b) Refraction
 - (c) Internal reflection

Formation of Rainbow :

Some water droplets remain suspended in air after rain. These droplets behave as glass prism. When light enters the rain drop, it first refracts and disperses. Then it reflects internally and again refracts as it comes out of the drop and the seven colours reach the eye of observer in form of rainbow.

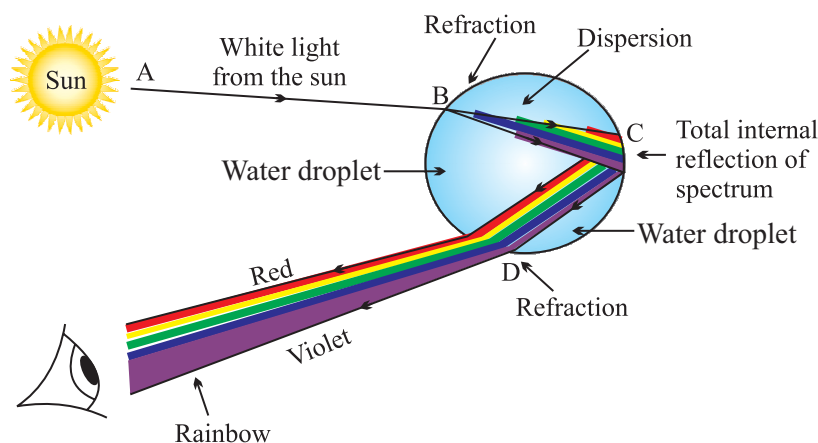

Atmospheric Refraction : The refraction by different layers of atmosphere is called atmospheric refraction.

- (i) Apparent flickering of objects placed behind a hot object or fire.
 - (ii) Stars near the horizon appear slightly higher than their actual position.
 - (iii) Advanced sunrise and delayed sunset.
 - (iv) Twinkling of stars.
-
- (i) *An object placed behind the fire or a hot surface appears to flicker when seen through the air .*

The air above hot surface becomes hot and rises. The space is occupied by cool air. The refractive index of hot air is less than that of cool air. So, the physical condition of the medium are not constant. Due to changing Refractive Index (RI) of medium, the light appears to come from different directions.

It results in fluctuation in apparent position of object.

(ii) Stars when seen near the horizon appear slightly higher than their actual position due to atmospheric refraction.

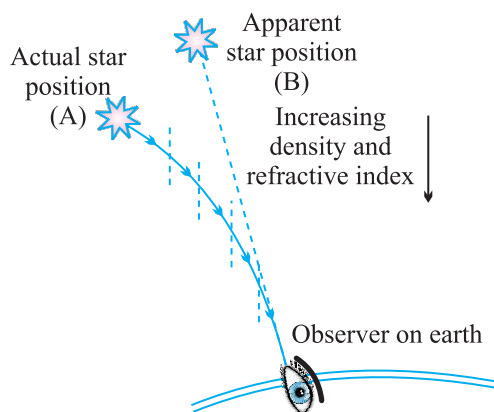

The refractive index of earth's atmosphere in general increases from top to bottom. So, the light coming from a star near the horizon has to travel from rarer to denser medium and it bends towards the normal. As a result the star appears higher.

(iii) Advanced sunrise

The sun appears about two minutes earlier than actual sunrise and the sun remains visible for about two minutes after actual sunset.

When the sun is below horizon, the rays have to pass from rarer to denser medium. So rays bend towards the normal. As a result the sun appears higher than its actual position.

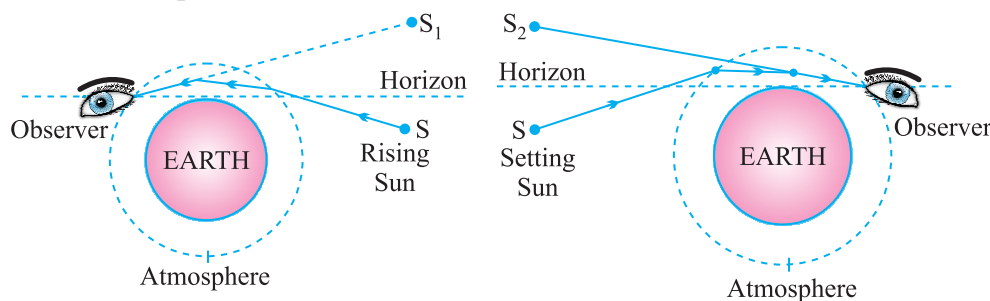

(iv) Twinkling of stars

Stars are very far from us, so they behave as point source of light. Since the physical conditions of the earth's atmosphere are not constant the light from stars appears to come from different directions. This results in fluctuation of apparent position of star.

The amount of light coming from stars also vary due to changing Refractive Index of atmosphere.

The star appears bright when more light from star reaches our eyes and the same star appears dull when less amount of light reaches our eyes.

Both these effects are responsible for twinkling of stars.

Scattering effect : Spreading of light in various directions by colloid particles.

Law of Rayleigh

$$\text{Scattering} \propto \frac{1}{(\text{wavelength})^4}$$

Tyndall effect : When light passes through a colloid its path becomes visible. This is called **Tyndall effect**.

E.g.,

- (i) Path of light becomes visible when light enters a dark and dusty room through a slit or ventilator.
- (ii) Path of light becomes visible when light passes through dense canopy of trees in a forest.

The colour of scattered light depends on the size of scattering particles

- (i) If particles are very fine, they scatter mainly the blue colour of light (shorter wavelength).
 - (ii) Medium sized particles scatter mainly the red colour (longer wavelength).
 - (iii) Even larger particles scatter all the colours of light that is why it appears white.
- Wavelength of red light is about 1.8 times to that of blue light.

Q. *Why danger signs are made of red colour ?*

Ans. Red is the least scattered colour. It is least scattered by fog and smoke and can be seen in the same colour over a long distance. So, danger signs are made in red colour.

Q. *Why the colour of sky appears blue on a clear day ?*

Ans. The upper layer of atmosphere contains very fine particles of water vapours and gases. These particles are more effective in scattering of light of shorter wavelength mainly blue than larger wavelength. So, the sky appears blue.

Q. *How does the sky appear to an astronaut in the space or to a passenger of jet plane flying at high altitude ?*

Ans. The sky would appear dark to an astronaut in the space as scattering is not very prominent at such high altitude due to absence of particles.

Q. *Why clouds appear white ?*

Ans. Clouds are formed by water vapours. Water vapours condense to form water droplets due to larger size of droplets, all colours of light are scattered and clouds appear white.

Q. *Why colour of sun appear red during sunrise and sunset ?*

Ans. While sunset and sunrise, the colour of the sun and its surrounding appear red. During sunset and sunrise, the sun is near horizon and therefore the sunlight has to travel larger distance in atmosphere. Due to this most of the blue light (shorter wavelength) are scattered away by the particles. The light of longer wavelength (red colour) will reach our eye. This is why sun appear red in colour.

Q. *Why do planets not twinkle ?*

Ans. The planets are much closer to the earth and are thus seen as extended source. If we consider a planet as a collection of a large number of point-sized sources of light, the total variation in the amount of light entering our eye from all individual point sized sources will average out to zero and will nullify the twinkling effect.

QUESTIONS

1 MARKER OBJECTIVE QUESTIONS

I. MULTIPLE CHOICE QUESTIONS

- The image formed retina of human eye is
 - Virtual and erect
 - Real and inverted
 - Virtual and inverted
 - Real and erect
- The change in the focal length of human eye is caused due to
 - Ciliary muscles
 - Pupil
 - Cornea
 - Iris
- The least distance of distinct vision for a young adult with normal vision is
 - 25 m
 - 20 m
 - 25 cm
 - 20 cm
- The persistence of vision for human eye is
 - 1/10th of a second
 - 1/16th of a second
 - 1/6th of the second
 - 1/18th of a second
- The light sensitive cells of retina which are sensitive to the intensity of light are—
 - Cones
 - Rods
 - Both rods and cones
 - None of these
- A person cannot see distinctly objects kept beyond 2 m. This defect can be corrected by using lens of power-
 - +0.5 D
 - 0.5 D
 - +0.2 D
 - 0.2 D
- A student sitting on the last bench can read the letters written on the blackboard but is not able to read / the letters written in his textbook. Which of the following statements is correct?
 - The near point of his eyes has receded away.
 - The near point of his eyes has come closer to him.

VERY SHORT ANSWER TYPE QUESTIONS

1. Which of the two is scattered more easily – light of shorter wavelength or light of longer wavelength ?
2. What is the near and far point of a normal eye ?
3. State two effects produced by the scattering of light by the atmosphere.
4. What is tyndall effect ?
5. Which light has longer wavelength – red light or blue light ?
6. What do you understand by dispersion of light ?
7. As light rays pass from air into a glass prism, are they refracted towards or away from the normal ?
8. Assertion (A): Some persons have the difficulty to see the objects in dim light during night.
Reason (R): Cones respond less to the illumination.
 - (a) (A) is incorrect and (R) is correct.
 - (b) (A) is correct and (R) is incorrect.
 - (c) Both (A) and (R) are correct but (R) is not the correct explanation of (A).
 - (d) Both (A) and (R) are correct but (R) is the correct explanation of (A).
9. Assertion (A): The colour of the clear sky appears blue.
Reason (R): The sky of the moon appears dark.
 - (a) (A) is incorrect and (R) is correct.
 - (b) (A) is correct and (R) is incorrect.
 - (c) Both (A) and (R) are correct but (R) is not the correct explanation of (A).
 - (d) Both (A) and (R) are correct but (R) is the correct explanation of (A).
10. Assertion (A): The human eye has more field of view.
Reason (R): For a normal eye, the farthest point upto which the eye can see objects clearly is infinity.
 - (a) (A) is incorrect and (R) is correct.
 - (b) (A) is correct and (R) is incorrect.
 - (c) Both (A) and (R) are correct but (R) is not the correct explanation of (A).
 - (d) Both (A) and (R) are correct but (R) is the correct explanation of (A).

11. A student very cautiously traces the path of a ray through a glass slab for different values of the angle of incidence ($\angle i$). He then measures the corresponding values of the angle of incidence. On analysing these measurements of angles, his conclusion would be

(A) $\angle i > \angle r > \angle e$

(B) $\angle i = \angle e > \angle r$

(C) $\angle i < \angle r < \angle e$

(D) $\angle i = \angle e < \angle r$

Sol. (B) $\angle i = \angle e > \angle r$

SHORT ANSWER TYPE QUESTIONS

1. Why do stars twinkle at night ?
2. Describe the formation of rainbow in the sky with the help of a diagram.
3. Why the sun appear red while sunset and sunrise ? Explain.
4. Why do stars seem higher than they actually are ? Illustrate your answer with the help of a diagram.
5. What is "dispersion of white light"? Draw a labelled diagram to illustrate the recombination of the spectrum of white light. Why it is essential that the two prisms used for the purpose should be identical and placed in an inverted position with respect to each other? (CBSE 2017)
6. With the help of scattering of light, explain the reason for the difference in colours of the Sun as it appears during sunset/sunrise and noon. (CBSE 2015)
7. Write the importance of ciliary muscles in the human eye. Name the defect of vision that arises due to gradual weakening of the ciliary muscles. What types of lenses are required by the person suffering from this defect to see the objects clearly. (CBSE 2015)
8. (a) A student is unable to see clearly the words written on the black board placed at a distance of approximately 3 m from him. Name the defect of vision the boy is suffering from. State the possible causes of this defect and explain the method of correcting it.
9. (a) Write the function of each of the following parts of human eye:
(i) Cornea (ii) Iris (iii) Crystalline (iv) Ciliary muscles
(b) Why does the sun appear reddish early in the morning? Will this phenomenon be observed by an astronaut on the Moon? Give reason to justify your answer.

- 10 (a) A student suffering from myopia is not able to see distinctly the object placed beyond 5 m. List two possible reasons due to which this defect of vision may have arisen. With the help of ray diagrams explain.
- Why the student is unable to see distinctly the objects placed beyond 5 cm from his eyes.
 - The type of the corrective lens used to restore proper vision and how this defect is correct by the use of this lens
- 10 (b) If, in this case, the numerical value of the focal length of the corrective lens is 5 m, find the power of the lens as per the new Cartesian sign convention.
11. What is atmospheric refraction ? What causes atmospheric refraction ?
12. Draw a neat and labelled diagram of the experimental set-up for observing the scattering of light in a colloidal solution of sulphur to show how the sky appears blue and the sun appears red at sunrise and sunset.
- (CBSE 2018)

Competency Based Questions

1. Which natural phenomena is being shown here?

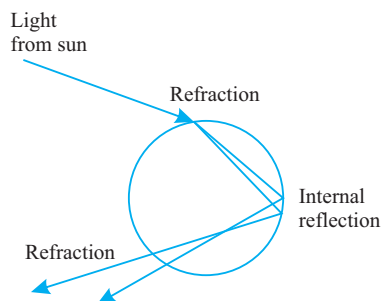

- Twinkling of stars
 - Rainbow formation
 - reddish appearance of the sun early in the morning
 - blue colour of sky
2. Which of the following conditions are necessary for this phenomenon?
- The Sun should be behind us.
 - It should have rained and the Sun should be present.

- c) None of A and B
 - d) Both A and B
3. Dispersion of white light by the glass prism shows-
- a) Spectrum
 - b) Tyndall effect
 - c) Twinkling of stars
 - d) Delayed sunset
4. A glass prism is able to produce a spectrum while white light passes through it but a glass slab does not produce any spectrum. Why?
5. Why do different components of white light deviate through a triangular glass prism?

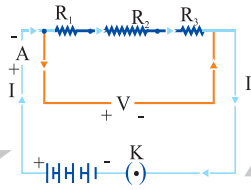

Chapter - 11

Electricity

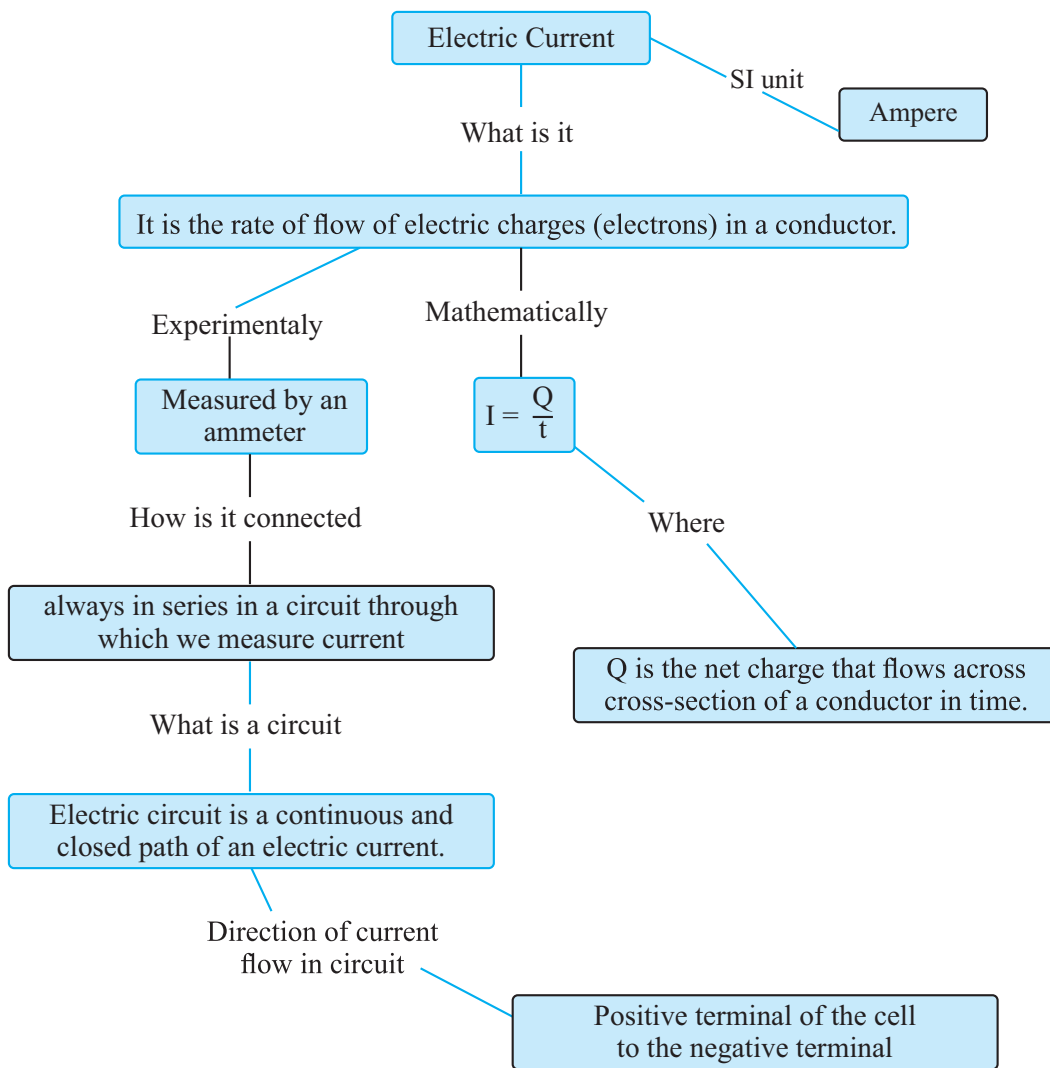

- **Charge** is a fundamental particle in an atom. It may be positive or negative.
- Like charges repel each other.
- Unlike charges attract each other.

coulomb (C) : S. I. unit of charge

1 coulomb charge = Charge present on approx. 6×10^{18} electrons

- Charge on 1 electron = Negative charge of 1.6×10^{-19} C

$$Q = ne$$

Where Q = Charge (total)

n = No. of electrons

e = Charge on 1 electron

Current (I) : The rate of flow of charge is called current.

$$\text{Current} = \frac{\text{Charge}}{\text{Time}}$$

$$I = \frac{Q}{t}$$

S. I. unit of current = Ampere (A)^t

$$1 \text{ A} = 1 \text{ Cs}^{-1}$$

$$1 \text{ mA} = 10^{-3} \text{ A}$$

$$1 \mu\text{A} = 10^{-6} \text{ A}$$

Current is measured by Ammeter. Its symbol is $\overset{+}{\text{---}} \text{ A} \text{ ---}$

Ammeter has low resistance and always connected in series.

Direction of current is taken opposite to flow of electrons as electrons were not known at the time when the phenomenon of electricity was discovered first and current was considered to be flow of positive charge.

Potential Difference (V) : Work done to move a unit charge from one point to another.

$$V = \frac{W}{Q}$$

1 volt : When 1 joule work is done in carrying one Coulomb charge then potential difference is called 1 volt.

S. I. unit of Potential difference = Volt (V)









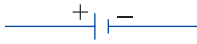

$$1 \text{ V} = 1 \text{ JC}^{-1}$$

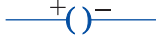
1 Volt : When 1 joule work is done in carrying one coulomb charge then potential difference is called 1 volt.

Voltmeter : Instrument to measure potential difference.

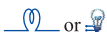
- It has high resistance and always connected in parallel. Symbol is V.
- Cell is the simplest device to maintain potential difference.
- Current always flow from higher potential to lower potential.

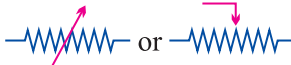
Symbols of Some Commonly Used Components in Circuit :

Electric cell	:	
Battery	:	
Key (open)	:	
Key (closed)	:	
Wire joint	:	
Wire Crossing (without join)	:	
Electric bulb	:	
Resistance	:	
Rheostat	:	
Ammeter	:	

Voltmeter : $\text{---} + \text{V} \text{---}$

Ohm's Law : Potential difference across the two points of a metallic conductor is directly proportional to current passing through the circuit provided that temperature remains constant.

- Mathematical expression for Ohm's law :

$$V \propto I$$

$$V = IR$$

R is a constant called resistance for a given metal.

- V-I graph for Ohm's law :

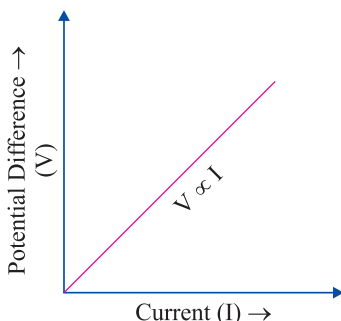

Resistance (R) : It is the property of a conductor to resist the flow of charges through it.

- Ohm (Ω) : S. I. unit of resistance.
- $1 \text{ ohm} = \frac{1 \text{ volt}}{1 \text{ ampere}}$ *When potential difference is 1 V and current through the circuit is 1 A, then resistance is 1 ohm.*

Rheostat : Variable resistance is a component used to regulate current without changing the source of voltage.

Factors on which the Resistance of a Conductor depends :

Resistance of a uniform metallic conductor is

- directly proportional to the length of conductor,
- inversely proportional to the area of cross-section,
- directly proportional to the temperature and
- depend on nature of material.

Resistivity (ρ) : It is defined as the resistance offered by a cube of a material of side 1 m when current flows perpendicular to its opposite faces.

- Its S.I. unit is ohm-metre (Ωm).
- Resistivity does not change with change in length or area of cross-section but it changes with change in temperature.
- Range of resistivity of metals and alloys is 10^{-8} to 10^{-6} Ωm .
- Range of resistivity of insulators is 10^{12} to 10^{17} Ωm .
- Resistivity of alloy is generally higher than that of its constituent metals.
- Alloys do not oxidize (burn) readily at high temperature, so they are commonly used in electrical heating devices.
- Copper and aluminium are used for electrical transmission lines as they have low resistivity.

Resistors in Series :

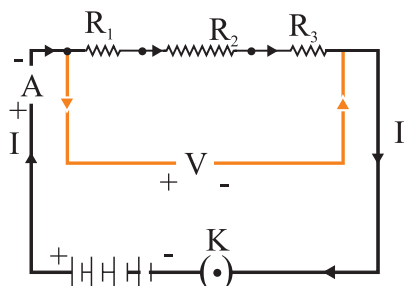

When two or more resistors are connected end to end, the arrangement is called series combination.

- Total/resultant/overall/effective resistance in series

$$R_s = R_1 + R_2 + R_3$$

- Current through each resistor is same.
- Equivalent resistance is larger than the largest individual resistance.
- Total voltage = Sum of voltage drops

$$V = V_1 + V_2 + V_3$$

- Voltage across each resistor :

$$V_1 = IR_1$$

$$V_2 = IR_2$$

$$V_3 = IR_3$$

$$V = IR_1 + IR_2 + IR_3$$

$$[V_1 + V_2 + V_3 = V]$$

$$V = IR$$

\Rightarrow

$$IR = I(R_1 + R_2 + R_3)$$

\Rightarrow

$$R = R_1 + R_2 + R_3$$

Resistors in Parallel :

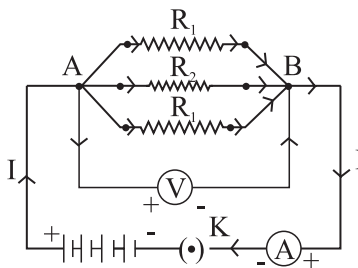

- Voltage across each resistor is same and equal to the applied voltage.
- Total current is equal to sum of currents through the individual resistances.

$$I = I_1 + I_2 + I_3$$

$$\frac{V}{R} = \frac{V}{R_1} + \frac{V}{R_2} + \frac{V}{R_3}$$

- Reciprocal of equivalent resistance is equal to sum of reciprocals of individual resistances.

$$\frac{1}{R_p} = \frac{1}{R_1} + \frac{1}{R_2} + \frac{1}{R_3}$$

- Equivalent resistance is less than the value of the smallest individual resistance in the combination.

Advantages of Parallel Combination over Series Combination

- In series circuit, when one component fails, the circuit is broken and none of the component works.
- Different appliances have different requirement of current. This cannot be satisfied in series as current remains same.
- The total resistance in a parallel circuit is decreased.

Heating Effect of Electric Circuit

If an electric circuit is purely resistive, the source of energy continually get dissipated entirely in form of heat. This is known as heating effect of electric current.

As $E = P \times T \Rightarrow t VI$ $\{E = H\}$
 Or Heat produced, $H = VI t$ $\{V = IR\}$
 Or Heat produced, $H = I^2 R t$

Joule's Law of Heating Effect of Electric Current

It states that the heat produced in a resistor is

- (i) directly proportional to square of current, $H \propto I^2$
- (ii) directly proportional to resistance for a given current, $H \propto R$
- (iii) directly proportional to time for which current flows through the conductor,
 $H \propto t$.

So, $H = I^2 R t$

- Heating effect is desirable in devices like electric heater, electric iron, electric bulb, electric fuse, etc.
- Heating effect is undesirable in devices like computers, computer monitors (CRT), TV, refrigerators etc.
- In electric bulb, most of the power consumed by the filament appears as heat and a small part of it is radiated in form of light.
- *Filament of electric bulb is made up of tungsten as*
 - (i) it does not oxidise readily at high temperature.
 - (ii) it has high melting point (3380° C).
- The bulbs are filled with chemically inactive gases like nitrogen and argon to prolong the life of filament.

Electric Fuse : It is a safety device that protects our electrical appliances in case of short circuit or overloading.

- Fuse is made up of pure tin or alloy of copper and tin.
- Fuse is always connected in series with live wire.
- Fuse has low melting point.
- Current capacity of fuse is slightly higher than that of the appliance.

Electric Power : The rate at which electric energy is consumed or dissipated in an electric circuit.

$$P = VI$$

$$P = I^2 R = \frac{V^2}{R}$$

S.I. unit of power = watt (W)

$$1 \text{ watt} = 1 \text{ volt} \times 1 \text{ ampere}$$

- Commercial unit of electric energy = kilo watt hour (kWh)

$$1 \text{ kWh} = 3.6 \times 10^6 \text{ J}$$

$$1 \text{ kWh} = 1 \text{ unit of electric energy}$$

QUESTIONS

VERY SHORT ANSWER TYPE QUESTIONS (1 Mark)

1. Define S.I. unit of :
 - (a) Electric current
 - (b) Potential difference
 - (c) Resistance
 - (d) Electric power
 - (e) Electrical energy consumed
2. Define the term resistivity.
3. Device used for measuring the current is.....
4. Name the element of filament of a bulb.
5. Write two types of resistors combination.
6. How the voltmeter is connected in a circuit ?
7. How the ammeter is connected in a circuit?
8. Why the filament of bulb has high melting point ?
9. How does fuse wire protect electrical appliances ?
10. Define IKWh in terms of units
11. On what factors does resistance of a conductor depend ?

I. MULTIPLE CHOICE QUESTIONS

12. What is the rate of flow of electric charges called?
 - a) Electric potential
 - b) Electric conductance
 - c) Electric current
 - d) None of these
13. Which of the following is the SI Unit of Electric Current?
 - a) ohm
 - b) ampere
 - c) volt
 - d) faraday
14. Which instrument is used for measuring electric potential?
 - a) Ammeter
 - b) Galvanometer
 - c) Voltmeter
 - d) Potentiometer

15. When one unit electric charge moves from one point in an electric circuit, then the amount of work done in joules is known as?
- a) Electric current
 - b) Electric resistance
 - c) Electric conductance
 - d) Potential difference
16. The hindrance presented by material of conductor to the smooth passing of electric current is known as:
- a) Resistance
 - b) Conductance
 - c) Inductance
 - d) None of these
17. The resistance of a conductor is directly proportional to:
- a) Its area of cross-section
 - b) Density
 - c) Melting
 - d) Length
18. The purpose of a rheostat is:
- a) Increase the magnitude of current only
 - b) Decrease the magnitude of current only
 - c) Increase or decrease the magnitude of current
 - d) None of these
19. Point to be kept in mind for verification of Ohm's Law is:
- a) Ammeter and voltmeter should be connected in series
 - b) Ammeter should be connected in series and voltmeter in parallel
 - c) Ammeter should be connected in parallel and voltmeter in series
 - d) Ammeter and voltmeter should be connected in parallel
20. A fuse wire is inserted in a?
- a) Live wire
 - b) In the neutral wire
 - c) In the earth wire
 - d) May be connected in any line
21. When electric current is passed, electrons move from:
- (a) high potential to low potential.
 - (b) low potential to high potential.
 - (c) in the direction of the current.
 - (d) against the direction of the current.

Very Short Answer Type Questions:

1. What is electricity?
2. What is the SI unit of electric charge?
3. What is the SI unit of electric current?
4. Which device is used for measuring electric current?
5. An ammeter is attached to the circuit in which combination?

SHORT ANSWER TYPE QUESTIONS

1. State Ohm's law. Derive relation between I , V and R . Draw the graph between V and I .
2. What is Joule's heating effect of current P ? Derive its expression.
3. What would be new resistance if length of conductor is doubled and thickness is halved?
4. Find the effective resistance between A and B.

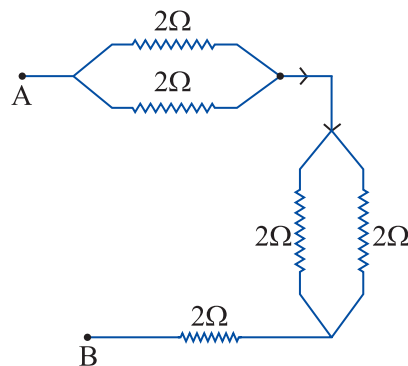
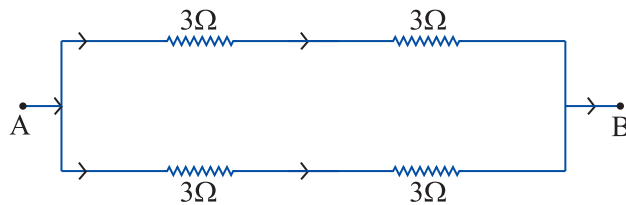
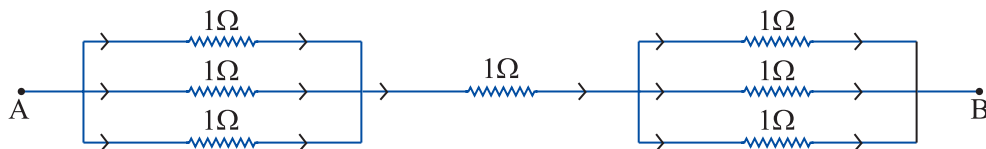

5. Which is the better way to connect lights and other appliances in domestic wiring and why ?
6. Explain the Joule's law of heating. How and on what factors does the heat produced in a conductor depends ?
7. In the circuit given below, calculate :

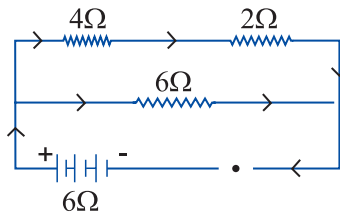

- (a) Total effective resistance.
 - (b) Potential difference across 4Ω , 2Ω .
8. Three resistances of 2Ω , 3Ω and 5Ω are connected in electric circuit. Find :
 - (a) maximum effective resistance.
 - (b) minimum effective resistance.
 9. On what factors, the resistance of a conductor depends ? Give the mathematical expression. Give the SI unit of resistivity.

Competency Based Question:

The Government of India ordered a nationwide lockdown for 3 weeks on 25th March, 2020 to control the spread of COVID-19. The lockdown has been extended with gradual relaxation. It had a significant impact on the electricity demand due to reduction in commercial and industrial activities. The all India electricity consumption dropped by 22% in the first week of lockdown as compared to the peak of the previous week. In the initial lockdown period, the daily electricity consumption was 25-30% lower than its corresponding value in 2019 (see Figure 1). The residential electricity consumption, on the other hand, is expected to have increased during the lockdown as people spent more time at home.

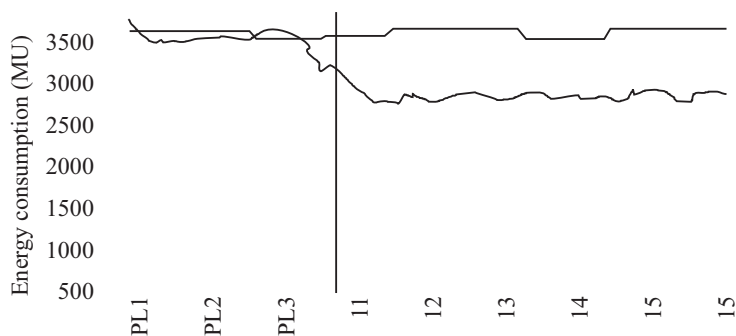
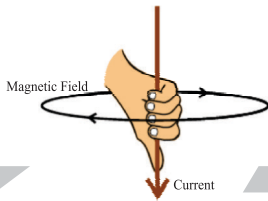

Figure 1: Daily all India electricity consumption (MUs)

1. What is the probable reason of fluctuation in electricity consumption in 2020 as compared to 2019.
 - a) reduction in commercial and industrial activities
 - b) people spent more time at home.
 - c) both of these
 - d) There is no change in electricity consumption.

Appliance	watts	hours/Month	kWh/Month
Ceiling Fan	65	15-730	1-47
Electric Heater	1200	30-90	36-108
Iron	1000	1-10	1-10
Washing Machine	1800	7-40	13-72
Computer (Monitor & Printer)	200	25-160	5-32

2. 'watt is the S.I. unit of-
- a) electric current b) power
c) potential difference d) Energy
3. Electricity bills come in terms of units of electricity which have been consumed.
Here, 1 Unit =
- a) 3.6×10^5 joules
b) 3.6×10^5 watts
c) 3.6×10^6 watts
d) 3.6×10^6 joules
4. Total energy consumed is given by-
- a) $E = QXt$ b) $E = Q/t$
c) $E = P X t$ d) $E = P/t$
5. A 4kW electric heater is connected to a 220V source of power. What will be the amount of energy, it will consume in 2hrs ?



Chapter - 12

Magnetic Effects Of Electric Current

Magnet is any substance that attracts iron or iron-like substances.

Properties of Magnet

- (i) Every magnet has two poles *i.e.*, North and South.
- (ii) Like poles repel each other.
- (iii) Unlike poles attract each other.
- (iv) A freely suspended bar magnet aligns itself in nearly north-south direction, with its north pole towards north direction.

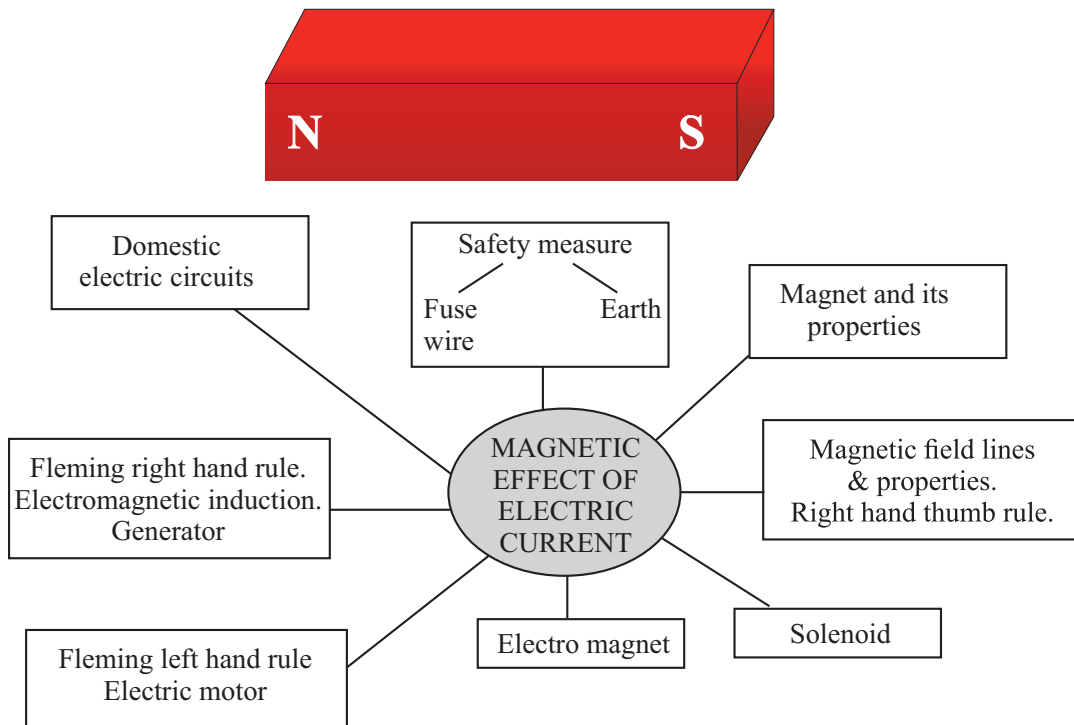

Magnetic Field : The area around a magnetic in which its magnetic force can be experienced.

- Its SI unit is Tesla (T).

✓Magnetic field has both magnitude and direction.

✓Magnetic field can be described with help of a magnetic compass.

- The needle of a magnetic compass is a freely suspended bar magnet.

Characteristics of Field Lines

(i) Field lines arise from North pole and end into South pole of the magnet.

(ii) Field lines are closed curves.

(iii)Field lines are closer in stronger magnetic field.

(iv)Field lines never intersect each other as for two lines to intersect, there must be two north directions at a point, which is not possible.

(v) Direction of field lines inside a magnet is from South to North.

(vi)Therelative strength of magnetic field is shown by degree of closeness of field lines.

Magnetic Field of a Bar Magnet

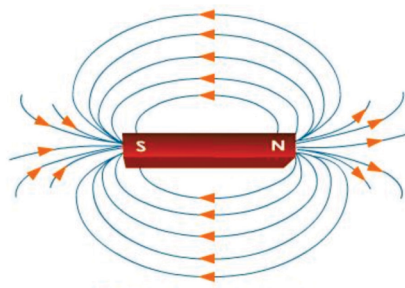

- H. C. Oersted was the first person to state that electric current has magnetic field.

Right Hand Thumb Rule

Imagine you are holding a current carrying straight conductor in your right hand such that the thumb is pointing towards the direction of current. Then the fingers wrapped around the conductor give the direction of magnetic field.

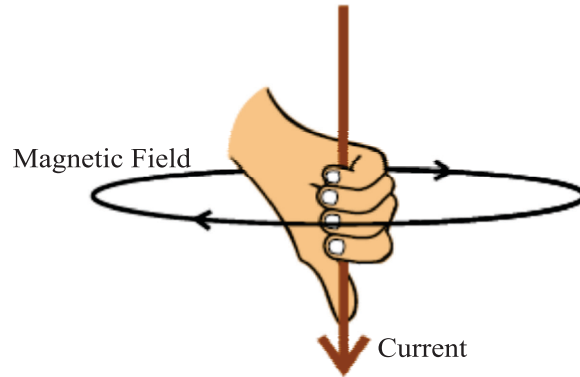

Magnetic Field Due to Current Through a Straight Conductor

- It can be represented by concentric circles at every point on conductor.
- Direction can be given by right hand thumb rule or compass.
- Circles are closer near the conductor.
- Magnetic field \propto Strength of current
- Magnetic field $\propto \frac{1}{\text{Distance from conduction}}$

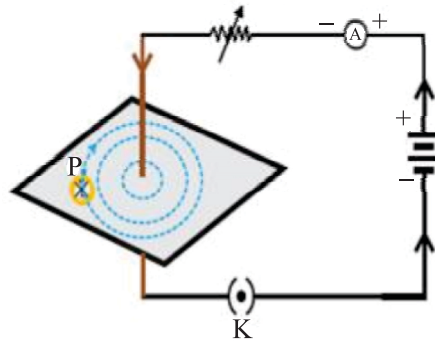

Magnetic Field Due to Current Through a Circular Loop

- It can be represented by concentric circle at every point.
- Circles become larger and larger as we move away.
- Every point on wire carrying current would give rise to magnetic field appearing as straight line at centre of the loop.
- The direction of magnetic field inside the loop is same.

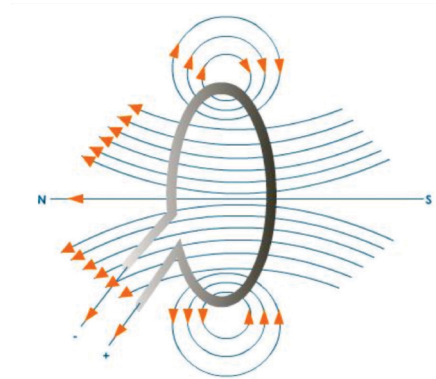

Factors affecting magnetic field of a circular current carrying conductor

- Magnetic field \propto Current passing through the conductor
- Magnetic field $\propto \frac{1}{\text{Distance from conduction}}$
- Magnetic field \propto No. of turns in the coil

Magnetic field is additive in nature *i.e.*, magnetic field of one loop adds up to magnetic field of another loop. This is because the current in each circular turn has some direction.

Solenoid

A coil of many circular turns of insulated copper wire wrapped closely in a cylindrical form.

- Magnetic field of a solenoid is similar to that of a bar magnet.
- Magnetic field is uniform inside the solenoid and represented by parallel field lines.
- Direction of magnetic field
 - (i) Outside the solenoid : North to South
 - (ii) Inside the solenoid : South to North
- Solenoid can be used to magnetise a magnetic material like soft iron.

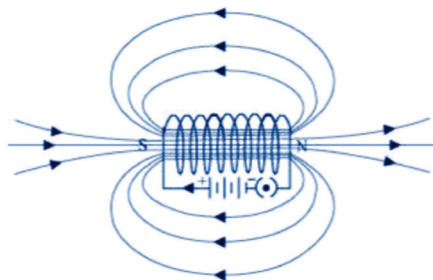

Electromagnet

1. It is a temporary magnet, so, can be easily demagnetised.
2. Strength can be varied.
3. Polarity can be reversed.
4. Generally strong magnet.

Permanent Magnet

1. Cannot be easily demagnetised.
2. Strength is fixed.
3. Polarity cannot be reversed.
4. Generally weak magnet.

Force on a Current carrying Conductor in a Magnetic Field

Andre Marie Ampere suggested that the magnet also exerts an equal and opposite force on a current carrying conductor.

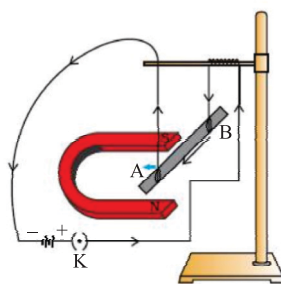

The displacement in the conductor is the maximum when the direction of current is at right angle to the direction of magnetic field.

Direction of force is reversed on reversing the direction of current.

Fleming's Left Hand Rule

Stretch the thumb, fore finger and middle finger of your left hand such that they are mutually perpendicular. If fore finger points in the direction of magnetic field, middle finger in the direction of current then thumb will point in the direction of motion or force.

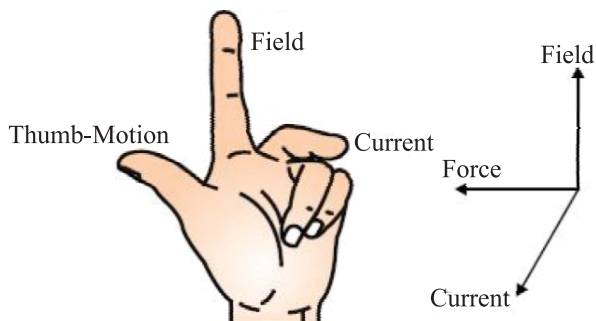

Domestic Electric Circuits

- There are three kinds of wires used :
 - (i) Live wire (positive) with red insulation cover.
 - (ii) Neutral wire (negative) with black insulation cover.
 - (iii) Earth wire with green insulation cover.
- The potential difference between live and neutral wire in India is 220 V.
- Pole → Main supply → Fuse → Electricity meter → Distribution box → To separate circuits

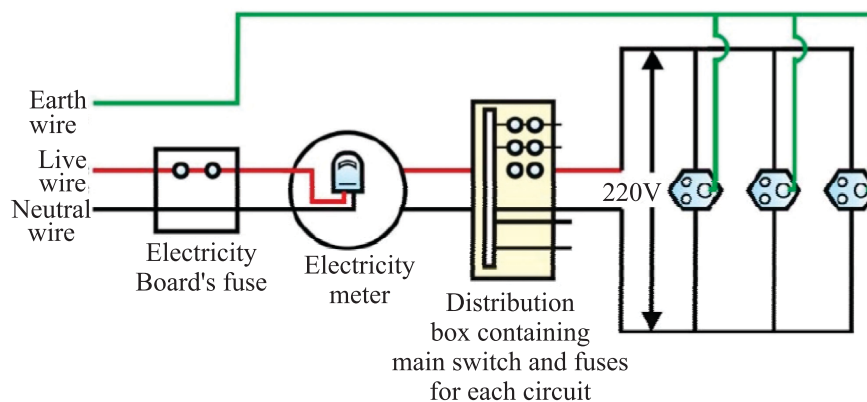

Earth Wire : Protects us from electric shock in case of leakage of current especially in metallic body appliances. It provides a low resistance path for current in case of leakage of current.

Short Circuit : When live wire comes in direct contact with neutral wire accidentally.

- Resistance of circuit becomes low.
- Can result in overloading.

Overloading : When current drawn is more than current carrying capacity of a conductor, it results in overloading.

Causes of overloading :

- (i) Accidental hike in voltage supply.
- (ii) Use of more than one appliance in a single socket.

Safety devices :

- (i) Electric fuse
- (ii) Earth wire
- (iii) MCB (Miniature Circuit Breaker)

QUESTIONS

VERY SHORT ANSWER TYPE QUESTIONS

1. Define magnetic field lines.
2. What is the frequency of a.c. in India ?
3. What is short circuit ?
4. Why do two magnetic field lines not intersect ?
5. What should be the core of an electromagnet?
 - a) Soft iron
 - b) Hard iron
 - c) Rusted iron
 - d) None of above
6. Who has stated the Right hand Thumb Rule?
 - a) Oersted
 - b) Fleming
 - c) Einstein
 - d) Maxwell
7. In all the electrical appliances, the switches are put in the
 - a) Live wire
 - b) Earth wire
 - c) Neutral wire
 - d) All of above
8. What is the condition of an electromagnetic induction?
 - a) There must be a relative motion between the coil of wire and galvanometer
 - b) There must be a relative motion between the galvanometer and a magnet
 - c) There must be a relative motion between the galvanometer and generator
 - d) There must be a relative motion between the coil of wire and a magnet
9. No force acts on a current carrying conductor when it is placed—
 - a) Perpendicular to the magnetic field
 - b) Parallel to the magnetic field
 - c) Far away from the magnetic field
 - d) Inside a magnet

16. Assertion (A): As the speed of the coil in the motor increases, there is reduction in the current flowing through it.

Reason (R): During rotation in electric motor, some induced current is produced.

- (a) (A) is incorrect and (R) is correct.
- (b) (A) is correct and (R) is incorrect.
- (c) Both (A) and (R) are correct but (R) is not the correct explanation of (A).
- (d) Both (A) and (R) are correct but (R) is the correct explanation of (A).

SHORT ANSWER TYPE QUESTIONS

1. A charged particle enters at right angle into a uniform magnetic field. What is the nature of charge particle if it experiences a force in a direction pointing vertically out of page.

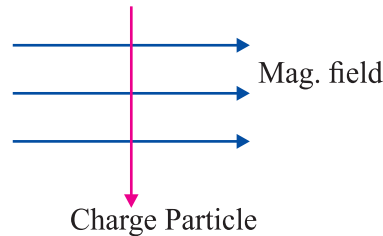

Use Fleming's Left Hand Rule

2. When does short circuit occur ?
3. Write the three ways to produce magnetic field.
4. What is overloading ?
5. Write the use of safety device used in electric circuit.
6. What is solenoid ? Where the magnetic field is uniform in solenoid ?
7. Draw the pattern of magnetic field lines due to current carrying straight conductor.
8. What is earth wire ? How it works in our domestic circuit ?
9. Draw the schematic diagram of domestic circuit. Write the colour and nature of neutral wire, live wire and earth wire.
10. What is an electromagnet ? What material are used to make electromagnet ?
Can we use steel to make electromagnet ?
11. (a) State Fleming's left hand rule.
(b) Write the principle of working of an electric motor.
(c) Explain the function of the following.
(i) Armature (ii) Brushes (iii) Split ring. (CBSE 2018)

Competency Based Questions

By nature, electricity seeks to return to ground, and in a properly functioning circuit, this means that the current flows through the established wiring circuit back to the service panel, and onward back through the utility wires. However, if the connections within the wiring loosen or break, electrical current may "leak." In this instance, the electrical current instantly seeks to flow back to ground by a shorter pathway. That pathway may very well be through flammable materials or even through a human being, which is why a short circuit presents the danger of fire or lethal shock.

The reason this happens is that these other materials offer a pathway of lesser resistance than is present in the copper wiring of a circuit.

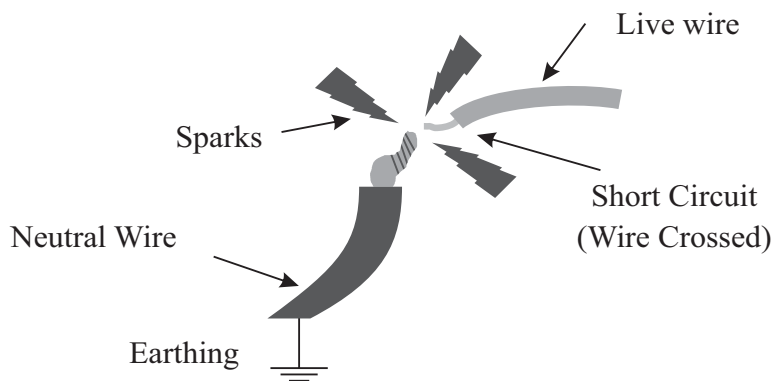

Short circuit is prevented by using a device known as fuse.

- At the time of short circuit, the current in the circuit
a) Reduces substantially b) Does not change
c) Increases heavily d) Varies continuously
- During short circuit, live wire and neutral wire come in direct contact with each other. What may be the reason behind this-
 - faulty circuit wire insulation
 - loose wire connections
 - faulty appliance wiringa) (i) and (ii) only b) (ii) and (iii) only
c) (i) and (iii) only d) (i), (ii) and (iii) all.
- What is a fuse?
 - On what principle does it work?
- To an electric device how a fuse is connected?

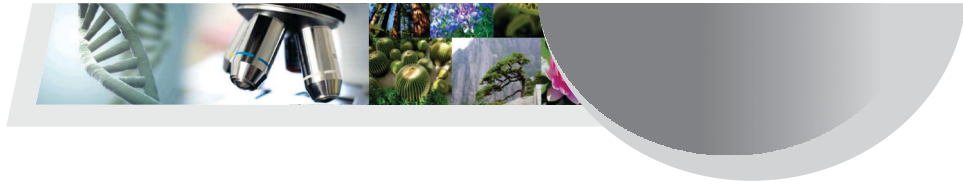

Chapter - 13

Our Environment

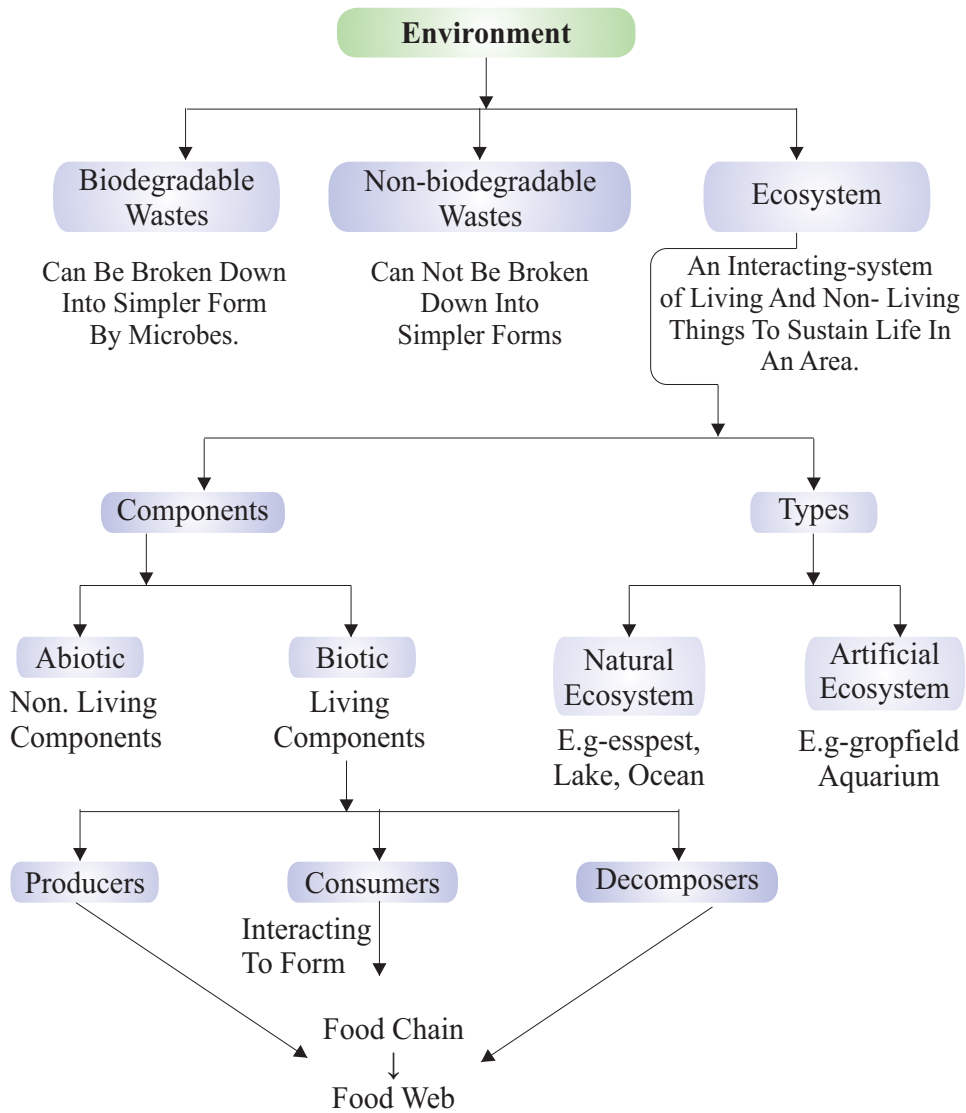

- Everything that surrounds us is environment. It includes both living (biotic) and non-living (abiotic) components.
- Interaction between these biotic and abiotic components form an ecosystem.
- In an ecosystem living components depend on each other for their food which give rise to food chains and food webs in nature.
- Human activities lead to environmental problems such as depletion of ozone layer and production of huge amount of garbage.

Ecosystem

All the interacting organisms in an area together with the non-living constituents of the environment form an ecosystem. *E.g.*, forest, pond temperature, rain, air, soil and all living organisms.

Types of ecosystem : It is of two types :

(a) Natural ecosystem : The ecosystem which exist in nature on its own. *E.g.*, forest, lake, ocean.

(b) Artificial ecosystem : Man-made ecosystems are called artificial ecosystem. *E.g.*, crop field, aquarium, garden.

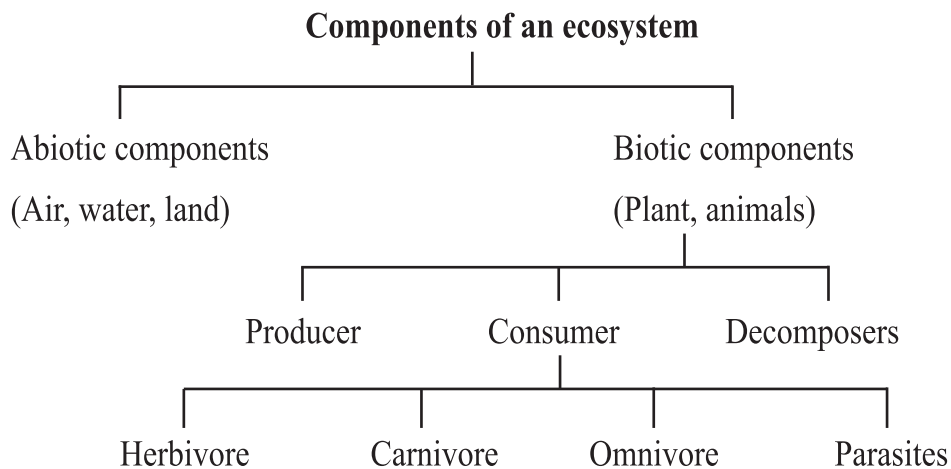

(a) **Abiotic Components** : All the non-living components such as air, water, land, light, temperature etc. form the abiotic components.

(b) **Biotic Components** : All the living components such as plants, animals, bacteria, fungi etc. form the biotic components.

On the basis of nutrition biotic components are further divided into :

Producers : All green plants and blue-green algae can produce their own food using abiotic components (photosynthesis), hence called producers.

Consumers : Include all animals which depend on producers directly or indirectly for their food.

Consumers are further divided into :

(i) **Herbivores** : Plant eaters *e.g.*, goat, deer.

(ii) **Carnivores** : Flesh eaters *e.g.*, tiger, crocodile.

(iii) **Omnivores** : Eats both plants and animals *e.g.*, human.

(iv) **Parasites** : Live on the body of host and take food from it, *e.g.* lice, cuscuta.

Decomposers : Include organisms which decompose the dead plants and animals *e.g.*, bacteria, fungi. These help in the replenishment of natural resources.

FOOD CHAIN

- Food chain is a series of organisms in which one organism eats another organism as food. *e.g.*,
Grass → Deer → Lion
- In a food chain various steps where transfer of energy takes place is called a trophic level.

Flow of energy between trophic levels

- Flow of energy in a food chain is unidirectional.
- Green plants capture 1% of sunlight and convert it into food energy.
- **10 percent law** : Only 10% of energy is transferred to the next trophic level. The remaining 90% energy is lost as heat to the environment. Some amount goes into digestion and in doing work and the rest goes towards growth and reproduction.
- An average of 10% of the food eaten is turned into its own body and made available for the next level of consumers.

- Due to this gradual decrease in energy, food chains contain 3-4 trophic levels.

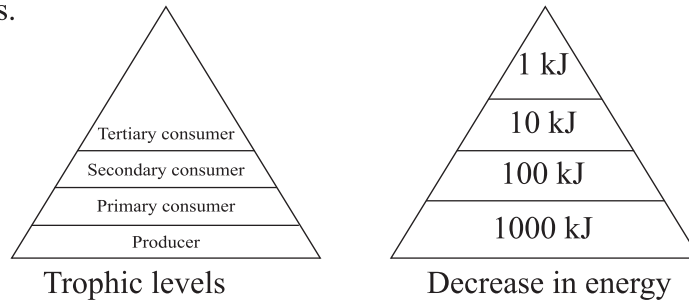

- **Biological magnification** : The concentration of harmful chemicals increases with every next trophic level in a food chain. This is called biological magnification.
- Maximum concentration of such chemicals get accumulated in human bodies as human occupy the top level in any food chain.

Food web : In nature large numbers of food chains are interconnected forming a food web.

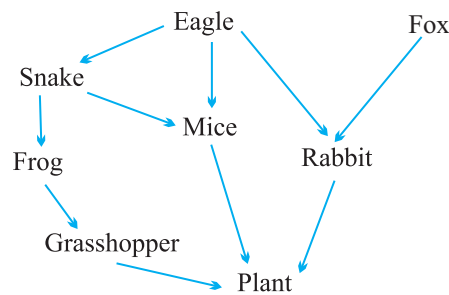

Food web

Environmental problems : Changes in the environment affect us and our activities change the environment around us. Human activities leads to pollution, deforestation etc.

Ozone layer

- Ozone layer is a protective blanket around the earth which absorbs most of the harmful UV (ultraviolet) radiations of the sunlight, thus protecting living beings from many health hazards such as skin cancer, cataract, weak immune system destruction of plants etc.
- Ozone (O₃) layer is present at higher levels of atmosphere (*i.e.*, stratosphere). It is a deadly poison at ground level.

Formation of ozone molecule

- (i) The high energy UV radiations break down the O_2 molecules into free oxygen (O) atoms.

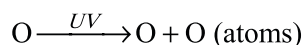

- (ii) These oxygen atoms then combine with oxygen (O_2) molecule to form the ozone molecule.

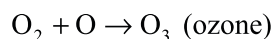

Depletion of ozone layer

- The decrease in the thickness of ozone layer over Antarctica was first observed in 1985 and was termed as ozone hole.
- This decrease was linked to excessive use of synthetic chemicals like chlorofluorocarbons (CFCs) which are used in refrigerators, ACs, fire-extinguishers, aerosols sprays etc.
- In 1987 United Nations Environment Programme (UNEP) succeeded in forging an agreement to stop CFC production at 1986 levels (KYOTO PROTOCOL) by all countries.

Garbage disposal

Garbage disposal is a main problem of today which effects our environment. Improvements in lifestyle have resulted in accumulation of large amounts of waste materials.

Garbage contains following type of materials :

- (a) **Biodegradable** : Substances which can be decomposed by the action of micro-organisms are called biodegradable wastes.

E.g., fruit and vegetable peels, cotton, jute, dung, paper, etc.

- (b) **Non-biodegradable wastes** : Substances which cannot be decomposed by the action of micro-organisms are called non-biodegradable wastes.

E.g., plastic, polythenes, metals, synthetic fibres, radioactive wastes, pesticides etc.

Micro-organisms release enzymes which decompose the materials but these enzymes are specific in their action that's why enzymes cannot decompose all the materials.

Some methods of waste disposal

- (a) **Biogas plant** : Biodegradable waste can be used in biogas plant to produce biogas and manure.
- (b) **Sewage treatment plant** : The drain water can be cleaned in sewage treatment plant before adding it to rivers.
- (c) **Land fillings** : The wastes are buried in low lying areas and are compacted by rolling with bulldozers.
- (d) **Composting** : Organic wastes are filled in a compost pit and covered with a layer of soil, after about three months garbage changes to manure.
- (e) **Recycling** : Non-biodegradable wastes are recycled to make new items.
- (f) **Reuse** : It is a conventional technique to use an item again *e.g.*, newspaper for making envelopes.
- (g) **Incineration**: It is a waste treatment process that are described as thermal treatment, it converts the waste into ash mainly it is used to transforms medical wastes.

QUESTIONS

Multiple Choice Question

1. Which pollutant released into the air during refrigeration and airconditioning is the greatest contribute to the depletion of ozone layer?
 - (a) BHC
 - (b) DDT
 - (c) CFC
 - (d) NEP
2. What percentage of sun's energy falling on the leaves of green plants is utilised by the plants in the process of photosynthesis and stored as chemical energy of food?
 - (a) 99%
 - (b) 10%
 - (c) 1%
 - (d) 20%
3. The flow of energy in an ecosystem is always
 - (a) Unidirectional
 - (b) Bidirectional
 - (c) Cyclic
 - (d) Multidirectional
4. If the energy transferred to a tertiary consumer in a food chain is 10J. How much energy was available to the primary consumer?

- (a) 100J (b) 500J
(c) 1000J (d) 5000J
5. The ten percent law is associated with
(a) Transfer of energy from various trophic to decomposers in a foodchain.
(b) Transfer of ATP energy into muscular energy
(c) Transfer of chemical energy from one organism to another
(d) Transfer of sun's energy to the organisms called producers.
6. O₂ converted into O₃ by the action of
(a) Infrared radiations (b) Ultraviolet radiations
(c) Gamma radiations (d) Cosmic radiations
7. As human being occupy the top level in any food chain, the maximum concentration of insecticides get accumulated in our bodies. This phenomeon is known as.
(a) Pollution (b) Eutrophication
(c) Biological magnification (d) None of these
8. Which one of the following is as artificial ecosystem?
(a) Pond (b) Crop field
(c) Lake (d) Forest
9. What provides the energy which then flows through a food chain?
(a) Glucose (b) Oxygen
(c) Respiration (d) Sunlight
10. Which of the following is the best method to dispose of biological wastes from hospitals?
(a) Landfill (b) recycling
(c) incineration (d) composting
11. Which of the following is biodegradable.
(a) Plastic mugs (b) Leather belts
(c) Silver foil (d) Iron nails. &

Answers

- 1.(c) 2.(c) 3.(a) 4.(c) 5.(c) 6.(b) 7.(c) 8.(b) 9.(d) 10.(c)
11.(b)

Competency Based Question:

Ultraviolet radiation could destroy the organic matter. Plants and planktons cannot thrive, both act as food for and sea animals respectively. For humans excessive exposure to ultraviolet radiation leads to higher risk of skin cancer and cataracts. It is calculated that 1% decrease in ozone layer results in a 2–5 percent increase in the occurrence of skin cancer. Other ill-effects of the reduction of protective ozone layer include increase and suppression of the immune system.

- How is ozone formed in the atmosphere?
- What damages ozone layer?
 - Chlorofluorocarbons
 - Nitric oxide
 - Free radicals of chlorine
 - All of them
- Which of the following is a global step that has been taken by the world to reduce ozone depletion?
 - KYOTO protocol
 - Gothenburg protocol
 - Montreal protocol
 - Aarhus protocol
- In which layer of the atmosphere is the ozone layer depleting?
 - Ionosphere
 - Stratosphere
 - Lithosphere
 - Thermosphere
- In the following graph shown, the magnitude of global decline in consumption of ozone-depleting substances (ODS) is shown. Study the graph and state during which period there is a sharp rise and a rapid decline seen in their consumption.
 - During 1986–87 and 2000–2005
 - During 1987–88 and 2016–2017
 - During 2000–2001 and 2010
 - During 1990–91 and 2016

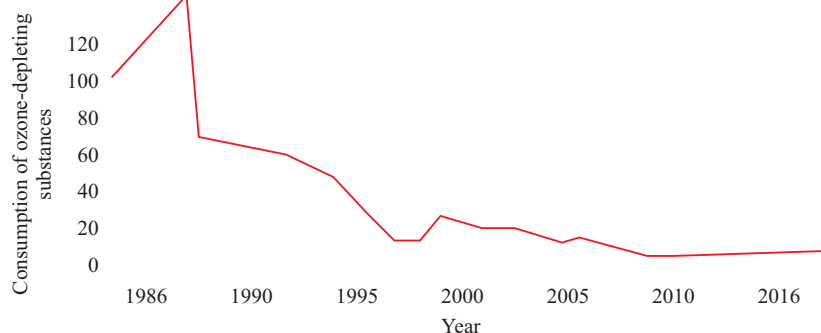

4. CFC Causes depletion of
 - (a) Ozone
 - (b) Oxygen
 - (c) Nitrogen
 - (d) None of these
5. The concentration of harmful chemicals increases with energy next trophic level in a food chain. Name this process.
6. Name two materials which can be recycled.
7. Define trophic level.
8. What is the full form of CFC and UNEP?
9. Name the radiations that are absorbed by the ozone layer.
10. Which will get more energy secondary consumers or tertiary consumers?
11. What is the functional unit of environment.
12. Which of the following are not biodegradable.
Wool, Glass, Silver foil, Leather
13. Name any two parasites
14. What is KYOTO protocol?

Answers

1. Abiotic- Soil air, water temperature Biotic- Plants, animals
2. Grass → grasshopper → frog → snakes → eagle
3. 3.10%
4. a
5. Biological magnification
6. Paper, Plastic

2 Marks

1. Explain how does making of Kulhads affects our environment?
(CBSE 2013)
2. What will happen if all the phytoplanktons are eliminated from pond?
3. State two differences between a consumer and producer.
4. Draw the line diagram showing flow of energy in an ecosystem.
5. Define a food web. State its significance for ecosystem.
6. What are phytoplanktons.
7. Name two natural ecosystem.

Hints to Long Answer Type Questions

1. Methods for Garbage disposal :

Land filling

Compositing

Recycling

Resuse

Biogas plant

Sewage treatment plant

2. Food Chain : Transfer of energy through various trophic level in an ecosystem.

Characteristics : (i) Unidirectional

(ii) 1% of total solar energy is absorbed by plants.

(iii) Transfer of energy through various trophic level is in accordance with 10 percent law.

3. Bio magnification

CBSE Question Paper 2022-23
Class X
Subject - Science

SECTION-A

(Multiple Choice Questions)

1. When aqueous solutions of potassium iodide and lead nitrate are mixed, an insoluble substance separates out. The chemical equation for the reaction involved is : 1
- (a) $KI + PbNO_3 \rightarrow PbI + KNO_3$
- (b) $2KI + Pb(NO_3)_2 \rightarrow PbI_2 + 2KNO_3$
- (c) $KI + Pb(NO_3)_2 \rightarrow PbI + KNO_3$
- (d) $KI + PbNO_3 \rightarrow PbI_2 + KNO_3$
2. When Sodium bicarbonate reacts with dilute hydrochloric acid, the gas evolved is: 1
- (a) Hydrogen; it gives pop sound with burning match stick.
- (b) Hydrogen; it turns lime water milky.
- (c) Carbon dioxide; it turns lime water milky.
- (d) Carbon dioxide; it blows off a burning match stick with a pop sound.
3. Acid present in tomato is : 1
- (a) Methanoic acid
- (b) Acetic acid
- (c) Lactic acid
- (d) Oxalic acid

4. A metal ribbon 'X' burns in oxygen with a dazzling white flame forming a white ash 'Y'. The correct description of X, Y and the type of reaction is : 1

- (a) X = Ca; Y = CaO; Type of reaction = Decomposition
- (b) X = Mg; Y = MgO; Type of reaction = Combination
- (c) X = Al; Y = Al₂O₃; Type of reaction = Thermal decomposition
- (d) X = Zn; Y = ZnO; Type of reaction = Endothermic

5. The name of the salt used to remove permanent hardness of water is : 1

- (a) Sodium hydrogen carbonate (NaHCO₃)
- (b) Sodium chloride (NaCl)
- (c) Sodium carbonate decahydrate (Na₂CO₃ · 10H₂O)
- (d) Calcium sulphate hemihydrate (CaSO₄ · $\frac{1}{2}$ H₂O)

6. The electron dot structure of chlorine molecule is : 1

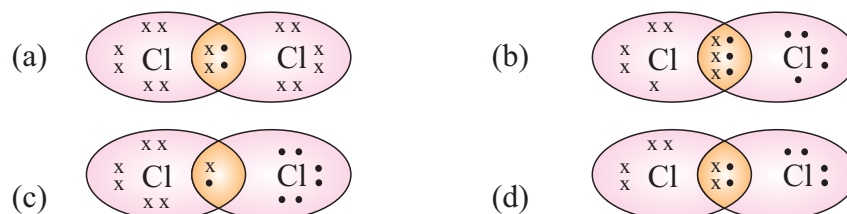

7. Sodium hydroxide is termed an alkali while Ferric hydroxide is not because : 1

- (a) Sodium hydroxide is a strong base, while Ferric hydroxide is a weak base.

- (b) Sodium hydroxide is a base which is soluble in water while Ferric hydroxide is also a base but it is not soluble in water.
- (c) Sodium hydroxide is a strong base while Ferric hydroxide is a strong acid.
- (d) Sodium hydroxide and Ferric hydroxide both are strong base but the solubility of Sodium hydroxide in water is comparatively higher than that of Ferric hydroxide.
8. Opening and closing of stomata is due to : 1
- (a) High pressure of gases inside the cells.
- (b) Movement of water in and out of the guard cells.
- (c) Stimulus of light in the guard cells.
- (d) Diffusion of CO_2 in and out of the guard cells.
9. Water in the root enters due to : 1
- (a) the function of the root to absorb water.
- (b) difference in the concentration of ions between the root and the soil.
- (c) excess water present in the soil.
- (d) diffusion of water in the roots.
10. Which one of the given statements is incorrect : 1
- (a) DNA has the complete information for a particular characteristic.
- (b) DNA is the molecule responsible for the inheritance of characters from parents to offsprings.

- (c) Change in information will produce a different protein.
- (d) Characteristics will remain the same even if protein changes.

11. Sensory nerve of a reflex arc carries information from the receptor cells to the: 1

- (a) spinal cord
- (b) brain
- (c) muscles of the effector organ
- (d) bones of the receptor organ

12. A cross between pea plant with white flowers (vv) and pea plant with violet flowers (VV) resulted in F₂ progeny in which ratio of violet (VV) and white (vv) flowers will be: 1

- (a) 1:1
- (b) 2:1
- (c) 3:1
- (d) 1:3

13. The correct pattern of magnetic field lines of the field produced by a current carrying circular loop is: 1

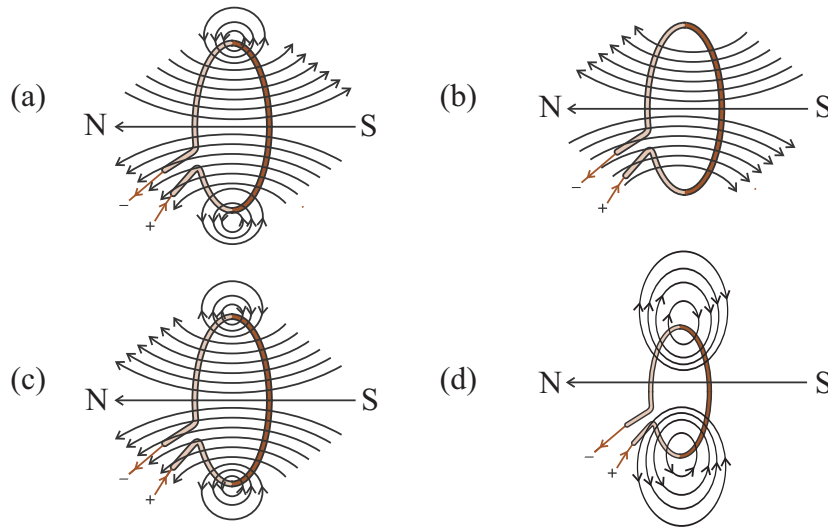

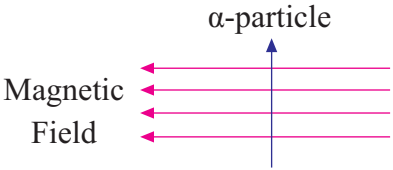
14. Two LED bulbs of 12W and 6W are connected in series. If the current through 12W bulb is 0.06A the current through 6W bulb will be: 1
- (a) 0.04A (b) 0.06A
(c) 0.08A (d) 0.12A
15. An alpha particle enters a uniform magnetic field as shown. The direction of motion of the alpha particle is : 1
- (a) towards right
(b) towards left
(c) into the page
(d) out of the page
- 
16. The resistance of a resistor is reduced to half of its initial value. If other parameters of the electrical circuit remain unaltered, the amount of heat produced in the resistor will become : 1
- (a) four times
(b) two times
(c) half
(d) one fourth

Q.No. 17 to 20 are Assertion - Reasoning based questions.

These consist of two statements Assertion (A) and Reason (R). Answer these questions selecting the appropriate option given below.

- (a) Both (A) and (R) are true and (R) is the correct explanation of (A).
(b) Both (A) and (R) are true but (R) is not the correct explanation of (A).

- (c) (A) is true but (R) is false.
- (d) (A) is false but (R) is true.
17. **Assertion (A):** In humans, if gene (B) is responsible for black eyes and gene (b) is responsible for brown eyes, then the colour of eyes of the progeny having gene combination Bb, bb or BB will be black only. 1
- Reason (R):** The black colour of the eyes is a dominant trait. 1
18. **Assertion (A):** Reaction of Quicklime with water is an exothermic reaction.
- Reason (R):** Quicklime reacts vigorously with water releasing a large amount of heat. 1
19. **Assertion (A):** A current carrying straight conductor experiences a force when placed perpendicular to the direction of magnetic field.
- Reason (R):** The net charge on a current carrying conductor is always zero. 1
20. **Assertion (A):** The inner walls of the small intestine have finger like projections called villi which are rich in blood.
- Reason (R):** These villi have a large surface area to help the small intestine in completing the digestion of food.

SECTION - B

(Very Short Answer Questions)

21. Name a plant hormone responsible for bending of a shoot of a plant when it is exposed to unidirectional light. How does it promote phototropism? 2
22. (A) A student took a small amount of copper oxide in a conical flask and added dilute hydrochloric acid to it with constant stirring. He observed a change in colour of the solution. 2
- (i) Write the name of the compound formed and its colour.
- (ii) Write a balanced chemical equation for the reaction involved.

OR

- (B) The industrial process used for the manufacture of caustic soda involves electrolysis of an aqueous solution of compound 'X'. In this process, two gases 'Y' and 'Z' are liberated. 'Y' is liberated at cathode and 'Z', which is liberated at anode, on treatment with dry slaked lime forms a compound 'B'. Name X, Y, Z and B. 2
23. Two green plants are kept separately in oxygen free containers, one in the dark and other in sunlight. It was observed that plant kept in dark could not survive longer. Give reason for this observation. 2
24. What is the other name of 'tissue fluid'? Write its two functions. 2
25. "Although gardens are created by man but they are considered to be an ecosystem." Justify this statement. 2

26. (A) Observe the following diagram and answer the questions following it: 2

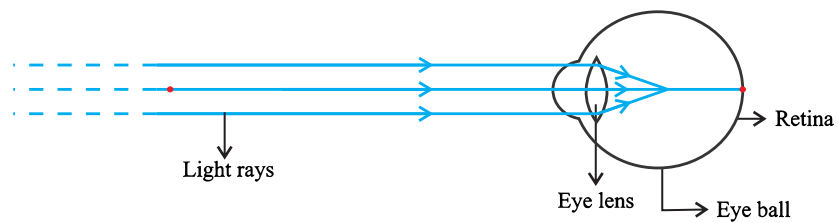

- (i) Identify the defect of vision shown.
- (ii) List its two causes.
- (iii) Name the type of lens used for the correction of this defect.

OR

- (B) The colour of clear sky from the earth appears blue but from the space it appears black. Why? 2

SECTION-C

(Short Answer Questions)

27. Consider the following salts: 3
- (i) YCl
 - (ii) NH_4X
 - (iii) ZCO_3
- (a) What would be the pH of the salt solution if in YCl, Y is sodium? Give reason for your answer.
- (b) If in salt NH_4X , X is nitrate, then its solution will give what colour with universal indicator? Why?
- (c) What would be the change in colour in blue litmus solution if ZCO_3 is added to it and Z is potassium?
28. (i) While electrolysing water before passing the current some drops of an acid are added. Why? Name the gases liberated at cathode and anode. Write the relationship between the volume of gas collected at anode and the volume of gas collected at cathode. 3
- (ii) What is observed when silver chloride is exposed to sunlight? Give the type of reaction involved.
29. The magnification produced when an object is placed at a distance of 20 cm from a spherical mirror is $+1/2$. Where should the object be placed to reduce the magnification to $+1/3$. 3

30. (A) (i) How does Paramecium obtain its food? 3
- (ii) List the role of each of the following in our digestive system:
- (a) Hydrochloric acid
 - (b) Trypsin
 - (c) Muscular walls of stomach
 - (d) Salivary amylase

OR

- (B) (i) What is double circulation? 3
- (ii) Why is the separation of the right side and the left side of the heart useful? How does it help birds and mammals?
31. (A) (i) Why is an alternating current (A.C.) considered to be 3
advantageous over direct current (D.C.) for the long distance transmission of electric power?
- (ii) How is the type of current used in household supply different from the one given by a battery of dry cells?
- (iii) How does an electric fuse prevent the electric circuit and the appliances from a possible damage due to short circuiting or overloading.

OR

- (B) For the current carrying solenoid as shown, draw magnetic field lines and give reason to explain that out of the three points A, B and C, at which point the field strength is maximum and at which point it is minimum? 3

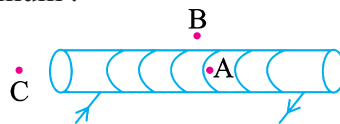

32. Write one difference between biodegradable and non-biodegradable wastes. List two impacts of each type of the accumulated waste on environment if not disposed off properly. 3

33. (A) Define the term dispersion of white light. State the colour which bends (i) the most, (ii) the least while passing through a glass prism. Draw a diagram to show the dispersion of white light. 3

OR

(B) What is a rainbow? Draw a labelled diagram to show its formation. 3

SECTION-D

(Long Answer Questions)

34. (i) Name and explain the two modes of asexual reproduction observed in hydra. 5
- (ii) What is vegetative propagation? List two advantages of using this technique.
35. (i) How is electric current related to the potential difference across the terminals of a conductor? 5
- Draw a labelled circuit diagram to verify this relationship.
- (ii) Why should an ammeter have low resistance?
- (iii) Two V - I graphs A and B for series and parallel combinations of two resistors are as shown. Giving reason state which graph shows (a) series, (b) parallel combination of the resistors.

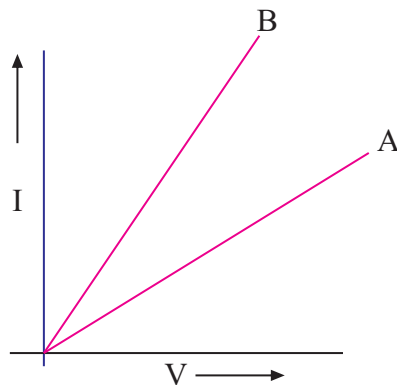

36. (A) Write the chemical equation for the following: 5

- (i) Combustion of methane
- (ii) Oxidation of ethanol
- (iii) Hydrogenation of ethene
- (iv) Esterification Reaction
- (v) Saponification Reaction

OR

(B) (i) Draw two structural isomers of butane. 5

- (ii) Draw the structures of propanol and propanone.
- (iii) Name the third homologue of :
 - (a) alcohols
 - (b) aldehydes

(iv) Name the following:

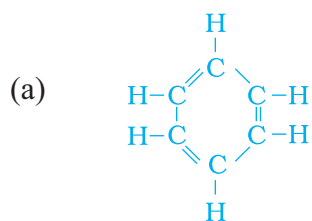

(b) $\text{CH}_3\text{-CH}_2\text{CH=CH}_2$

(v) Show the covalent bond formation in nitrogen molecule.

SECTION-E

(Source Based/Case Based Questions)

37. The most obvious outcome of the reproductive process is the generation of individuals of similar design, but in sexual reproduction they may not be exactly alike. The resemblances as well as differences are marked. The rules of heredity determine the process by which traits and characteristics are reliably inherited. Many experiments have been done to study the rules of inheritance. 4

(i) Why an offspring of human being is not a true copy of his parents in sexual reproduction? 1

(ii) While performing experiments on inheritance in plants, what is the difference between F_1 and F_2 generation? 1

(iii) (A) Why do we say that variations are useful for the survival of a species over time? 2

OR

(iii) (B) Study Mendel's cross between two plants with a pair of contrasting characters. 2

RRYY X rryy

Round Yellow Wrinkled Green

He observed 4 types of combinations in F_2 generation. Which of these were new combinations? Why do new features which are not present in the parents, appear in F_2 generation?

38. The ability of a medium to refract light is expressed in terms of its optical density. Optical density has a definite connotation. It is not the same as mass density. On comparing two media, the one with the 4

large refractive index is optically denser medium than the other. The other medium with a lower refractive index is optically rarer. Also the speed of light through a given medium is inversely proportional to its optical density.

- (i) Determine the speed of light in diamond if the refractive index of diamond with respect to vacuum is 2.42. Speed of light in vacuum is 3×10^8 m/s. 1
- (ii) Refractive indices of glass, water and carbon disulphide are 1.5, 1.33 and 1.62 respectively. If a ray of light is incident in these media at the same angle (say θ), then write the increasing order of the angle of refraction in these media. 1
- (iii) (A) The speed of light in glass is 2×10^8 m/s and in water is 2.25×10^8 m/s. 2
- (a) Which one of the two is optically denser and why?
- (b) A ray of light is incident normally at the water-glass interface when it enters a thick glass container filled with water. What will happen to the path of the ray after entering the glass? Give reason.

OR

- (iii) (B) The absolute refractive indices of water and glass are $\frac{4}{3}$ and $\frac{3}{2}$ respectively. If the speed of light in glass is 2×10^8 m/s, find the speed of light in (i) vacuum and (ii) water. 2

39. The melting points and boiling points of some ionic compounds are given below: 4

Compound	Melting Point (K)	Boiling Point (K)
NaCl	1074	1686
LiCl	887	1600
CaCl ₂	1045	1900
CaO	2850	3120
MgCl ₂	981	1685

These compounds are termed ionic because they are formed by the transfer of electrons from a metal to a non-metal. The electron transfer in such compounds is controlled by the electronic configuration of the elements involved. Every element tends to attain a completely filled valence shell of its nearest noble gas or a stable octet.

- (i) Show the electron transfer in the formation of magnesium chloride. 1
- (ii) List two properties of ionic compounds other than their high melting and boiling points. 1
- (iii) (A) While forming an ionic compound say sodium chloride how does sodium atom attain its stable configuration? 2

OR

- (iii) (B) **Give reasons:** 2
- (i) Why do ionic compounds in the solid state not conduct electricity?
- (ii) What happens at the cathode when electricity is passed through an aqueous solution of sodium chloride?

