

DIRECTORATE OF EDUCATION
Govt. of NCT, Delhi

SUPPORT MATERIAL
2023-2024

Class : XI

PHYSICS

Under the Guidance of

Shri Ashok Kumar

Secretary (Education)

Shri Himanshu Gupta

Director (Education)

Dr. Rita Sharma

Addl. DE (School & Exam.)

Coordinators

Mr. Sanjay Subhas Kumar
DDE (Exam)

Mrs. Ritu Singhal
OSD (Exam)

Mr. Raj Kumar
OSD (Exam)

Mr. Krishan Kumar
OSD (Exam)

Production Team
Anil Kumar Sharma

Published at Delhi Bureau of Text Books, 25/2, Institutional Area, Pankha Road, New Delhi-58 by **Rajesh Kumar**, Secretary, Delhi Bureau of Text Books and Printed at: Supreme Offset, Greater Noida, U.P.

अशोक कुमार, भा.प्र.से
सचिव (शिक्षा)

ASHOK KUMAR, IAS
Secretary (Education)



राष्ट्रीय राजधानी क्षेत्र, दिल्ली सरकार

पुराना सचिवालय, दिल्ली-110054

दूरभाष : 23890187 टेलीफैक्स: 23890119

Government of National Capital Territory of Delhi

Old Secretariat, Delhi-110054

Phone : 23890187, Telefax : 23890119

e-mail : secyedu@nic.in

D.O. NO. : DE.5/228/Exam/Message/SM

Dated : 24.11.2023 / 2018/1095

Message

"Children are like wet cement, whatever falls on them makes an impression."

Haim Ginott

Embracing the essence of this quote, the Directorate of Education, GNCT of Delhi is unwavering in its commitment to its core mission of delivering high-quality education to all its students. With this objective in mind, DoE annually develops support materials meticulously tailored to suit the learning needs of students from classes IX to XII.

Every year, our expert faculty members shoulder the responsibility of consistently reviewing and updating the Support Material to synchronize it with the latest changes introduced by CBSE. This continuous effort is aimed at empowering students with innovative approaches and techniques, fostering their problem-solving skills and critical thinking abilities. I am confident that this year will be no exception, and the Support Material will greatly contribute to our students' academic success.

The support material is the result of unwavering dedication of our team of subject experts. The Support Material has been specially curated for our students, with the belief that its thoughtful and intelligent utilization will undoubtedly elevate the standards of learning and will continue to empower our students to excel in their examinations.

I wish to congratulate the entire team for their invaluable contribution in creating a highly beneficial and practical Support Material for our students.

I extend my best wishes to all our students for a promising and bright future.

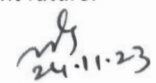
(Ashok Kumar)

HIMANSHU GUPTA, IAS
Director, Education & Sports

No. PS/DE/2023/349
Date: 29/11/2023



Directorate of Education
Govt. of NCT of Delhi
Room No. 12, Civil Lines
Near Vidhan Sabha,
Delhi-110054
Ph.: 011-23890172
E-mail: diredu@nic.in

MESSAGE

It brings me immense pleasure to present the support material for students of classes IX to XII, meticulously crafted by our dedicated subject experts. Directorate of Education is committed to empower educators and students alike by providing these resources free of cost for students of all government and government aided schools of Delhi.

The support material is an appreciable effort to align the content with the latest CBSE patterns. It has been carefully designed as a resource to facilitate the understanding, acquisition and practice of essential skills and competencies outlined in the curriculum.

The core of this support material lies in providing a framework for adopting an analysis-based approach to learning and problem-solving. It aims to prompt educators to reflect on their teaching methodologies and create an interactive pathway between the child and the text.

In the profound words of Dr A.P.J. Abdul Kalam, **“Educationists should build the capacities of the spirit of inquiry, creativity, entrepreneurial and moral leadership among students and become their role model.”**

The journey of education is ongoing; it's the process, not just the outcome, which shapes us. This support material endeavours to be that catalyst of change for each student of Directorate of Education.

Let us embark on this transformative journey together, ensuring that every student feels equipped not only with the knowledge but also, with the skills and mindset to thrive in the 21st century.

I wish you all the best for all your future endeavours.

(HIMANSHU GUPTA)

Dr. RITA SHARMA
Additional Director of Education
(School/Exam)



सत्यमेव जयते

Govt. of NCT of Delhi
Directorate of Education
Old Secretariat, Delhi-110054
Ph.: 23890185

D.O. No. DE:5/22.8/Exam/Mexay/SH/
2013/1096
Dated:24.11.2023.....

MESSAGE

The persistent efforts of the Directorate in making the course material more accessible and student-friendly are evident in the conscientious preparation of the Support Material. Our team consistently adapts to the evolving educational landscape, ensuring that the Support Material for the various subjects of classes 9 to 12 align with the latest CBSE guidelines and syllabi prescribed for the annual examinations.

The Support Material encapsulates crucial subject-specific points and facts, tailored to suit the students, all presented in a lucid language. It is our firm belief that these resources will significantly augment the academic prowess of our students, empowering them to excel in their upcoming examinations.

I extend my heartfelt congratulations to the diligent officials and teachers whose dedication and expertise have played a pivotal role in crafting this invaluable content/resource.

I convey my best wishes to all our students for a future brimming with success. Remember, every page you read is a step towards an enlightened tomorrow.

Rita Sharma

(Dr Rita Sharma)

DIRECTORATE OF EDUCATION
Govt. of NCT, Delhi

SUPPORT MATERIAL
2023-2024

PHYSICS

Class : XI

NOT FOR SALE

PUBLISHED BY : DELHI BUREAU OF TEXTBOOKS

भारत का संविधान

उद्देशिका

हम, भारत के लोग, भारत को एक ¹[संपूर्ण प्रभुत्व-संपन्न समाजवादी पंथनिरपेक्ष लोकतंत्रात्मक गणराज्य] बनाने के लिए, तथा उसके समस्त नागरिकों को :

सामाजिक, आर्थिक और राजनैतिक न्याय,

विचार, अभिव्यक्ति, विश्वास, धर्म

और उपासना की स्वतंत्रता,

प्रतिष्ठा और अवसर की समता

प्राप्त कराने के लिए,

तथा उन सब में

व्यक्ति की गरिमा और ²[राष्ट्र की एकता

और अखंडता] सुनिश्चित करने वाली बंधुता

बढ़ाने के लिए

दृढसंकल्प होकर अपनी इस संविधान सभा में आज तारीख 26 नवंबर, 1949 ई. को एतद्वारा इस संविधान को अंगीकृत, अधिनियमित और आत्मार्पित करते हैं।

1. संविधान (बयालीसवां संशोधन) अधिनियम, 1976 की धारा 2 द्वारा (3.1.1977 से) "प्रभुत्व-संपन्न लोकतंत्रात्मक गणराज्य" के स्थान पर प्रतिस्थापित।
2. संविधान (बयालीसवां संशोधन) अधिनियम, 1976 की धारा 2 द्वारा (3.1.1977 से) "राष्ट्र की एकता" के स्थान पर प्रतिस्थापित।

THE CONSTITUTION OF INDIA

PREAMBLE

WE, THE PEOPLE OF INDIA, having solemnly resolved to constitute India into a ¹**[SOVEREIGN SOCIALIST SECULAR DEMOCRATIC REPUBLIC]** and to secure to all its citizens :

JUSTICE, social, economic and political;

LIBERTY of thought, expression, belief, faith and worship;

EQUALITY of status and of opportunity; and to promote among them all

FRATERNITY assuring the dignity of the individual and the ²[unity and integrity of the Nation];

IN OUR CONSTITUENT ASSEMBLY this twenty-sixth day of November, 1949 do **HEREBY ADOPT, ENACT AND GIVE TO OURSELVES THIS CONSTITUTION.**

1. Subs. by the Constitution (Forty-second Amendment) Act, 1976, Sec.2, for "Sovereign Democratic Republic" (w.e.f. 3.1.1977)
2. Subs. by the Constitution (Forty-second Amendment) Act, 1976, Sec.2, for "Unity of the Nation" (w.e.f. 3.1.1977)

भारत का संविधान

भाग 4क

नागरिकों के मूल कर्तव्य

अनुच्छेद 51 क

मूल कर्तव्य - भारत के प्रत्येक नागरिक का यह कर्तव्य होगा कि वह -

- (क) संविधान का पालन करे और उसके आदर्शों, संस्थाओं, राष्ट्रध्वज और राष्ट्रगान का आदर करे;
- (ख) स्वतंत्रता के लिए हमारे राष्ट्रीय आंदोलन को प्रेरित करने वाले उच्च आदर्शों को हृदय में संजोए रखे और उनका पालन करे;
- (ग) भारत की संप्रभुता, एकता और अखंडता की रक्षा करे और उसे अक्षुण्ण बनाए रखे;
- (घ) देश की रक्षा करे और आह्वान किए जाने पर राष्ट्र की सेवा करे;
- (ङ) भारत के सभी लोगों में समरसता और समान भ्रातृत्व की भावना का निर्माण करे जो धर्म, भाषा और प्रदेश या वर्ग पर आधारित सभी भेदभावों से परे हो, ऐसी प्रथाओं का त्याग करे जो महिलाओं के सम्मान के विरुद्ध हों;
- (च) हमारी सामासिक संस्कृति की गौरवशाली परंपरा का महत्त्व समझे और उसका परिरक्षण करे;
- (छ) प्राकृतिक पर्यावरण की, जिसके अंतर्गत वन, झील, नदी और वन्य जीव हैं, रक्षा करे और उसका संवर्धन करे तथा प्राणिमात्र के प्रति दयाभाव रखे;
- (ज) वैज्ञानिक दृष्टिकोण, मानववाद और ज्ञानार्जन तथा सुधार की भावना का विकास करे;
- (झ) सार्वजनिक संपत्ति को सुरक्षित रखे और हिंसा से दूर रहे;
- (ञ) व्यक्तिगत और सामूहिक गतिविधियों के सभी क्षेत्रों में उत्कर्ष की ओर बढ़ने का सतत् प्रयास करे, जिससे राष्ट्र निरंतर बढ़ते हुए प्रयत्न और उपलब्धि की नई ऊँचाइयों को छू सके; और
- (ट) यदि माता-पिता या संरक्षक हैं, छह वर्ष से चौदह वर्ष तक की आयु वाले अपने, यथास्थिति, बालक या प्रतिपाल्य को शिक्षा के अवसर प्रदान करे।



Constitution of India

Part IV A (Article 51 A)

Fundamental Duties

It shall be the duty of every citizen of India —

- (a) to abide by the Constitution and respect its ideals and institutions, the National Flag and the National Anthem;
- (b) to cherish and follow the noble ideals which inspired our national struggle for freedom;
- (c) to uphold and protect the sovereignty, unity and integrity of India;
- (d) to defend the country and render national service when called upon to do so;
- (e) to promote harmony and the spirit of common brotherhood amongst all the people of India transcending religious, linguistic and regional or sectional diversities; to renounce practices derogatory to the dignity of women;
- (f) to value and preserve the rich heritage of our composite culture;
- (g) to protect and improve the natural environment including forests, lakes, rivers, wildlife and to have compassion for living creatures;
- (h) to develop the scientific temper, humanism and the spirit of inquiry and reform;
- (i) to safeguard public property and to abjure violence;
- (j) to strive towards excellence in all spheres of individual and collective activity so that the nation constantly rises to higher levels of endeavour and achievement;
- * (k) who is a parent or guardian, to provide opportunities for education to his child or, as the case may be, ward between the age of six and fourteen years.

Note: The Article 51A containing Fundamental Duties was inserted by the Constitution (42nd Amendment) Act, 1976 (with effect from 3 January 1977).

* (k) was inserted by the Constitution (86th Amendment) Act, 2002 (with effect from 1 April 2010).



PHYSICS

CLASS-XI

CONTRIBUTORS

S.No.	Name	Designation	School
1.	Jile Singh (Group Leader)	Vice Principal	SBV No. 3, Mandawali, Delhi-110092
2.	Devinder Kumar	Lecturer Physics	SBV A-Block, Vikas Puri, New Delhi-110018
3.	Deepti Gupta	Lecturer Physics	SKV, Timarpur, Delhi-110054
4.	Joginder	Lecturer Physics	RPVV, Pocket-5 Narela, Delhi-110040
5.	Krishan Kumar	Lecturer Physics	RPVV, Phase-II, Sector-21 Rohini, Delhi-110086

CONTENTS

Unit	Chapter	Page
1.	Dimensions and Measurement	1 – 31
2.	Kinematics	32 – 86
3.	Laws of motion	87 – 130
4.	Work, Energy and Power	131 – 167
5.	Motion of system of particles and Rigid Body	168 – 204
6.	Gravitation	205 – 244
7.	Properties of Bulk Matter	245 – 306
8.	Thermodynamics	307 – 350
9.	Behaviour of Perfect Gases and Kinetic Theory of Gases	351 – 372
10.	Oscillations and Waves	373 – 428
	Practice question paper	429 – 469

PHYSICS (Code No. 042)

COURSE STRUCTURE

Class XI, 2023-24 (Theory)

Time: 3 hrs.

Max. Marks: 70

		No. of Periods	Marks
Unit-I	Physical World and Measurement	08	23
	Chapter-2 : Units and Measurements		
Unit-II	Kinematics	24	17
	Chapter-3: Motion in a Straight Line		
	Chapter-4: Motion in a Plane		
Unit-III	Laws of Motion	14	20
	Chapter-5: Laws of Motion		
Unit-IV	Work, Energy and Power	14	17
	Chapter-6: Work, Energy and Power		
Unit-V	Motion of System of Particles & Rigid Body	18	17
	Chapter-7: System of Particles and Rotational Motion		
Unit-VI	Gravitation	12	20
	Chapter-8: Gravitation		
Unit-VII	Properties of Bulk Matter	24	20
	Chapter-9: Mechanical Properties of Solids		
	Chapter-10 : Mechanical Properties of Fluids		
	Chapter-11 : Thermal Properties of Matter		
Unit-VIII	Thermodynamics	12	20
	Chapter-12: Thermodynamics		
Unit-IX	Behaviour of Perfect Gases and Kinetic Theory of Gases	08	10
	Chapter-13: Kinetic Theory		
Unit-X	Oscillation and Waves	26	10
	Chapter-14: Oscillations		
	Chapter-15: Waves		
	Total	160	70

SYLLABUS

CLASS-XI

2022–23

Unit-I : Physical World and Measurement **08 Periods**

Chapter-2: Units and Measurements

Need for measurement: Units of measurement; systems of units; SI units, fundamental and derived units. significant figures. Dimensions of physical quantities, dimensional analysis and its applications.

Unit-II : Kinematics **24 Periods**

Chapter-3: Motion in a Straight Line

Frame of reference, Motion in a straight line, Elementary concepts of differentiation and integration for describing motion, uniform and non- uniform motion, and instantaneous velocity, uniformly accelerated motion, velocity - time and position-time graphs. Relations for uniformly accelerated motion (graphical treatment).

Chapter-4: Motion in a Plane

Scalar and vector quantities; position and displacement vectors, general vectors and their notations; equality of vectors, multiplication of vectors by a real number; addition and subtraction of vectors, Unit vector, resolution of a vector in a plane, rectangular components, Scalar and Vector product of vectors.

Motion in a plane, cases of uniform velocity and uniform acceleration-projectile motion, uniform circular motion.

Unit-III : Laws of Motion **14 Periods**

Chapter-5: Laws of Motion

Intuitive concept of force, Inertia, Newton's first law of motion; momentum and Newton's second law of motion; impulse; Newton's third law of motion. Law of conservation of linear momentum and its applications.

Equilibrium of concurrent forces, Static and kinetic friction, laws of friction, rolling friction, lubrication. Dynamics of uniform circular motion: Centripetal force, examples of circular motion (vehicle on a level circular road, vehicle on a banked road).

Unit-IV : Work, Energy and Power **14 Periods**

Chapter-6: Work, Energy and Power

Work done by a constant force and a variable force; kinetic energy, work- energy theorem, power.

Notion of potential energy, potential energy of a spring, conservative forces: non-conservative forces, motion in a vertical circle; elastic and inelastic collisions in one and two dimensions.

Unit-V : Motion of System of Particles and Rigid Body **18 Periods**

Chapter-7: System of Particles and Rotational Motion

Centre of mass of a two-particle system, momentum conservation and Centre of mass motion. Centre of mass of a rigid body; centre of mass of a uniform rod.

Moment of a force, torque, angular momentum, law of conservation of angular momentum and its applications.

Equilibrium of rigid bodies, rigid body rotation and equations of rotational motion, comparison of linear and rotational motions.

Moment of inertia, radius of gyration, values of moments of inertia for simple geometrical objects (no derivation).

Unit-VI : Gravitation **12 Periods**

Chapter-8: Gravitation

Kepler's laws of planetary motion, universal law of gravitation. Acceleration due to gravity and its variation with altitude and depth. Gravitational potential energy and gravitational potential, escape speed orbital velocity of a satellite.

Unit-VII : Properties of Bulk Matter **24 Periods**

Chapter-9: Mechanical Properties of Solids

Elasticity, Stress-strain relationship, Hooke's law, Young's modulus, bulk modulus, shear modulus of rigidity (qualitative idea only). Poisson's ratio; elastic energy.

Chapter-10: Mechanical Properties of Fluids

Pressure due to a fluid column; Pascal's law and its applications (hydraulic lift and hydraulic brakes), effect of gravity on fluid pressure. Viscosity, Stokes' law, terminal velocity, streamline and

turbulent flow, critical velocity, Bernoulli's theorem and its simple applications.

Surface energy and surface tension, angle of contact, excess of pressure across a curved surface, application of surface tension ideas to drops, bubbles and capillary rise.

Chapter-11: Thermal Properties of Matter

Heat, temperature, thermal expansion; thermal expansion of solids, liquids and gases, anomalous expansion of water; specific heat capacity; Cp. Cv - calorimetry; change of state- latent heat capacity.

Heat transfer-conduction, convection and radiation, thermal conductivity. qualitative ideas of Blackbody radiation, Wein's displacement Law, Stefan's law.

Unit-VIII :Thermodynamics

12 Periods

Chapter-12: Thermodynamics

Thermal equilibrium and definition of temperature, zeroth law of thermodynamics, heat, work and internal energy. First law of thermodynamics.

Second law of thermodynamics: gaseous state of matter, change of condition of gaseous state -isothermal, adiabatic, reversible, irreversible and cyclic processes.

Unit-IX : Behaviour of Perfect Gases and Kinetic Theory of Gases

08 Periods

Chapter-13: Kinetic Theory

Equation of state of a perfect gas, work done in compressing a gas

Kinetic theory of gases assumptions, concept of pressure. Kinetic interpretation of temperature; rms speed of gas molecules; degrees of freedom, law of equi-partition of energy (statement only) and application to specific heat capacities of gases; concept of mean free path, Avogadro's number.

Unit-X : Oscillations and Waves

26 Periods

Chapter-14: Oscillations

Periodic motion-time period, frequency, displacement as a function of time, periodic functions and their applications.

Simple harmonic motion (S.H.M) and its equations of motion; phase; oscillations of a loaded spring- restoring force and force constant,

energy in S.H.M. Kinetic and potential energies; simple pendulum derivation of expression for its time period.

Chapter-15: Waves

Wave motion: Transverse and longitudinal waves, speed of travelling wave. displacement relation for a progressive wave, principle of superposition of waves, reflection of waves, standing waves in strings and organ pipes. fundamental mode and harmonics, Beats.



Question Paper Design Theory (Class: XI/XII)

Max. Marks : 70

Duration : 3 Hours

S.No.	Typology	Total Marks	Approximate Percentage
1.	Remembering : Exhibit memory of previously learned material by recalling facts, terms, basic concepts, and answers.	27	38%
	Understanding : Demonstrate understanding of facts and ideas by organizing, comparing, translating, interpreting, giving descriptions, and stating main ideas.		
2.	Applying : Solve problems to new situations by applying acquired knowledge, facts, techniques and rules in a different way.	22	32%
3.	Analysing : Examine and break information into parts by identify motives or causes. Make inferences and find evidence to support generalizations Evaluating : Present and defend opinions by making judgments about information, validity of ideas, or quality of work based on a set of criteria. Creating : Compile information together in a different way by combining elements in a new pattern of proposing alternative solutions.	21	30%
	Total Marks	70	100
	Practical	30	
	Gross Total	100	

Note:

The above template is only a sample. Suitable internal variation may be made for generating similar templates keeping the overall weightage to different form of questions and typology of questions same.

For more details kindly refer to Sample Questions paper of class XII for the year 2023-24 to be published by CBSE at its website.



Practical : 30 Marks

1. **Internal Choice :** *There is no overall choice in the paper. However, there is an internal choice in one in one question of 2 marks weightage, one question of 3 marks weightage and one question of 5 marks weightage (Content based question).*
2. *The above template is only a sample. Suitable internal variations may be made for generating similar templates keeping the overall weightage to different form of questions and typology of questions same.*



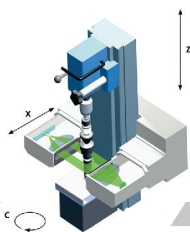

Unit - 1

Dimensions And Measurement

1.1 Physical Quantity

A quantity which can be measured and expressed in form of laws is called a physical quantity. Physical quantity (Q) = Magnitude \times Unit = $n \times u$

Where, n represents the numerical value and u represents the unit. as the unit(u) changes, the magnitude (n) will also change but product ' nu ' will remain same.

i.e. $n u = \text{constant}$, or $n_1 u_1 = n_2 u_2 = \text{constant}$;

1.2 Fundamental and Derived Units

Any unit of mass, length and time in mechanics is called a *fundamental, absolute or base unit*. Other units which can be expressed in terms of fundamental units, are called derived units

System of units : A complete set of units, both fundamental and derived for all kinds of physical quantities is called system of units.

- (1) CGS system, (2) MKS system, (3) FPS system.
- (4) **S.I. system** : It is known as International system of units. There are seven fundamental quantities in this system. These quantities and their units are given in the following table.

Quantity	Name of Units	Symbol
Length	Metre	m
Mass	Kilogram	kg
Time	Second	s
Electric Current	Ampere	A
Temperature	Kelvin	K
Amount of Substance	Mole	Mol
Luminous Intensity	Candela	Cd

Besides the above seven fundamental units two supplementary units are also defined - Radian (*rad*) for plane angle and Steradian (*sr*) for solid angle.

1.3 Dimensions of a Physical Quantity

When a derived quantity is expressed in terms of fundamental quantities, it is written as a product of different powers of the fundamental quantities. The powers to which fundamental quantities must be raised in order to express the given physical quantity are called its dimensions.

1.4 Important Dimensions of Complete Physics

Mechanics

S.N.	Quantity	Unit	Dimension
(1)	Velocity or speed (v)	m/s	$[M^0L^1T^{-1}]$
(2)	Acceleration (a)	m/s^2	$[M^0LT^{-2}]$
(3)	Momentum (P)	kg.m/s	$[M^1L^1T^{-1}]$
(4)	Impulse (I)	Newton/sec or kg. m/s	$[M^1L^1T^{-1}]$
(5)	Force (F)	Newton	$[M^1L^1T^{-2}]$
(6)	Pressure (P)	Pascal	$[M^1L^{-1}T^{-2}]$
(7)	Kinetic energy (E_k)	Joule	$[M^1L^2T^{-2}]$
(8)	Power (P)	Watt or Joule/s	$[M^1L^2T^{-3}]$
(9)	Density (d)	kg/m^3	$[M^1L^{-3}T^0]$
(10)	Angular displacement (θ)	Radian (rad.)	$[M^0L^0T^0]$
(11)	Angular velocity (ω)	Radian/sec	$[M^0L^0T^{-1}]$
(12)	Angular Acceleration (α)	Radian/sec ²	$[M^0L^0T^{-2}]$
(13)	Moment of inertia (I)	$kg.m^2$	$[ML^2T^0]$
(14)	Torque (τ)	Newton-meter	$[ML^2T^{-2}]$
(15)	Angular momentum (L)	Joule sec	$[ML^2T^{-1}]$
(16)	Force constant or spring constant (k)	Newton/m	$[M^1L^0T^{-2}]$
(17)	Gravitational constant (G)	$N-m^2/kg^2$	$[M^{-1}L^3T^{-2}]$

(18)	Intensity of gravitational field (E_g)	N/kg	$[M^0L^1T^{-2}]$
(19)	Gravitational potential (V_g)	Joule/kg	$[M^0L^2T^{-2}]$
(20)	Surface tension (T)	N/m or Joule/m ²	$[M^1L^0T^{-2}]$
(21)	Velocity gradient (V_g)	Second ⁻¹	$[M^0L^0T^{-1}]$
(22)	Coefficient of viscosity (η)	kg/m s	$[M^1L^{-1}T^{-1}]$
(23)	Stress	N/m ²	$[M^1L^{-1}T^{-2}]$
(24)	Strain	No unit	$[M^0L^0T^0]$
(25)	Modulus of elasticity (E)	N/m ²	$[M^0L^{-1}T^{-2}]$
(26)	Poisson Ratio (σ)	No unit	$[M^0L^0T^0]$
(27)	Time period (T)	Second	$[M^0L^0T^1]$
(28)	Frequency (n)	Hz	$[M^0L^0T^{-1}]$

Heat

S.N.	Quantity	Unit	Dimension
(1)	Temperature (T)	Kelvin	$M^0L^0T^0K^1]$
(2)	Heat (Q)	Joule	$[ML^2T^{-2}]$
(3)	Specific Heat (c)	Joule/Kg–K	$[M^0L^2T^{-2}K^{-1}]$
(4)	Thermal capacity	Joule/K	$[M^1L^2T^{-2}K^{-1}]$
(5)	Latent heat (L)	Joule/kg	$[M^0L^2T^{-2}]$
(6)	Gas constant (R)	Joule/mol-K	$[M^1L^2T^{-2}mol^{-1}K^{-1}]$
(7)	Boltzmann constant (k)	Joule/K	$[M^1L^2T^{-2}K^{-1}]$
(8)	Coefficient of thermal conductivity (K)	Joule/M-s-K	$[M^1L^1T^{-3}K^{-1}]$
(9)	Stefan's constant (σ)	Watt/m ² –K ⁴	$[M^1L^0T^{-3}K^{-4}]$
(10)	Wien's constant (b)	Meter K	$[M^0L^1T^0K^1]$
(11)	Planck's constant (h)	Joule s	$[M^1L^2T^{-1}]$
(12)	Coefficient of Linear Expansion	Kelvin ⁻¹	$[M^0L^0T^0K^{-1}]$

(13)	Mechanical eq. of Heat (J)	Joule/Calorie	$[M^0L^0T^0]$
(14)	Vander wall's constant (a)	Newton m ⁴	$[M^1L^5T^{-2}]$
(15)	Vander wall's constant (b)	m ³	$[M^0L^3T^0]$

1.5 Quantities Having Same Dimensions

S.N.	Dimension	Quantity
(1)	$[M^0L^0T^{-1}]$	Frequency, angular frequency, angular velocity, velocity gradient and decay constant
(2)	$[M^1L^2T^{-2}]$	Work, internal energy, potential energy, kinetic energy, torque, moment of force
(3)	$[M^1L^{-1}T^{-2}]$	Pressure, stress, Young's modulus, bulk modulus, modulus of rigidity, energy density
(4)	$[M^1L^1T^{-1}]$	Momentum, impulse
(5)	$[M^0L^1T^{-2}]$	Acceleration due to gravity, gravitational field intensity
(6)	$[M^1L^1T^{-2}]$	Thrust, force, weight, energy gradient
(7)	$[M^1L^2T^{-1}]$	Angular momentum and Planck's constant
(8)	$[M^1L^0T^{-2}]$	Surface tension, Surface energy (energy per unit area)
(9)	$[M^0L^0T^0]$	Strain, refractive index, relative density, angle, solid angle, distance gradient, relative permittivity (dielectric constant), relative permeability etc.
(10)	$[M^0L^2T^{-2}]$	Latent heat and gravitational potential
(11)	$[M^0L^0T^{-2}K^{-1}]$	Thermal capacity, gas constant, Boltzmann constant and entropy
(12)	$[M^0L^0T^1]$	$\sqrt{l/g}, \sqrt{m/k}, \sqrt{R/g}$, g = acceleration due to gravity, m = mass, k = spring constant
(13)	$[M^0L^0T^1]$	L/R \sqrt{LC} , RC where L = inductance, R = resistance, C = capacitance
(14)	$[ML^2T^{-2}]$	$I^2Rt, \frac{V^2}{R}t, VIt, qV, LI^2, \frac{q^2}{C}, CV^2$ where I = current, t = time q = charge, L = inductance, C = capacitance, R = resistance

1.6 Application of Dimensional Analysis.

- (1) To find the unit of a physical quantity in a given system of units.
- (2) To find dimensions of physical constant or coefficients.
- (3) To convert a physical quantity from one system to the other.
- (4) To check the dimensional correctness of a given physical relation: This is based on the '*principle of homogeneity*'. According to this principle the dimensions of each term on both sides of an equation must be the same.
- (5) To derive new relations.

1.7 Limitations of Dimensional Analysis.

- (1) If dimensions are given, physical quantity may not be unique.
- (2) Numerical constant having no dimensions cannot be deduced by the methods of dimensions.
- (3) The method of dimensions can not be used to derive relations other than product of power functions. For example,
$$s = u t + (1/2) a t^2 \quad \text{or} \quad y = a \sin \omega t$$
- (4) The method of dimensions cannot be applied to derive formula consist of more than 3 physical quantities.

1.8 Significant Figures

Significant figures in the measured value of a physical quantity tell the number of digits in which we have confidence. Larger the number of significant figures obtained in a measurement, greater is the accuracy of the measurement. The reverse is also true.

The following rules are observed in counting the number of significant figures in a given measured quantity.

- (1) All non-zero digits are significant.
- (2) A zero becomes significant figure if it appears between two non-zero digits.
- (3) Leading zeros or the zeros placed to the left of the number are never significant.

Example : 0.543 has three significant figures.

 0.006 has one significant figures.

- (4) Trailing zeros or the zeros placed to the right of the number are significant.

Example : 4.330 has four significant figures.

 343.000 has six significant figures.

- (5) In exponential notation, the numerical portion gives the number of significant figures.

Example : 1.32×10^{-2} has three significant figures.

1.9 Rounding Off

- (1) If the digit to be dropped is less than 5, then the preceding digit is left unchanged.

Example : $x = 7.82$ is rounded off to 7.8, again $x = 3.94$ rounded off to 3.9.

- (2) If the digit to be dropped is more than 5, then the preceding digit is raised by one.

Example : $x = 6.87$ is rounded off to 6.9, again $x = 12.78$ is rounded off to 12.8.

- (3) If the digit to be dropped is 5 followed by digits other than zero, then the preceding digit is raised by one.

Example : $x = 16.351$ is rounded off to 16.4, again $x = 6.758$ is rounded off to 6.8.

- (4) If digit to be dropped is 5 or 5 followed by zeros, then preceding digit is left unchanged, if it is even.

Example : $x = 3.250$ becomes 3.2 on rounding off, again $x = 12.650$ becomes 12.6 on rounding off.

- (5) If digit to be dropped is 5 or 5 followed by zeros, then the preceding digit is raised by one, if it is odd.

Example : $x = 3.750$ is rounded off to 3.8, again $x = 16.150$ is rounded off to 16.2.

1.10 Significant Figures in Calculation

The following two rules should be followed to obtain the proper number of significant figures in any calculation.

- (1) The result of an addition or subtraction in the number having different precisions should be reported to the same number of decimal places as are present in the number having the least number of decimal places.
- (2) The answer to a multiplication or division is rounded off to the same number of significant figures as is possessed by the least precise term used in the calculation.

1.11 Order of Magnitude

Order of magnitude of quantity is the power of 10 required to represent the quantity. For determining this power, the value of the quantity has to be rounded off. While rounding off, we ignore the last digit which is less than 5. If the last digit is 5 or more than five, the preceding digit is increased by one.

For example,

- (1) Speed of light in vacuum = $3 \times 10^8 \text{ ms}^{-1} \approx 10^8 \text{ m/s}$ (ignoring $3 < 5$)
- (2) Mass of electron = $9.1 \times 10^{-31} \text{ kg} \approx 10^{-30} \text{ kg}$ (as $9.1 > 5$).

1.12 Errors of Measurement.

The measured value of a quantity is always somewhat different from its actual value, or true value. This difference in the true value of a quantity is called error of measurement.

- (1) **Absolute error**—Absolute error in the measurement of a physical quantity is the magnitude of the difference between the true value and the measured value of the quantity.

Let a physical quantity be measured n times. Let the measured value be $a_1, a_2, a_3, \dots, a_n$. The arithmetic mean of these value is $a_m = \frac{a_1 + a_2 + \dots + a_n}{n}$

Usually, a_m is taken as the true value of the quantity, if the same is unknown otherwise.

By definition, absolute errors in the measured values of the quantity are

$$\Delta a_1 = a_m - a_1$$

$$\Delta a_2 = a_m - a_1$$

.....

$$\Delta a_n = a_m - a_n$$

The absolute errors may be positive in certain cases and negative in certain other cases.

- (2) **Mean absolute error**—It is the arithmetic mean of the magnitudes of absolute errors in all the measurements of the quantity. It is represented by Δa . Thus

$$\Delta a = \frac{|\Delta a_1| + |\Delta a_2| + \dots + |\Delta a_n|}{n}$$

Hence the final result of measurement may be written as $a = a_m \pm \overline{\Delta a}$

This implies that any measurement of the quantity is likely to lie between

$$(a_m - \overline{\Delta a}) \text{ and } (a_m + \overline{\Delta a}).$$

(3) **Relative error or Fractional error**—Relative error or Fractional error

$$= \frac{\text{mean absolute error}}{\text{mean value}} = \frac{\overline{\Delta a}}{a_m}.$$

(4) **Percentage error** : Percentage error = $\frac{\overline{\Delta a}}{a_m} \times 100\%$.

1.13 Propagation of Errors

(1) **Error in sum of the quantities** : Suppose $x = a + b$

Let Δa = absolute error in measurement of a

Δb = absolute error in measurement of b

Δx = absolute error in calculation of x i.e. sum of a and b .

The maximum absolute error in x is $\Delta x = \pm (\Delta a + \Delta b)$

(2) **Error in difference of the quantities**—Suppose $x = a - b$

The maximum absolute error in x is $\Delta x = \pm (\Delta a + \Delta b)$

(3) **Error in product of quantities**—Suppose $x = a \times b$

The maximum fractional error in x is $\frac{\Delta x}{x} = \pm \left(\frac{\Delta a}{a} + \frac{\Delta b}{b} \right)$

(4) **Error in division of quantities**—Suppose $x = \frac{a}{b}$

The maximum fractional error in x is $\frac{\Delta x}{x} = \pm \left(\frac{\Delta a}{a} + \frac{\Delta b}{b} \right)$

(5) **Error in quantity raised to some power**—Suppose $x = \frac{a^n}{b^m}$

The maximum fractional error in x is $\frac{\Delta x}{x} = \pm \left(n \frac{\Delta a}{a} + m \frac{\Delta b}{b} \right)$

- The quantity which have maximum power must be measured carefully because it's contribution to error is maximum.

UNIT I – UNITS & MEASUREMENT

1. A new unit of length is chosen such that the speed of light in vacuum is unity. What is the distance between the sun and the earth in terms of the new unit if light takes 8 min and 20 s to cover this distance.

2. If $x = a + bt + ct^2$, where x is in metre and t in seconds, what is the unit of c ?
3. What is the difference between mN , Nm and nm ?
4. The radius of atom is of the order of 1\AA & radius of Nucleus is of the order of fermi. How many magnitudes higher is the volume of the atom as compared to the volume of nucleus ?
5. How many kg make 1 unified atomic mass unit ?
6. Name same physical quantities that have same dimension.
7. Name the physical quantities that have dimensional formula $[ML^{-1}T^{-2}]$.
8. Give two examples of dimension less variables.
9. State the number of significant figures in

(i) 0.007 m ²	(ii) 2.64×10^{24} kg
(iii) 0.2370 g cm ⁻³	(iv) 0.2300m
(v) 86400	(vi) 86400 m
10. Given relative error in the measurement of length is .02, what is the percentage error ?
11. A physical quantity P is related to four observables a , b , c and d as follows :

$$P = \frac{a^3 b^2}{d \sqrt{c}}$$

The percentage errors of measurement in a , b , c and d are 1%, 3%, 4% and 2% respectively. What is the percentage error in the quantity P?
12. A boy recalls the relation for relativistic mass (m) in terms of rest mass (m_0) velocity of particle V , but forgets to put the constant c (velocity of light). He writes $m = \frac{m_0}{(1 - v^2)^{1/2}}$ correct the equation by putting the missing 'c'.
13. Name the technique used in locating.
 - (a) an under water obstacle
 - (b) position of an aeroplane in space.
14. Deduce dimensional formulae of—
 - (i) Boltzmann's constant
 - (ii) mechanical equivalent of heat.
15. Give examples of dimensional constants and dimensionless constants.

SHORT ANSWER QUESTIONS (2 MARKS)

16. The vernier scale of a travelling microscope has 50 divisions which coincide with 49 main scale divisions. If each main scale division is 0.5 mm. Calculate the minimum inaccuracy in the measurement of distance.
17. If the unit of force is 100N, unit of length is 10m and unit of time is 100s. What is the unit of Mass in this system of units ?
18. Describe the principle and use of SONAR and RADAR.
19. State the principle of homogeneity. Test the dimensional homogeneity of equations—
- (i) $s = ut + \frac{1}{2} at^2$
- (ii) $S_n = u + \frac{a}{2}(2n-1)$
20. In Vander Wall's gas equation $\left(P + \frac{a}{V^2}\right)(V-b) = RT$. Determine the dimensions of a and b .
21. Using dimensions convert (a) 1 newton into dynes (b) 1 erg into joules.
22. Magnitude of force experienced by an object moving with speed v is given by $F = kv^2$. Find dimensions of k .
23. A book with printing error contains four different formulae for displacement. Choose the correct formula/formulae
- (a) $y = a \sin \frac{2\pi}{T}t$ (b) $y = a \sin vt$
- (c) $y = \frac{a}{T} \sin\left(\frac{t}{a}\right)$
- (d) $y = \frac{a}{T} \left(\sin \frac{2\pi}{T}t + \cos \frac{2\pi}{T}t\right)$
24. Give limitations of dimensional analysis.
25. For determination of 'g' using simple pendulum, measurements of length and time period are required. Error in the measurement of which quantity will have larger effect on the value of 'g' thus obtained. What is done to minimise this error?

SHORT ANSWER QUESTIONS (3 MARKS)

26. Give the name of six Indian Scientists and their discoveries.
27. Name the discoveries made by the following scientists :
- (a) Faraday (b) Chadwick
(c) Hubble (d) Maxwell
(e) Newton (f) Bohr.
28. Name the scientific principle on which the following technology is based.
- (i) Steam engine (ii) Laser
(iii) Aeroplane (iv) Rocket propulsion
(v) Radio and T.V.
(vi) Production of Ultra high magnetic field.
29. Describe a method for measuring the molecular size of Oleic acid.

[3 MARKS]

30. Describe the Parallax Method for the determination of the distance of a nearby star from the earth.
31. Deduce the dimensional formula for the following quantities
- (i) Gravitational constant (ii) Young's modulus
(iii) Coefficient of viscosity.
32. Define the following units :
- (i) Light year (ii) Parsec
(iii) Astronomical unit (AU)

LONG ANSWER QUESTIONS (5 MARKS)

33. Name the four basic forces in nature. Write a brief note of each. Hence compare their strengths and ranges.
34. Distinguish between the terms precision and accuracy of a measurement.
35. Explain
- (i) absolute error (ii) mean absolute error
(iii) relative error (iv) percentage error
(v) random error

NUMERICALS

36. Determine the number of light years in one metre.
37. The sides of a rectangle are (10.5 ± 0.2) cm and (5.2 ± 0.1) cm. Calculate its perimeter with error limits.
38. The mass of a box measured by a grocer's balance is 2.3 kg. Two gold pieces 20.15 g and 20.17 g are added to the box.
- What is the total mass of the box ?
 - The difference in masses of the pieces to correct significant figures.
39. 5.74 g of a substance occupies 1.2 cm^3 . Express its density to correct significant figures.
40. If displacement of a body $s = (200 \pm 5) \text{ m}$ and time taken by it $t = (20 + 0.2) \text{ s}$, then find the percentage error in the calculation of velocity.
41. If the error in measurement of mass of a body be 3% and in the measurement of velocity be 2%. What will be maximum possible error in calculation of kinetic energy.
42. The length of a rod as measured in an experiment was found to be 2.48m, 2.46m, 2.49m, 2.50m and 2.48m. Find the average length, absolute error and percentage error. Express the result with error limit.
43. A physical quantity is measured as $Q = (2.1 \pm 0.5)$ units. Calculate the percentage error in (1) Q^2 (2) $2Q$.
44. When the planet Jupiter is at a distance of 824.7 million km from the earth, its angular diameter is measured to be $35.72''$ of arc. Calculate diameter of Jupiter.
45. A laser light beamed at the moon takes 2.56s and to return after reflection at the moon's surface. What will be the radius of lunar orbit.
46. Convert
- 3 ms^{-2} to km h^{-2}
 - $G = 6.67 \times 10^{-11} \text{ N m}^2 \text{ kg}^{-2}$ to $\text{cm}^3 \text{ g}^{-1} \text{ s}^{-2}$
47. A calorie is a unit of heat or energy and it equals 4.2 J where $1\text{J} = 1 \text{ kg m}^2\text{s}^{-2}$. Suppose we employ a system of units in which unit of mass is $\alpha \text{ kg}$, unit of length is $\beta \text{ m}$, unit of time $\gamma \text{ s}$. What will be magnitude of calorie in terms of this new system.

48. The escape velocity v of a body depends on—
- the acceleration due to gravity 'g' of the planet,
 - the radius R of the planet. Establish dimensionally the relation for the escape velocity.
49. The frequency of vibration of a string depends of on, (i) tension in the string (ii) mass per unit length of string, (iii) vibrating length of the string. Establish dimensionally the relation for frequency.
50. One mole of an ideal gas at STP occupies 22.4 L. What is the ratio of molar volume to atomic volume of a mole of hydrogen? Why is the ratio so large. Take radius of hydrogen molecule to be 1°A .
51. Derive an expression for the centripetal force F acting on a particle of mass m moving with velocity v in a circle of radius r .
52. The error in the measurement of radius of a sphere is 2%. What would be the error in :
- Volume of sphere
 - Surface area of sphere.

ASSERTION - REASON BASED QUESTIONS

In the following questions, a statement of Assertion (A) is followed by a corresponding statement of reason (R) of the following statements, choose the correct one.

- Assertion and reason both are correct statements and reason is correct explanation for assertion.
- Assertion and reason both are correct statements but reason is not correct explanation for assertion.
- Assertion is correct statement but reason is wrong statement.
- Assertion is wrong statement but reason is correct statement.

1. Assertion : The error in the measurement of radius of a sphere is 0.3%. The permissible error in its surface area is 0.6%.

Reason : The permissible error is calculated by the formula $\frac{\Delta A}{A} = 4 \frac{\Delta r}{r}$.

2. Assertion : If the units of force and length are doubled, the unit of energy will become four times.

Reason : The unit of energy is independent of the units of force and length.

3. Assertion : Parallax method cannot be used for measuring distances of stars more than 100 light years away.
Reason : Because parallax angle reduces so much that it cannot be measured accurately.
4. Assertion : Distance travelled by a particle in n^{th} second has the dimension of length.
Reason : It is the distance travelled in a particular second.
5. Assertion : Force and pressure cannot be added.
Reason : The dimensions of force and pressure are different.
6. Assertion : In the relation $f = \frac{1}{2l} \sqrt{\frac{T}{m}}$, where symbols have standard meaning, m represents linear mass density.
Reason : The frequency has the dimensions of inverse of time.
7. Assertion : The big G and small g have the same dimensions.
Reason : G is a gravitational constant and ' g ' is the acceleration due to gravity.
8. Assertion : In quantum mechanics, angular momentum is measured in terms of Planck's constant.
Reason : Angular momentum and Planck's constant have the same dimension.
9. Assertion : Number of significant figure in 0.005 is one and in 0.500 is three.
Reason : This is because zeros are not significant.
10. Assertion : The unit of LC is (second)², where L is induction and C is the capacitance.
Reason : The relation between LC and time period (T) is $T = \frac{1}{2\pi\sqrt{LC}}$.

CASE STUDY BASED QUESTIONS

- Q1.** The nature of physical quantity is described by its dimension. All the physical quantities can be expressed in terms of some combination of seven fundamental units. The dimensions of a physical quantity are thus the powers to which the base quantities are raised to represent that quantity.

If a given physical quantity depends on a^{th} power of mass, b^{th} power of length, c^{th} power of time etc., then its dimensions are expressed as $[M^a L^b T^c]$.

- (i) The dimension of Planck's constant equal to that of
- (a) energy (b) momentum
(c) angular momentum (d) power
- (ii) If force (F), velocity (v) and time (T) are taken as fundamental units, then dimension of mass are
- (a) $[FVT^{-2}]$ (b) $[FV^{-1}T^{-1}]$
(c) $[FV^{-1}T]$ (d) $[FVT^{-1}]$
- (iii) Which of the following sets have different dimensions
- (a) Pressure and Young's modulus
(b) Emf and potential difference
(c) Heat and work done
(d) Dipole moment and electric flux
- (iv) The dimensions of $a \times b$ in the relations :-
 $P = \frac{b-x^2}{at}$, where P is power, x is distance and t is time.
- (a) $[M^{-1} L^2 T^2]$ (b) $[M^{-1} L^0 T^2]$
(c) $[M^0 L^2 T^0]$ (d) $[ML^2 T^{-1}]$
- (v) Find the value of 100 J on a system which has 20 cm, 250 g and half minute as fundamental units of length, mass and time.
- (a) 9×10^{-6} new units (b) 2.16×10^6 new units
(c) 9×10^6 new units (d) 100 new units

Q2. The Vanderwaals equation is

$$\left(P + \frac{a}{v^2}\right)(V - b) = RT$$

Where P is pressure, V is volume, T is absolute temperature of given sample of a gas, R is called molar gas constant, a and b are Vanderwaal's constant.

Now answer the following

- (i) The dimensional formula for b is same as for
(a) V^2 (b) PV^2
(c) RT (d) P
- (ii) The dimensional formula for a is same as for
(a) V^2 (b) P
(c) PV^2 (d) RT
- (iii) The dimensional formula of $\frac{ab}{RT}$ is
(a) $ML^5 T^{-2}$ (b) $M^0 L^3 T^0$
(c) $ML^{-1} T^{-2}$ (d) $M^0 L^6 T^0$
- (iv) The dimensional formula for RT is same as for
(a) Energy (b) Force
(c) Latent heat (d) Specific heat
- (v) The dimensional formula for RT is not same as that for
(a) $\frac{ab}{V^2}$ (b) PV (c) $\frac{b}{V^2}$ (d) PV

Q3. For the propagation of errors, we have the following conclusions

If a and b are two physical quantities and another physical quantity X is expressed as

- (a) when $X = a \pm b$

$$\text{then } \Delta X = \pm (\Delta a + \Delta b)$$

where ΔX is error in X

- (b) When $X = ab$, then maximum error is ΔX

$$\text{then } \frac{\Delta X}{X} = \frac{\Delta a}{a} + \frac{\Delta b}{b}$$

- (c) When $X = \frac{ab}{a+b}$

$$\text{then } \frac{\Delta X}{X} = \frac{\Delta a}{a} + \frac{\Delta b}{b} + \left(\frac{\Delta a + \Delta b}{a+b} \right)$$

Now answer the following

- (i) A car runs 1200 m in 22.5 sec. The average speed of car in appropriate significant figures.
- (a) 53.3 m/s (b) 53.33 m/s
(c) 53.333 m/s (d) None of these
- (ii) The radius of a uniform wire $r = 0.024$ cm. Take $\pi = 3.142$, then area of cross-section upto appropriate significant figures.
- (a) 0.001808 cm² (b) 0.0018086 cm²
(c) 0.0018 cm² (d) 18.08 cm²
- (iii) The volume of sphere is 2.42 cm³. The volume of 15 spheres taking into account the significant figures.
- (a) 29.0 cm³ (b) 29.04 cm³
(c) 29.1 cm³ (d) 29 cm³
- (iv) The length of a rectangular block is 2.5 m, breadth is 1.75 m. The area of surface of block taking into account of the significant figures.
- (a) 4.38 m² (b) 4.3 m²
(c) 4.4 m² (d) 4.375 m²
- (v) The number of significant figures in 0.06900 is -
- (a) 5 (b) 4
(c) 2 (d) 3

SOLUTIONS

1. Speed of light in vacuum, $c = 1$ new unit of length s^{-1}

$$t = 8 \text{ min. } 20 \text{ sec,} = 500 \text{ s}$$

$$x = ct = 1 \text{ new unit of length } s^{-1} \times 500s$$

$$x = 500 \text{ new unit of length}$$

2. The unit of left hand side is metre so the units of ct^2 should also be metre. Since t^2 has unit of s^2 , so the unit of c is m/s^2 .
3. mN means milli newton, $1 \text{ mN} = 10^{-3} \text{ N}$, Nm means Newton meter, nm means nano meter.

$$4. \frac{V_{\text{atom}}}{V_{\text{nucleus}}} = \frac{4\pi(10^{-10} \text{ m})^3}{4\pi(10^{-15} \text{ m})^3} = 10^{15}$$

5. $1u = 1.66 \times 10^{-27} \text{ kg}$
6. Work, energy and torque.
7. Stress, pressure, modulus of elasticity.
8. Strain, refractive index.
9. (i) 1, (ii) 3, (iii) 4, (iv) 4, (v) 3, (vi) 5 since it comes from a measurement the last two zeros become significant.
10. 2%.

11. Relative error in P is given by

$$\frac{\Delta P}{P} = 3 \frac{\Delta a}{a} + 2 \frac{\Delta b}{b} + \frac{1}{2} \frac{\Delta c}{c} + \frac{\Delta d}{d}$$

So, percentage error

$$\begin{aligned} \frac{\Delta P}{P} \times 100 &= 3 \left(\frac{\Delta a}{a} \times 100 \right) + 2 \left(\frac{\Delta b}{b} \times 100 \right) + \frac{1}{2} \left(\frac{\Delta c}{c} \times 100 \right) + \frac{\Delta d}{d} \times 100 \\ &= (3 \times 1\%) + (2 \times 3\%) + \left(\frac{1}{2} \times 4\% \right) + (1 \times 2\%) \\ &= 13\% \end{aligned}$$

Rounded off value of P = 3.8.

12. Since quantities of similar nature can only be added or subtracted, v^2 cannot be subtracted from 1 but v^2/c^2 can be subtracted from 1.

$$\therefore m = \frac{m_0}{\sqrt{1 - v^2/c^2}}$$

13. (a) SONAR → Sound Navigation and Ranging.
 (b) RADAR → Radio Detection and Ranging.

14. (i) Boltzmann Constant :

$$k = \frac{\text{Heat}}{\text{Temperature}} \Rightarrow [k] = \frac{\text{ML}^2\text{T}^{-2}}{\text{K}} = [\text{M}^1\text{L}^2\text{T}^{-2}\text{K}^{-1}]$$

$$(ii) [J] = \left[\frac{\text{Work}}{\text{Heat}} \right] = \frac{\text{M}^1\text{L}^2\text{T}^{-2}}{\text{M}^1\text{L}^2\text{T}^{-2}} = [\text{M}^0\text{L}^0\text{T}^0]$$

15. Dimensional Constants : Gravitational constant, plank's constant.
 Dimensionless Constants : π , e.

16. Minimum inaccuracy = Vernier constant
 $= 1 \text{ MSD} - 1 \text{ VS.D}$
 $= 1 \text{ MSD} - \frac{49}{50} \text{ MSD}$
 $= \frac{1}{50} (0.5 \text{ mm}) = 0.01 \text{ mm}$

17. $[F] = [MLT^{-2}]$

$$[M] = \frac{[F]}{[L][T^{-2}]} = \frac{[100N]}{[10m][100s]^{-2}} = 10^5 \text{kg.}$$

19. (i) Dimension of L.H.S. = $[s] = [M^0L^1T^0]$
 Dimension of R.H.S. = $[ut] + [at^2]$
 $= [LT^{-1} \cdot T] + [M^0L^1T^{-2} \cdot T^2] = [M^0L^1T^0]$

as Dimensions of L.H.S. = Dimensions of R.H.S.

\therefore The equation to dimensionally homogeneous.

(ii) $S_n =$ Distance travelled in n^{th} sec that is $(S_n - S_{n-1})$

$$\therefore S_n = u \times 1 + \frac{a}{2}(2n-1)$$

$$[LT^{-1}] = [LT^{-1}] + [LT^{-2}][T]$$

$$[LT^{-1}] = [LT^{-1}]$$

L.H.S. = R.H.S.

Hence this is dimensionally correct.

20. Since dimensionally similar quantities can only be added

$$\therefore [P] = \left[\frac{a}{V^2} \right] \Rightarrow [a] = [PV^2] = [M^1L^5T^{-2}]$$

$$[b] = [V] = [L^3].$$

22. $[K] = \frac{[F]}{[v^2]} = \frac{M^1L^1T^{-2}}{[LT^{-1}]^2} = \frac{M^1L^1T^{-2}}{M^0L^2T^{-2}} = [M^1L^{-1}]$

23. The argument of sine and cosine function must be dimensionless so (a) is the probable correct formula. Since

(a) $y = a \sin \left(\frac{2\pi}{T} t \right), \therefore \left[\frac{2\pi t}{T} \right] = [T^0]$ is dimensionless.

(b) $y = a \sin vt, \therefore [vt] = [L]$ is dimensional so this equation is incorrect.

(c) $y = \frac{a}{t} \sin\left(\frac{t}{a}\right)$, $\because \left[\frac{t}{a}\right]$ is dimensional so this is incorrect.

(d) $y = \frac{a}{t} \left(\sin \frac{2\pi}{T} t + \cos \frac{2\pi t}{T} \right)$: Though $\frac{2\pi t}{T}$ dimensionless $\frac{a}{T}$ does not have dimensions of displacement so this is also incorrect.

(NUMERICAL)

36. $1 \text{ Iy} = 9.46 \times 10^{15} \text{ m}$

$$1 \text{ m} = \frac{1}{9.46 \times 10^{15}} = 1.057 \times 10^{-16} \text{ Iy}$$

37. $P = 2(l + b) \pm 2(\Delta l + \Delta b)$
 $= 2(10.5 + 5.2) \pm 2(0.2 + 0.1)$
 $= (31.4 \pm 0.6) \text{ cm.}$

38. (i) Mass of box = 2.3 kg
 Mass of gold pieces = 20.15 + 20.17 = 40.32 g = 0.04032 kg.
 Total mass = 2.3 + 0.04032 = 2.34032 kg
 In correct significant figure mass = 2.3 kg (as least decimal)

(ii) Difference in mass of gold pieces = 0.02 g
 In correct significant figure (2 significant fig. minimum decimal) will be 0.02 g.

39. Density = $\frac{\text{Mass}}{\text{Volume}} = \frac{5.74}{1.2} = 4.783 \text{ g/cm}^3$

Here least significant figure is 2, so density = 4.8 g/cm³.

40. Percentage error in measurement of displacement = $\frac{5}{200} \times 100$

Percentage error in measurement of time = $\frac{0.2}{20} \times 100$

\therefore Maximum permissible error = 2.5 + 1 = 3.5%

41. K.E. = $\frac{1}{2}mv^2$

$$\therefore \frac{\Delta k}{k} = \frac{\Delta m}{m} + \frac{2\Delta v}{v} \Rightarrow \frac{\Delta k}{k} \times 100 = \frac{\Delta m}{m} \times 100 + 2 \left(\frac{\Delta v}{v} \right) \times 100$$

\therefore Percentage error in K.E. = 3% + 2 × 2% = 7%

42. Average length

$$= \frac{2.48 + 2.46 + 2.49 + 2.50 + 2.48}{5} = \frac{12.41}{5} = 2.48\text{m}$$

Mean absolute error

$$= \frac{0.00 + 0.02 + 0.01 + 0.02 + 0.00}{5} = \frac{0.05}{5} = 0.013\text{m}$$

$$\begin{aligned} \text{Percentage error} &= \frac{0.01}{2.48} \times 100\% = 0.04 \times 100\% \\ &= 0.40\% \end{aligned}$$

$$\text{Correct length} = (2.48 \pm 0.01)\text{m}$$

$$\text{Correct length} = (2.48\text{m} \pm 0.40\%)$$

43. $P = Q^2$

$$\frac{\Delta P}{P} = \frac{2\Delta Q}{Q} = 2 \left(\frac{0.5}{2.1} \right) = \frac{1.0}{2.1} = 0.476$$

$$\frac{\Delta P}{P} \times 100\% = 47.6\% = 48\%$$

$$R = 2Q$$

$$\frac{\Delta R}{R} = \frac{\Delta Q}{Q} \Rightarrow \frac{0.5}{2.1} = 0.238$$

$$\frac{\Delta R}{R} \times 100\% = 24\%$$

44. $\theta = 35.72''$

$$1'' = 4.85 \times 10^{-6} \text{ radian} \Rightarrow 35.72'' = 35.72 \times 4.85 \times 10^{-6} \text{ rad.}$$

$$\begin{aligned} d = DQ &= 824.7 \times 35.72 \times 4.85 \times 10^{-6} \\ &= 1.4287 \times 10^5 \text{ km} \end{aligned}$$

45. $t = 2.56 \text{ s}$

$$\therefore t = \text{time taken by laser beam to go to the moon} = \frac{t}{2}$$

distance between earth and moon

$$= d = c \times \frac{t}{2} = 3 \times 10^8 \times \frac{2.56}{2} = 3.84 \times 10^8 \text{ m.}$$

$$\begin{aligned}
 46. \text{ (i)} \quad 3\text{m s}^{-2} &= \left(\frac{3}{1000} \text{km} \right) \left(\frac{1}{60 \times 60} \text{hr} \right)^{-2} \\
 &= \frac{3 \times (60 \times 60)^2}{1000} = 3.8880 \times 10^4 \text{ km h}^{-2} = 3.9 \times 10^4 \text{ km h}^{-2}
 \end{aligned}$$

$$\begin{aligned}
 \text{(ii)} \quad G &= 6.67 \times 10^{-11} \text{ N m}^2 \text{ kg}^{-2} \\
 &= 6.67 \times 10^{-11} (\text{kg m s}^{-2}) (\text{m}^2 \text{ kg}^{-2}) \\
 &= 6.67 \times 10^{-11} \text{ kg}^{-1} \text{ m}^3 \text{ s}^{-2} \\
 &= 6.67 \times 10^{-11} (1000 \text{ g})^{-1} (100 \text{ cm})^3 (\text{s}^{-2}) \\
 &= 6.67 \times 10^{-11} \times \frac{1}{1000} \times 100 \times 100 \times 100 \text{ g}^{-1} \text{ cm}^3 \text{ s}^{-2} \\
 &= 6.67 \times 10^{-8} \text{ g}^{-1} \text{ cm}^3 \text{ s}^{-2}.
 \end{aligned}$$

$$\begin{aligned}
 47. \quad n_2 &= n_1 \left[\frac{M_1}{M_2} \right]^a \left(\frac{L_1}{L_2} \right)^b \left(\frac{T_1}{T_2} \right)^c \\
 &= 4.2 \left(\frac{\text{kg}}{\alpha \text{kg}} \right)^1 \left(\frac{\text{m}}{\beta \text{m}} \right)^2 \left(\frac{\text{s}}{\gamma \text{s}} \right)^{-2} \\
 n_2 &= 4.2 \alpha^{-1} \beta^{-2} \gamma^2
 \end{aligned}$$

48. $v \propto g^a R^b \Rightarrow v = k g^a R^b$, $K \rightarrow$ dimensionless proportionality constant

$$[v] = [g]^a [R]^b$$

$$[M^0 L^1 T^{-1}] = [M^0 L^1 T^{-2}]^a [M^0 L^1 T^0]^b$$

equating powers

$$1 = a + b$$

$$-1 = -2a \Rightarrow a = \frac{1}{2}$$

$$b = 1 - a = 1 - \frac{1}{2} = \frac{1}{2}$$

$$\therefore v = k \sqrt{gR}$$

$$49. n \propto I^a T^b m^c, [I] = M^0 L^1 T^0$$

$$[T] = M^1 L^1 T^{-2} \text{ (force)}$$

$$[M] = M^1 L^{-1} T^0$$

$$[M^0 L^0 T^{-1}] = [M^0 L^1 T^0]^a [M^1 L^1 T^{-2}]^b [M^1 L^{-1} T^0]^c$$

$$b + c = 0$$

$$a + b - c = 0$$

$$-2b = -1 \Rightarrow b = \frac{1}{2}$$

$$c = -\frac{1}{2}a = 1$$

$$n \propto \frac{1}{\ell} \sqrt{\frac{T}{m}}$$

$$50. 1 \text{ \AA}^0 = 10^{-10} \text{ m}$$

Atomic volume of 1 mole of hydrogen

$$= \text{Avagadros number} \times \text{volume of hydrogen molecule}$$

$$= 6.023 \times 10^{23} \times \frac{4}{3} \times \pi \times (10^{-10} \text{ m})^3$$

$$= 25.2 \times 10^{-7} \text{ m}^3$$

$$\text{Molar volume} = 22.4 \text{ L} = 22.4 \times 10^{-3} \text{ m}^3$$

$$\frac{\text{Molar volume}}{\text{Atomic volume}} = \frac{22.4 \times 10^{-3}}{25.2 \times 10^{-7}} = 0.89 \times 10^4 \approx 10^4$$

This ratio is large because actual size of gas molecule is negligible in comparison to the inter molecular separation.

$$51. F \propto m^a$$

$$\propto v^b$$

$$r^c$$

$$F = k m^a v^b r^c$$

$$[MLT^{-2}] = [M]^a [LT^{-1}]^b [L]^c$$

$$[M] [L] [T^{-2}] = [M]^a [L]^{b+c} [T]^{-b}$$

Comparing powers of m, L and T

$$a = 1$$

$$b+c = 1$$

$$-2 = -b$$

$$b = -1$$

$$b = 2$$

$$F = k \frac{mv^2}{r}$$

52. (a) $v = \frac{4}{3} \pi R^3$

$$\frac{\Delta V}{V} = 3 \frac{\Delta R}{R} \Rightarrow \frac{\Delta V}{V} \% = 3 \times 2\% = 6\%$$

(b) $A = 4\pi R^2$

$$\frac{\Delta A}{A} = 2 \frac{\Delta R}{R} \Rightarrow \frac{\Delta A}{A} \% = 2 \times 2\% = 4\%$$

ASSERTION - REASON BASED ANSWERS

1. (c) Assertion : As $A = 4\pi r^2$, $\frac{\Delta A}{A} = 2 \frac{\Delta r}{r} = 2 \times 2.03 = 0.6\%$ (True)

Reason : $\frac{\Delta A}{A} = 4 \frac{\Delta r}{r}$ (False)

2. (c) Assertion : Energy = force \times displacement

When the units of force and length are doubled, the unit of energy becomes 4 times. (True)

Reason : Unit of energy is independent of the units of force and length. (False)

3. (a) Assertion : As distance of star increases, parallax angle decreases, and great degree of accuracy is required. (True)

Reason : Due to practical limitations. (True)

4. (d) Assertion : As $S_{\text{nth}} = u + \frac{a}{2} (2n-1)$, S_{nth} has the dimension of velocity $[LT^{-1}]$. (False)

Reason : It is the distance travelled in a particular second. (True)

5. (a) Assertion and reason both are correct and 'R' is the correct explanation of 'A'.

6. (b) Assertion : From $f = \frac{1}{2l} \sqrt{\frac{T}{m}}$, $f^2 = \frac{1}{2l} \sqrt{\frac{T}{m}}$

$$\text{or } m = \frac{T}{4l^2 f^2} = \frac{[\text{MLT}^{-2}]}{[\text{L}^2\text{T}^{-2}]} = \frac{\text{M}}{\text{L}} = \frac{\text{mass}}{\text{length}}$$

Linear mass density. (True)

Reason : It is not a correct explanation of Assertion.

7. (d) Assertion : lim of G is $[\text{M}^{-1}\text{L}^3\text{T}^{-2}]$

lim of g is $[\text{LT}^{-2}]$ (False).

Reason : True.

8. (a) Assertion : True.

Reason : True.

9. (c) Assertion : Since zeros placed to the left of the number are never significant. (True)

Reason : False

10. (c) Assertion : As unit of L/R and CR is a second, unit of LC is (second)². (True)

$$\text{Reason : } \mathbf{V} = \frac{1}{T} = \frac{1}{2\pi\sqrt{LC}} \text{ (True)}$$

$$\text{or } T = 2\pi\sqrt{LC}$$

CASE STUDY BASED ANSWERS

1. (i) (c) (ii) (c) (iii) (d) (iv) (a) (v) (c)

2. (i) (a) (ii) (c) (iii) (d) (iv) (a) (v) (c)

3. (i) (b) (ii) (a) (iii) (c) (iv) (c) (v) (d)

4. (i) (a) (ii) (c) (iii) (d) (iv) (a) (v) (b)

(M.C.Q.) PHYSICAL WORLD & MEASUREMENT

- Which of the following is not the unit of distance?
(a) Light year (b) Astronomical Unit
(c) Parsec (d) Millisecond
- The dimensional formula for ω in the relation $y = A \sin \omega t$ is
(a) $[M^\circ L^\circ T]$ (b) $[M^\circ L^\circ T^{-1}]$
(c) $[ML^\circ T^\circ]$ (d) $[M^\circ L^{-1} T^{-1}]$
- Dimensional formula for curie is
(a) $[M^\circ L T^{-1}]$ (b) $[M^\circ L^{-1} T^\circ]$
(c) $[M^\circ L^\circ T^{-1}]$ (d) $[M^{-1} L^\circ T^\circ]$
- Which of the following pairs of physical quantities does not have same dimensional formula.
(a) Work and torque
(b) Angular momentum and Planck's constant
(c) Tension and surface tension
(d) Impulse and linear momentum
- If momentum (p), Area (A) and time (T) are taken as fundamental quantities, then energy has the dimensional formula :
(a) $[p A^{1/2} T^{-1}]$ (b) $[p A^{-1/2} T^1]$
(c) $[p^2 A T]$ (d) $[p A^{-1} T]$
- Out of 4.0 and 4.00, which is more accurate?
(a) 4.0 (b) 4.00
(c) Both are equally accurate (d) Nothing can be said
- The speed (v) of sound in a gas is given by $v = k P^x \rho^y$
Where K is dimensionless constant, P is pressure, and ρ is the density, then
(a) $x = 1/2, y = 1/2$ (b) $x = -1/2, y = -1/2$
(c) $x = 1/2, y = -1/2$ (d) $x = -1/2, y = 1/2$
- If percentage errors in the measurement of mass and volume of an object are 2% and 3% respectively, then the percentage error in the measurement of the density of the object is :
(a) 1% (b) 0.66%
(c) 5% (d) 6%

9. Given that

$$\int \frac{dx}{\sqrt{2ax-x^2}} = a^n \sin^{-1} \frac{x-a}{a}$$

Where a is a constant. Using dimensional analysis the value of n is

- (a) 1 (b) -1
(c) 0 (d) None of the above
10. In the standard equation $S_{nth} = u + \frac{a}{2}(2n-1)$ what dimensions do you view for S_{nth}
(a) $[M^0 L^1 T^0]$ (b) $[M^0 L^{-1} T]$
(c) $[M^0 L T^{-1}]$ (d) $[M^0 L^0 T^1]$
11. Given force = $\frac{\alpha}{\text{density} + \beta^3}$ what are dimensions of α, β ?
(a) $ML^{-2} T^{-2}, ML^{-1/3}$ (b) $M^2 L^4 T^{-2}, M^{1/3} L^{-1}$
(c) $M^2 L^{-2} T^{-2}, M^{1/3} L^{-1}$ (d) $M^2 L^{-2} T^{-2}, ML^{-3}$
12. The dimensions of intensity are
(a) $[L^0 M T^{-3}]$ (b) $[L^1 M^2 T^{-2}]$
(c) $[L^2 M T^{-2}]$ (d) $[L^2 M^2 T^{-3}]$
13. The dimensions of light year is
(a) T (b) $L T^{-1}$
(c) L (d) T^{-1}
14. The time dependence of a physical quantity P is given by $P = P_0 \exp(-\alpha t^2)$, where α is a constant and t is time, The constant α is
(a) dimensionless (b) has dimensions T^{-2}
(c) has dimensions of P (d) has dimensions T^2
15. Two quantities A and B have different dimensions. Which mathematical operation may be physically meaningful.
(a) A/B (b) $A+B$
(c) $A-B$ (d) $A = B$
16. Which one of the following pair of quantities has the same dimension?
(a) force and work done (b) momentum and impulse
(c) pressure and force (d) surface tension and force

17. A cube has a side of length 1.2×10^{-2} m. Calculate its volume.
- (a) $1.7 \times 10^{-6} \text{ m}^3$ (b) $1.73 \times 10^{-6} \text{ m}^3$
(c) $1.0 \times 10^{-6} \text{ m}^3$ (d) $1.732 \times 10^{-6} \text{ m}^3$
18. The equation of state for a real gas is given by $\left(P + \frac{a}{v^2}\right)(v - b) = RT$
the dimensions of constant a are
- (a) $[M L^5 T^{-2}]$ (b) $[M^{-1} L^5 T^2]$
(c) $[M L^{-5} T^{-1}]$ (d) $[M L^5 T^{-1}]$
19. The number of significant figures in 30.00 m are
- (a) 1 (b) 2
(c) 3 (d) 4
20. Which of the following measurements is most precise?
- (a) 5.00 m (b) 5.00 km
(c) 5.00 cm (d) 5.00 mm

Answer Key :

1. (d) 2. (b) 3. (c) 4. (c) 5. (a) 6. (b)
7. (c) 8. (c) 9. (c) 10. (c) 11. (c) 12. (a)
13. (c) 14. (b) 15. (a) 16. (b) 17. (a) 18. (a)
19. (d) 20. (d)

HINTS AND EXPLANATIONS :

2. $\omega t = \text{Angle} = \text{dimensionless}$

so dimension of $\omega = \frac{1}{t} = [M^0 L^0 T^{-1}]$

3. curie = unit of radioactivity

$$= \frac{dN}{dt} = \frac{\text{Number}}{\text{time}}$$

$$= [T^{-1}] \text{ or } [M^0 L^0 T^{-1}]$$

4. Surface tension and Tension have different dimension

$$\text{Tension} = \text{Force} = [\text{MLT}^{-2}]$$

$$\text{Surface tension} = \frac{\text{Force}}{\text{length}} = [\text{M T}^{-2}]$$

5. Energy = Force \times Length

$$= \frac{\text{change in momentum}}{\text{time}} \times \sqrt{\text{area}} = [\text{p A}^{1/2} \text{ A}^{-1}]$$

7. $v = k P^x \rho^y$

$$[\text{M}^0 \text{ L T}^{-1}] = [\text{M L}^{-1} \text{ T}^{-2}]^x [\text{M L}^{-3}]^y$$

$$0 = x + y, \quad 1 = -x - 3y, \quad -1 = -2x$$

$$y = -x \qquad \qquad \qquad x = 1/2$$

$$= -1/2$$

8. $\frac{\Delta\rho}{\rho} \times 100 = \frac{\Delta m}{m} \times 100 + \frac{\Delta v}{v} \times 100 = 2\% + 3\% = 5\%$

9. $\left[\frac{L}{L}\right] = a^n$

No dimension $1 = a^n$ Possible for $n = 0$

11. Dimension of $\beta^3 =$ dimension of density

Solve, $\beta = [\text{M}^{1/3} \text{L}^{-1}]$

$$\text{Force} = \frac{\alpha}{\text{density}}$$

$$\alpha = \text{Force} \times \text{density}$$

$$= [\text{M L T}^{-2} \text{ M L}^{-3}]$$

$$= [\text{M}^2 \text{ L}^{-2} \text{ T}^{-2}]$$

12. Intensity = $\frac{\text{energy}}{\text{area} \times \text{time}}$

$$= \left[\frac{\text{M L}^2 \text{ T}^{-2}}{\text{L}^2 \text{ T}} \right] = [\text{M T}^{-3}] = [\text{M L}^0 \text{T}^{-3}]$$

13. Light year = distance = L

14. $\alpha t^2 = \text{constant}$ $\alpha = \frac{1}{t^2} = [T^{-2}]$

16. Momentum and Impulse have same dimension = $[M L T^{-1}]$

17. Volume = (side)³ = $(1.2 \times 10^{-2})^3 = 1.728 \times 10^{-6} = 1.7 \times 10^{-6} \text{ m}^3$

18. Dimension of a = $PV^2 = [M L^{-1} T^{-2} L^6] = [M L^5 T^{-2}]$

20. 5.00 mm is most precise because it has least count.



Kinematic

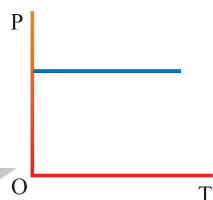

Unit - 2

2.1 Motion in One Dimension : Position

Position of any point is completely expressed by two factors : Its distance from the observer and its direction with respect to observer.

That is why position is characterised by a vector known as position vector.

Let point P is in a xy plane and its coordinates are (x, y) . Then position

vector (\vec{r}) of point will be $x\hat{i} + y\hat{j}$ and if the point P is in a space and its coordinates are (x, y, z) then position vector can be expressed as $\vec{r} = x\hat{i} + y\hat{j} + z\hat{k}$.

2.2 Rest and Motion

If a body does not change its position as time passes with respect to frame of reference, it is said to be at rest.

And if a body changes its position as time passes with respect to frame of reference, it is said to be in motion.

Frame of Reference : It is a system to which a set of coordinates are attached and with reference to which observer describes any event.

Rest and motion are relative terms. It depends upon the frame of references.

2.3 Types of Motion

One dimensional	Two dimensional	Three dimensional
Motion of a body in a straight line is called one dimensional motion.	Motion of body in a plane is called two dimensional motion.	Motion of body in a space is called three dimensional motion.
When only one coordinate of the position of a body changes with time then it is said to be moving one dimensionally.	When two coordinates of the position of a body changes with time then it is said to be moving two dimensionally.	When all three coordinates of the position of a body changes with time then it is said to be moving three dimensionally.

<p><i>e.g.</i>, Motion of car on a straight road.</p>	<p><i>e.g.</i>, Motion of car on a circular turn.</p>	<p><i>e.g.</i>, Motion of flying kite. Motion of flying insect.</p>
<p>Motion of freely falling body. Motion of billiards ball.</p>		

2.4 Distance and Displacement

(1) Distance : It is the actual path length covered by a moving particle in a given interval of time.

(i) Its a scalar quantity.

(ii) Dimension : $[M^0 L^1 T^0]$

(iii) Unit : metre (S. I.)

(2) Displacement : Displacement is the change in position vector *i.e.*, A vector joining initial to final position.

(i) Displacement is a vector quantity

(ii) Dimension : $[M^0 L^1 T^0]$

(iii) Unit : metre (S. I.)

(iv) If $\bar{S}_1, \bar{S}_2, \bar{S}_3, \dots, \bar{S}_n$ are the displacements of a body then the total (net) displacement is the vector sum of the individuals.

$$\bar{S} = \bar{S}_1 + \bar{S}_2 + \bar{S}_3 + \dots + \bar{S}_n$$

(3) Comparison between distance and displacement :

(i) Distance \geq Displacement.

(ii) For a moving particle distance can never be negative or zero while displacement can be *i.e.*, Distance > 0 but Displacement $> =$ or < 0 .

(iii) For motion between two points displacement is single valued while distance depends on actual path and so can have many values.

(iv) For a moving particle distance can never decrease with time while displacement can. Decrease in displacement with time means body is moving towards the initial position.

(v) In general magnitude of displacement is not equal to distance. However, it can be so if the motion is along a straight line without change in direction.

2.5 Speed and Velocity

(1) **Speed** : Rate of distance covered with time is called speed.

- (i) It is a scalar quantity having symbol v .
- (ii) Dimension : $[M^0L^1T^{-1}]$
- (iii) Unit : metre/second (S.I.), cm/second (C. G. S.)
- (iv) Types of speed :

- (a) **Uniform speed** : When a particle covers equal distances in equal intervals of time, (no matter how small the intervals are) then it is said to be moving with uniform speed.
- (b) **Non-uniform (variable) speed** : In non-uniform speed particle covers unequal distances in equal intervals of time.
- (c) **Average speed** : The average speed of a particle for a given 'Interval of time' is defined as the ratio of distance travelled to the time taken.

$$\text{Average speed} = \frac{\text{Distance travelled}}{\text{Time taken}}; V_{av} = \frac{\Delta s}{\Delta t}$$

- **Time average speed** : When particle moves with different uniform speed v_1, v_2, v_3, \dots etc. in different time intervals t_1, t_2, t_3, \dots etc. respectively, its average speed over the total time of journey is given as

$$V_{av} = \frac{\text{Total distance covered}}{\text{Total time elapsed}} = \frac{d_1 + d_2 + d_3 + \dots}{t_1 + t_2 + t_3 + \dots}$$
$$= \frac{v_1 t_1 + v_2 t_2 + v_3 t_3 + \dots}{t_1 + t_2 + t_3 + \dots}$$

Special case : When particle moves with speed v_1 upto half time of its total motion and in rest time it is moving with speed v_2 then

$$V_{av} = \frac{V_1 + V_2}{2}.$$

- **Distance averaged speed** : When a particle describes different distances d_1, d_2, d_3, \dots with different time intervals t_1, t_2, t_3, \dots with speeds v_1, v_2, v_3, \dots respectively then the speed of particle averaged over the total distance can be given as

$$V_{av} = \frac{\text{Total distance covered}}{\text{Total time elapsed}} = \frac{d_1 + d_2 + d_3 + \dots}{t_1 + t_2 + t_3 + \dots}$$

$$= \frac{d_1 + d_2 + d_3 + \dots}{\frac{d_1}{v_1} + \frac{d_2}{v_2} + \frac{d_3}{v_3} + \dots}$$

- (d) **Instantaneous speed** : It is the speed of a particle at particular instant. When we say “speed”, it usually means instantaneous speed.

The instantaneous speed is average speed for infinitesimally small time interval (*i.e.* $\Delta t \rightarrow 0$). Thus

$$\text{Instantaneous speed } v = \lim_{\Delta t \rightarrow 0} \frac{\Delta s}{\Delta t} = \frac{ds}{dt}$$

- (2) **Velocity** : Rate of change of position *i.e.*, rate of displacement with time is called velocity.

- (i) It is a vector quantity having symbol v .
- (ii) Dimension : $[M^0 L^1 T^{-1}]$
- (iii) Unit : metre/second (S. I.), cm/second (C. G. S.)
- (iv) Types

- (a) **Uniform velocity** : A particle is said to have uniform velocity, if magnitudes as well as direction of its velocity remains same and this is possible only when the particles moves in same straight line without reversing its direction.
- (b) **Non-uniform velocity** : A particle is said to have non-uniform velocity, if either of magnitude or direction of velocity changes (or both changes).
- (c) **Average velocity** : It is defined as the ratio of displacement to time taken by the body

$$\text{Average velocity} = \frac{\text{Displacement}}{\text{Time taken}}; v_{av} = \frac{\vec{\Delta r}}{\Delta t}$$

- (d) **Instantaneous velocity** : Instantaneous velocity is defined as rate of change of position vector of particles with time at a certain instant of time.

$$\text{Instantaneous velocity } v = \lim_{t \rightarrow 0} \frac{\vec{\Delta r}}{\Delta t} = \frac{dr}{dt}$$

- (v) Comparison between instantaneous speed and instantaneous velocity
- Instantaneous velocity is always tangential to the path followed by the particle.
 - A particle may have constant instantaneous speed but variable instantaneous velocity.
 - The magnitude of instantaneous velocity is equal to the instantaneous speed.
 - If a particle is moving with constant velocity then its average velocity and instantaneous velocity are always equal.
 - If displacement is given as a function of time, then time derivative of displacement will give velocity.
- (vi) Comparison between average speed and average velocity
- Average speed is scalar while average velocity is a vector both having same units (m/s) and dimensions $[LT^{-1}]$.
 - Average speed or velocity depends on time interval over which it is defined.
 - For a given time interval average velocity is single valued while average speed can have many values depending on path followed.
 - If after motion body comes back to its initial position then $\vec{v}_{av} = \vec{0}$ (as $\Delta r = 0$) but $v_{av} > 0$ and finite as ($\Delta s > 0$).
 - For a moving body average speed can never be negative or zero (unless $t \rightarrow \infty$) while average velocity can be *i.e.*, $v_{av} > 0$ while $\vec{v}_{av} =$ or < 0 .

2.6 Acceleration

The time rate of change of velocity of an object is called acceleration of the object.

- It is a vector quantity. It's direction is same as that of change in velocity (not of the velocity)
- There are three possible ways by which change in velocity may occur

When only direction of velocity changes	When only magnitude of velocity changes	When both magnitude and direction of velocity changes
Acceleration perpendicular to velocity	Acceleration parallel or anti-parallel to velocity	Acceleration has two components one is perpendicular to velocity and another parallel or antiparallel to velocity
<i>e.g.</i> Uniform circular motion	<i>e.g.</i> Motion under gravity	<i>e.g.</i> Projectile motion

(3) Dimension : $[M^0 L^1 T^{-2}]$

(4) Unit : metre/second² (S. I.); cm/second² (C. G. S.)

(5) Types of acceleration :

(i) **Uniform acceleration** : A body is said to have uniform acceleration if magnitude and direction of the acceleration remains constant during particle motion.

- If a particle is moving with uniform acceleration, this does not necessarily imply that particles is moving in straight line, *e.g.*, Projectile motion.

(ii) **Non-uniform acceleration** : A body is said to have non-uniform acceleration, if magnitude or direction or both, change during motion.

(iii) **Average acceleration** :
$$\vec{a}_{av} = \frac{\vec{\Delta v}}{\Delta t} = \frac{\vec{v}_2 - \vec{v}_1}{\Delta t}$$

The direction of average acceleration vector is the direction of the

change in velocity vector as
$$\vec{a} = \frac{\vec{\Delta v}}{\Delta t}$$

(iv) **Instantaneous acceleration** =
$$\vec{a} = \lim_{\Delta t \rightarrow 0} \frac{\vec{\Delta v}}{\Delta t} = \frac{d\vec{v}}{dt}$$

(v) For a moving body there is no relation between the direction of instantaneous velocity and direction of acceleration.

e.g. (a) In uniform circular motion $\theta = 90^\circ$ always (b) in a projectile motion θ is variable for every point of trajectory.

(vi) By definition,
$$\vec{a} = \frac{d\vec{v}}{dt} = \frac{d^2x}{dt^2} \left[\text{As } \vec{v} = \frac{dx}{dt} \right]$$

(vii) If velocity is given as a function of position, then by chain rule

$$a = \frac{dv}{dt} = \frac{dv}{dx} \times \frac{dx}{dt} = v \times \frac{dv}{dx} \left[\text{as } v = \frac{dx}{dt} \right]$$

(viii) If a particle is accelerated for a time t_1 by acceleration a_1 and for time t_2 by acceleration a_2 then average acceleration is

$$a_{av} = \frac{a_1 t_1 + a_2 t_2}{t_1 + t_2}$$

(ix) Acceleration can be positive, zero or negative. Positive acceleration means velocity increasing with time, zero acceleration means velocity is uniform constant while negative acceleration (retardation) means velocity is decreasing with time.

(x) For motion of a body under gravity, acceleration will be equal to 'g', where g is the acceleration due to gravity. Its normal value is 9.8 m/s^2 or 980 cm/s^2 or 32 feet/s^2 .

2.7 Position Time Graph

Various position-time graphs and their interpretation

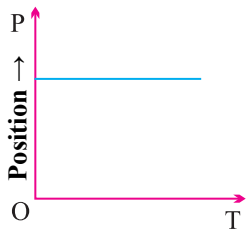

$$\theta = 0^\circ \text{ so } v = 0$$

i.e., line parallel to time axis represents that the particle is at rest.

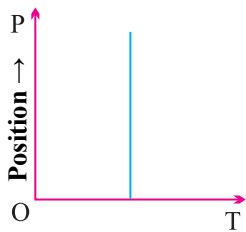

$$\theta = 90^\circ \text{ so } v = \infty$$

i.e., line perpendicular to time axis represents that particle is changing its position but time does not changes it means the particle possesses infinite velocity.

Practically this is not possible.

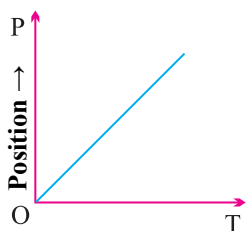

$$\theta = \text{constant so } v = \text{constant, } a = 0$$

i.e., line with constant slope represents uniform velocity of the particle.

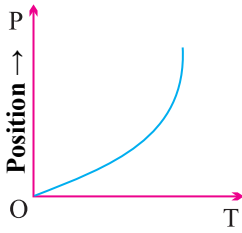

θ is increasing so v is increasing, a is positive.
i.e., line bending towards position axis represents increasing velocity of particle. It means the particle possesses acceleration.

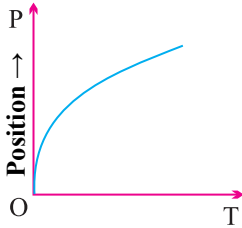

θ is decreasing so v is decreasing, a is negative.
i.e., line bending towards time axis represents decreasing velocity of the particle. It means the particle possesses retardation.

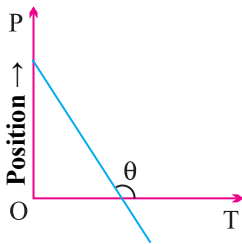

θ constant but $> 90^\circ$ so v will be constant but negative.
i.e., line with negative slope represent that particle returns towards the point of reference, (negative displacement).

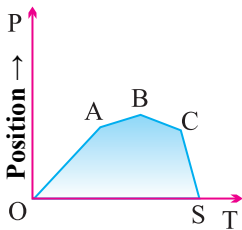

Straight line segments of different slopes represent that velocity of the body changes after certain interval of time.

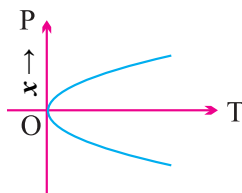

This graph shows that at one instant the particle has two positions. Which is not possible.

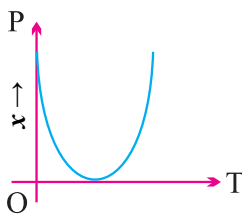

The graph shows that particle coming towards origin initially and after that it is moving away from origin.

Note :

- If the graph is plotted between distance and time then it is always an increasing curve and it never comes back towards origin because distance.
- For two particles having displacement time graph with slope θ_1 and θ_2 possesses velocities v_1 and v_2 respectively then $\frac{v_1}{v_2} = \frac{\tan \theta_1}{\tan \theta_2}$.

2.8 Velocity Time Graph

The graph is plotted by taking time t along x axis and velocity of the particle on y axis.

Distance and displacement : The area covered between the velocity time graph and time axis gives the displacement and distance travelled by the body for a given time interval.

Then Total distance = Addition of modulus of different area.

$$i.e. \quad s = \int |v| dt$$

Total displacement = Addition of different area considering their sign.

$$i.e., \quad r = \int v dt$$

Acceleration : It is clear that slope of velocity-time graph represents the acceleration of the particle.

Various position-time graphs and their interpretation

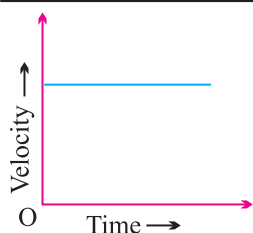

$\theta = 0, a = 0, v = \text{constant}$

i.e., line parallel to time axis represents that the particle is moving with constant velocity.

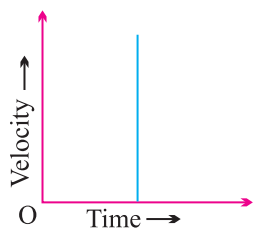

$\theta = 90^\circ, a = \infty, v = \text{increasing}$

i.e., line perpendicular to time axis represents that particle is increasing its velocity but time does not change. It means the particle possesses infinite acceleration. Practically it is not possible.

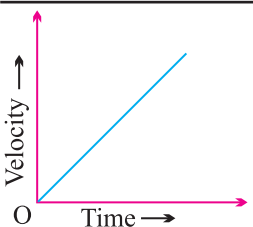

$\theta = \text{constant}, \text{ so } a = \text{constant and } v \text{ is increasing uniformly with time}$

i.e., line with constant slope represents uniform acceleration of the particle.

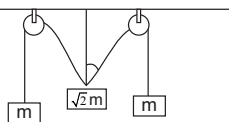

θ is increasing so acceleration increasing

i.e., line bending towards velocity axis represents the increasing acceleration in the body.

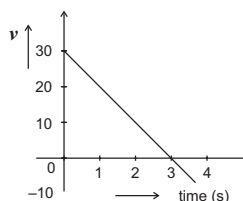

θ is decreasing so acceleration decreasing

i.e., line bending towards time axis represents the decreasing acceleration in the body.

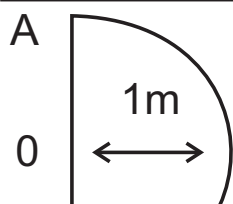

Positive constant acceleration because θ is constant and $< 90^\circ$ but initial velocity of the particle is negative.

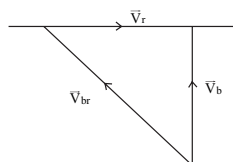

Positive constant acceleration because θ is constant and $< 90^\circ$ but initial velocity of the particle is positive.

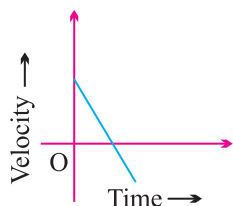

Negative constant acceleration because θ is constant and $> 90^\circ$ but initial velocity of the particle is positive

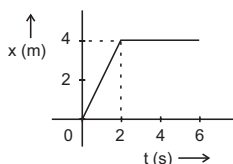

Negative constant acceleration because θ is constant and $> 90^\circ$ but initial velocity of the particle is zero.

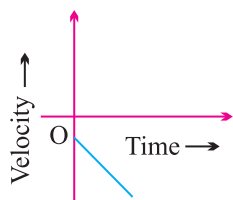

Negative constant acceleration because θ is constant and $> 90^\circ$ but initial velocity of the particle is negative.

2.9 Equations of Kinematics

These are the various relations between u , v , a , t and s for the moving particle where the notations are used as :

u = Initial velocity of the particle at time $t = 0$ sec

v = Final velocity at time t sec

a = Acceleration of the particle

s = Distance travelled in time t sec

s_n = Distance travelled by the body in n^{th} sec

(1) When particle moves with constant acceleration

(i) Acceleration is said to be constant when both the magnitude and direction of acceleration remain constant.

(ii) There will be one dimensional motion if initial velocity and acceleration are parallel or anti-parallel to each other.

(iii) Equations of motion in scalar form	Equation of motion in vector form
--	-----------------------------------

$$v = u + at$$

$$\vec{v} = \vec{u} + \vec{a}t$$

$$s = ut + \frac{1}{2}at^2$$

$$\vec{s} = \vec{u}t + \frac{1}{2}\vec{a}t^2$$

$$v^2 = u^2 + 2as$$

$$\vec{v} \cdot \vec{v} - \vec{u} \cdot \vec{u} = 2\vec{a} \cdot \vec{s}$$

$$s = \left(\frac{u + v}{2}\right)t$$

$$\vec{s} = \frac{1}{2}(\vec{u} + \vec{v})t$$

$$s_n = u + \frac{a}{2}(2n - 1)$$

$$\vec{s}_n = \vec{u} + \frac{\vec{a}}{2}(2n - 1)$$

(2) Important points for uniformly accelerated motion

(i) If a body starts from rest and moves with uniform acceleration then distance covered by the body in t sec is proportional to t^2 (i.e., $s \propto t^2$).

So the ratio of distance covered in 1 sec, 2 sec and 3 sec is $1^2 : 2^2 : 3^2$ or $1 : 4 : 9$.

(ii) If a body starts from rest and moves with uniform acceleration then distance covered by the body in n^{th} sec is proportional to $(2n - 1)$ (i.e. $s_n \propto (2n - 1)$).

So the ratio of distance covered in I sec, II sec and III sec is I : 3 : 5.

- (iii) A body moving with a velocity u is stopped by application of brakes after covering a distance s . If the same body moves with velocity nu and same braking force is applied on it then it will come to rest after covering a distance of $n^2 s$.

2.10 Motion of Body Under Gravity (Free Fall)

Acceleration produced in the body by the force of gravity, is called acceleration due to gravity. It is represented by the symbol g .

In the absence of air resistance, it is found that all bodies fall with the same acceleration near the surface of the earth. This motion of a body falling towards the earth from a small altitude ($h \ll R$) is called free fall.

An ideal one-dimensional motion under gravity in which air resistance and the small changes in acceleration with height are neglected.

PROJECTILE MOTION

2.11 Introduction

If the force acting on a particle is oblique with initial velocity then the motion of particle is called projectile motion.

2.12 Projectile

A body which is in flight through the atmosphere but is not being propelled by any fuel is called projectile.

2.13 Assumptions of Projectile Motion

- (1) There is no resistance due to air.
- (2) The effect due to curvature of earth is negligible.
- (3) The effect due to rotation of earth is negligible.
- (4) For all points of the trajectory, the acceleration due to gravity 'g' is constant in magnitude and direction.

2.14 Principles of Physical Independence of Motions

- (1) The motion of a projectile is a two-dimensional motion. So, it can be discussed in two parts. Horizontal motion and vertical motion. These two motions take place independent of each other. This is called the principle

of physical independence of motions.

- (2) The velocity of the particle can be resolved into two mutually perpendicular components. Horizontal component and vertical component.
- (3) The horizontal component remains unchanged throughout the flight. The force of gravity continuously affects the vertical component.
- (4) The horizontal motion is a uniform motion and the vertical motion is a uniformly accelerated retarded motion.

2.15 Types of Projectile Motion

- (1) Oblique projectile motion
- (2) Horizontal projectile motion
- (3) Projectile motion on an inclined plane

2.16 Oblique Projectile

In projectile motion, horizontal component of velocity ($u \cos \theta$), acceleration (g) and mechanical energy remains constant while, speed, velocity, vertical component of velocity ($u \sin \theta$), momentum kinetic energy and potential energy all changes. Velocity, and KE are maximum at the point of projection while minimum (but not zero) at highest point.

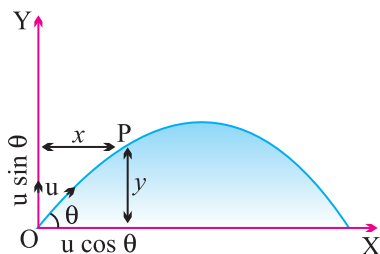

- (1) **Equation of trajectory :** A projectile thrown with velocity u at an angle θ with the horizontal. The velocity u can be resolved into two rectangular components $u \cos \theta$ component along X-axis and $u \sin \theta$ component along Y-axis.

$$y = x \tan \theta - \frac{1}{2} \frac{gx^2}{u^2 \cos^2 \theta}$$

Note :

- Equation of oblique projectile also can be written as

$$y = x \tan \theta \left[1 - \frac{x}{R} \right]$$

(where R = horizontal range)

- (2) **Displacement of projectile** (\vec{r}) : Let the particle acquires a position

P having the coordinates (x, y) just after time t from the instant of projection.

The corresponding position vector of the particle at time t is \vec{r} shown in the figure.

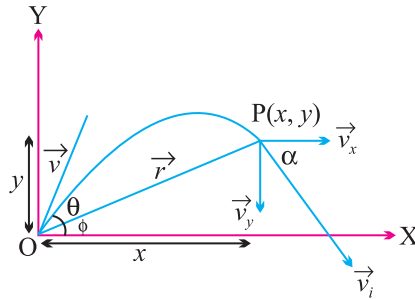

$$\vec{r} = x \hat{i} + y \hat{j} \quad \dots(i)$$

The horizontal distance covered during time t given as

$$x = v_x t \Rightarrow x = u \cos \theta t \quad \dots(ii)$$

The vertical velocity of the particle at time t is given as

$$y = u \sin \theta t - \frac{1}{2} g t^2 \quad \dots(iii)$$

and $\phi = \tan^{-1}(y/x)$

Note :

- The angle of elevation ϕ of the highest point of the projectile and the angle of projection θ are related to each other as $\tan \phi = \frac{1}{2} \tan \theta$.

(3) **Instantaneous velocity \mathbf{v} :** In projectile motion, vertical component of velocity changes but horizontal component of velocity remains always constant.

Let v_i be the instantaneous velocity of projectile at time t direction of this velocity is along the tangent to the trajectory at point P.

$$\vec{v}_i = v_x \hat{i} + v_y \hat{j} \Rightarrow v_i = \sqrt{v_x^2 + v_y^2}$$

Direction of instantaneous velocity $\tan \alpha = \frac{v_y}{v_x} = \frac{u \sin \theta - gt}{u \cos \theta}$.

(7) **Time of flight :** The total time taken by the projectile to go up and come down to the same level from which it was projected is called time of flight.

For vertical upward motion

$$0 = u \sin \theta - gt \Rightarrow t = (u \sin \theta / g)$$

$$\text{Time of flight } T = 2t = \frac{2u \sin \theta}{g}$$

- (8) **Horizontal range** : It is the horizontal distance travelled by a body during the time of flight. So by using second equation of motion

$$R = u \cos \theta \times T = u \cos \theta \times (2u \sin \theta / g) = \frac{u^2 \sin 2\theta}{g}$$

$$R = \frac{u^2 \sin 2\theta}{g}$$

If angle of projection is changed from θ to $\theta' = (90 - \theta)$ then range remains unchanged. These angles are called complementary angle of projection.

- (iv) **Maximum range** : For range to be maximum $\frac{dR}{d\theta} = 0 \Rightarrow \frac{d}{d\theta} \left[\frac{u^2 \sin 2\theta}{g} \right] = 0$, a projectile will have maximum range when it is projected at an angle of 45° to the horizontal and the maximum range will be (u^2/g) .

When the range is maximum, the height H reached by the projectile

$$H = \frac{u^2 \sin^2 \theta}{2g} = \frac{u^2 \sin^2 45}{2g} = \frac{u^2}{4g} = \frac{R_{\max}}{4}$$

- (v) **Relation between horizontal range and maximum height** :

$$R = 4H \cot \theta$$

If $R = 4H \cot \theta = \tan^{-1} (1)$ or $\theta = 45^\circ$.

- (9) **Maximum height** : It is the maximum height from the point of projection, a projectile can reach.

So, by using $v^2 = u^2 + 2as$

$$0 = (u \sin \theta)^2 - 2gH$$

$$H = \frac{u^2 \sin^2 \theta}{2g}$$

- (i) $H_{\max} = \frac{u^2}{2g}$ (when $\sin^2 \theta = \max = 1$ i.e., $\theta = 90^\circ$)

i.e., for maximum height body should be projected vertically upward.

- (10) Motion of a projectile as observed from another projectile is a straight line.

2.17 Horizontal Projectile

A body be projected horizontally from a certain height 'y' vertically above

the ground with initial velocity u . If friction is considered to be absent then there is no other horizontal force which can affect the horizontal motion. The horizontal velocity therefore remains constant.

- (4) **Time of flight :** If a body is projected horizontally from a height h with velocity u and time taken by the body to reach the ground is T , then

$$T = \sqrt{\frac{2h}{g}}$$

- (5) **Horizontal range :** Let R is the horizontal distance travelled by the body

$$R = u \sqrt{\frac{2h}{g}}$$

- (6) If projectiles A and B are projected horizontally with different initial velocity from same height and third particle C is dropped from same point then

- (i) All three particles will take equal time to reach the ground.
- (ii) Their net velocity would be different but all three particle possess same vertical component of velocity.
- (iii) The trajectory of projectiles A and B will be straight line *w.r.t.* particle C.

- (7) If various particles thrown with same initial velocity but indifferent direction then

- (i) They strike the ground with same speed at different times irrespective of their initial direction of velocities.
- (ii) Time would be least for particles which was thrown vertically downward.
- (iii) Time would be maximum for particle A which was thrown vertically upward.

CIRCULAR MOTION

Circular motion is another example of motion in two dimensions. To create circular motion in a body it must be given some initial velocity and a force must then act on the body which is always directed at right angles to instantaneous velocity.

Circular motion can be classified into two types-Uniform circular motion and non-uniform circular motion.

2.18 Variables of Circular Motion

(1) **Displacement and distance** : When particle moves in a circular path describing an angle θ during time t (as shown in the figure) from the position A to the position B, we see that the magnitude of the position vector r (that is equal to the radius of the circle) remains constant, *i.e.*, $|\vec{r}_1| = |\vec{r}_2| = r$ and the direction of the position vector changes from time to time.

(i) **Displacement** : The change of position vector or the displacement $\Delta\vec{r}$ of the particle from position A to position B is given by referring the figure.

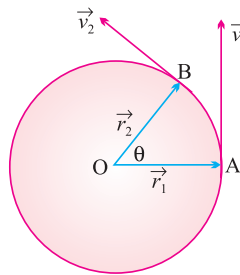

$$\Delta\vec{r} = \vec{r}_2 - \vec{r}_1$$

$$\Delta r = 2r \sin \frac{\theta}{2}$$

(ii) **Distance** : The distance covered by the particle during the time t is given as $d =$ length of the arc AB

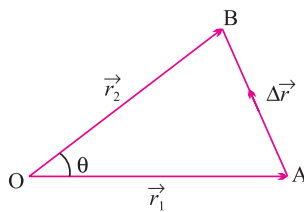

(2) **Angular displacement (θ)** : The angle turned by a body moving on a circle from some reference line is called angular displacement.

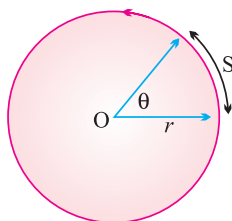

- (i) Dimension = $[M^0L^0T^0]$ (as $\theta = \text{arc}/\text{radius}$).
- (ii) Units = Radian or Degree. It is some times also specified in terms of fraction or multiple of revolution.
- (iii) $2\pi \text{ rad} = 360^\circ = 1 \text{ Revolution}$
- (iv) Angular displacement is a axial vector quantity. Its direction depends upon the sense of rotation of the object can be given by Right Hand Rule; which states that if the curvature of the fingers of right hand represents the sense of rotation of the object, then the thumb, held perpendicular to the curvature of the fingers, represents the direction of angular displacement vector.
- (v) Relation between linear displacement and angular displacement

$$\vec{s} = \vec{\theta} \times \vec{r} \text{ or } s = r\theta.$$

(3) Angular velocity (ω) : Angular velocity of an object in circular motion is defined as the time rate of change of its angular displacement.

(i) Angular velocity $\omega = \frac{\text{angle traced}}{\text{time taken}} = \lim_{\Delta t \rightarrow 0} \frac{\Delta\theta}{\Delta t} = \frac{d\theta}{dt}$

$$\omega = \frac{d\theta}{dt}$$

- (ii) Dimension : $[M^0 L^0 T^{-1}]$
- (iii) Units : Radians per second (rad. s^{-1}) or Degree per second.
- (iv) Angular velocity is an axial vector. Its direction is the same as that of $\Delta\theta$.
- (v) Relation between angular velocity and linear velocity $\vec{v} = \vec{\omega} \times \vec{r}$.
- (vi) For uniform circular motion ω remains constant where as for non-uniform motion ω varies with respect to time.

(4) Change in velocity : We want to know the magnitude and direction of the change in velocity of the particle which is performing uniform circular motion as it moves from A to B during time t as shown in figure. The change in velocity vector is given as

$$\Delta\vec{v} = \vec{v}_2 - \vec{v}_1$$

$$\Delta v = 2v \sin \frac{\theta}{2}$$

- Relation between linear velocity and angular velocity. In vector form

$$\vec{v} = \vec{\omega} \times \vec{r}$$

- (5) **Time period (T)** : In circular motion, the time period is defined as the time taken by the object to complete one revolution on its circular path.
- (6) **Frequency (n)** : In circular motion, the frequency is defined as the number of revolutions completed by the object on its circular path in a unit time.
- (i) Units : s^{-1} or hertz (Hz).
- (ii) Dimension : $[M^0L^0T^{-1}]$

Note :

- Relation between time period and frequency :

$$\therefore T = 1/n$$

- Relation between angular velocity, frequency and time period :

$$\omega = \frac{2\pi}{T} = 2\pi n$$

- (7) **Angular acceleration (α)** : Angular acceleration of an object in circular motion is defined as the time rate of change of its angular velocity.

(i) $\alpha = \lim_{\Delta t \rightarrow 0} \frac{\Delta\omega}{\Delta t} = \frac{d\omega}{dt} = \frac{d^2\theta}{dt^2}$

(ii) Units : $rad\ s^{-2}$

(iii) Dimension : $[M^0 L^0 T^{-2}]$

- (iv) Relation between linear acceleration and angular acceleration

$$\vec{a} = \vec{\alpha} \times \vec{r}$$

(v) For uniform circular motion since θ is constant so $\alpha = \frac{d\omega}{dt} = 0$.

(vi) For non-uniform circular motion $\alpha \neq 0$.

2.19 Centripetal Acceleration

- (1) Acceleration acting on the object undergoing uniform circular motion is called centripetal acceleration.
- (2) It always acts on the object along the radius towards the centre of the circular path.
- (3) Magnitude of centripetal acceleration $\alpha = \frac{v^2}{r} = \omega^2 r = 4\pi n^2 r = \frac{4\pi^2}{T^2} r$.

- (4) Direction of centripetal acceleration : It is always the same as that of $\Delta \vec{v}$.

2.20 Centripetal Force

According to Newton's first law of motion, whenever a body moves in a straight line with uniform velocity, no force is required to maintain this velocity. But when a body moves along a circular path with uniform speed, its direction changes continuously *i.e.*, velocity keeps on changing on account of a change in direction. According to Newton's second law of motion, a change in the direction of motion of the body can take place only if some external force acts on the body.

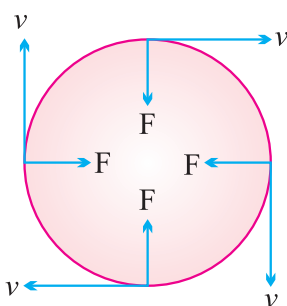

Due to inertia, at every point of the circular path; the body tends to move along the tangent to the circular path at that point (in figure). Since every body has directional inertia, a velocity cannot change by itself and as such we have to apply a force. But this force should be such that it changes the direction of velocity and not its magnitude. This is possible only if the force acts perpendicular to the direction of velocity. Because the velocity is along the tangent, this force must be along the radius (because the radius of a circle at any point is perpendicular to the tangent at that point).

Further, as this force is to move the body in a circular path, it must act towards the centre. The centre-seeking force is called the centripetal force.

Hence, centripetal force is that force which is required to move a body in a circular path with uniform speed. The force acts on the body along the radius and towards centre.

- (1) Formulae for centripetal force :

$$F = \frac{mv^2}{r} = m\omega^2 r = m4\pi^2 n^2 r = \frac{m4\pi^2 r}{T^2}$$

- (2) Centripetal force in different situation

Situation	Centripetal Force
A particle tied to a string and whirled in a horizontal circle.	Tension in the string.
Vehicle taking a turn on a level road.	Frictional force exerted by the road on the tyres.
A vehicle on a speed breaker.	Weight of the body or a component of weight.
Revolution of earth around the sun.	Gravitational force exerted by the sun.
Electron revolving around the nucleus in an atom.	Coulomb attraction exerted by the protons in the nucleus.
A charged particle describing a circular path in a magnetic field.	Magnetic force exerted by the agent that sets up the magnetic field.

2.21 Centrifugal Force

It is an imaginary force due to incorporated effects of inertia. Centrifugal force is a fictitious force which has significance only in a rotating frame of reference.

2.22 Work done by Centripetal Force

The work done by centripetal force is always zero as it is perpendicular to velocity and hence instantaneous displacement.

Example :

- (i) When an electron revolve around the nucleus in hydrogen atom in a particular orbit, it neither absorb nor emit any energy means its energy remains constant.
- (ii) When a satellite established once in a orbit around the earth and it starts revolving with particular speed, then no fuel is required for its circular motion.

2.23 Skidding of Vehicle on a Level Road

When a vehicle turns on a circular path it requires centripetal force. If friction provides this centripetal force then vehicle can move in circular path safely if Friction force \geq Required centripetal force

$$\mu mg \geq \frac{mv^2}{r}$$

$$\therefore v_{safe} \leq \sqrt{\mu rg}$$

This is the maximum speed by which vehicle can turn in a circular path of radius r , where coefficient of friction between the road and tyre is μ .

2.24 Skidding of Object on a Rotating Platform

On a rotating platform, to avoid the skidding of an object (mass m) placed at a distance r from axis of rotation, the centripetal force should be provided by force of friction. Centripetal force = Force of friction

$$m\omega^2 r = \mu mg$$

$$\therefore \omega_{\max} = \sqrt{(\mu g / r)},$$

Hence maximum angular velocity of rotation of the platform is $\sqrt{(\mu g / r)}$, so that object will not skid on it.

2.25 Bending of a Cyclist

A cyclist provides himself the necessary centripetal force by leaning inward on a horizontal track, while going round a curve. Consider a cyclist of weight mg taking a turn of radius r with velocity v . In order to provide the necessary centripetal force, the cyclist leans through angle θ inwards as shown in figure.

$$R \sin \theta = \frac{mv^2}{r} \quad \dots(i)$$

and $R \cos \theta = mg \quad \dots(ii)$

Dividing equation (i) by (ii), we have

$$\tan \theta = \frac{v^2}{rg} \quad \dots(iii)$$

Note :

- For the same reasons, an ice skater or an aeroplane has to bend inwards, while taking a turn.

2.26 Banking of a Road

For getting a centripetal force cyclist bend towards the centre of circular path but it is not possible in case of four wheelers.

Therefore, outer bed of the road is raised so that a vehicle moving on it gets automatically inclined towards the centre.

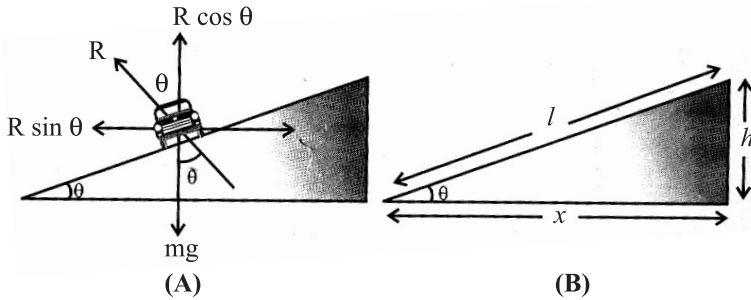

$$\tan \theta = \frac{v^2}{rg} \quad \dots(\text{iii})$$

If l = width of the road, h = height of the outer edge from the ground level then from the

$$\tan \theta = \frac{\omega^2 r}{g} = \frac{v\omega}{rg} \quad [\text{As } v = r\omega] \quad \dots(\text{iv})$$

If l = width of the road, h = height of the outer edge from the ground level then from the figure (B)

$$\tan \theta = \frac{h}{x} = \frac{h}{l}, \quad [\text{since } \theta \text{ is very small}] \quad \dots (\text{v})$$

- Maximum safe speed on a banked frictional road

$$v = \sqrt{\frac{rg(\mu + \tan \theta)}{1 - \mu \tan \theta}}$$

KINEMATICS (1 Mark)

1. Under what condition is the average velocity equal the instantaneous velocity ?
2. Draw Position time graph of two objects, A & B moving along a straight line, when their relative velocity is zero.

3. Suggest a situation in which an object is accelerated and have constant speed.
4. Two balls of different masses are thrown vertically upward with same initial velocity. Maximum heights attained by them are h_1 and h_2 respectively what is h_1/h_2 ?
5. A car moving with velocity of 50 kmh^{-1} on a straight road is ahead of a jeep moving with velocity 75 kmh^{-1} . How would the relative velocity be altered if jeep is ahead of car ?
6. Which of the two-linear velocity or the linear acceleration gives the direction of motion of a body ?
7. Will the displacement of a particle change on changing the position of origin of the coordinate system ?
8. If the instantaneous velocity of a particle is zero, will its instantaneous acceleration be necessarily zero ?
9. A projectile is fired with Kinetic energy 1 KJ. If the range is maximum, what is its Kinetic energy, at the highest point ?
10. Write an example of zero vector.
11. State the essential condition for the addition of vectors.
12. When is the magnitude of $(\vec{A} + \vec{B})$ equal to the magnitude of $(\vec{A} - \vec{B})$?
13. What is the maximum number of component into which a vector can be resolved ?
14. A body projected horizontally moves with the same horizontal velocity although it moves under gravity. Why ?
15. What is the angle between velocity and acceleration at the highest point of a projectile motion ?
16. When does (i) height attained by a projectile maximum ? (ii) horizontal range is maximum ?
17. What is the angle between velocity vector and acceleration vector in uniform circular motion ?

18. A particle is in clockwise uniform circular motion the direction of its acceleration is radially inward. If sense of rotation or particle is anticlockwise then what is the direction of its acceleration ?
19. A train is moving on a straight track with acceleration a . A passenger drops a stone. What is the acceleration of stone with respect to passenger ?
20. What is the average value of acceleration vector in uniform circular motion over one cycle ?
21. Does a vector quantity depends upon frame of reference chosen ?
22. What is the angular velocity of the hour hand of a clock ?
23. What is the source of centripetal acceleration for earth to go round the sun ?
24. What is the unit vector perpendicular to the plane of vectors \vec{A} and \vec{B} ? If $\vec{A} = \hat{i} + 2\hat{j} - \hat{k}$ and $\vec{B} = 2\hat{i} + \hat{k}$, find a unit vector perpendicular to plane of \vec{A} and \vec{B} .
25. What is the angle between $(\vec{A} + \vec{B})$ and $(\vec{A} - \vec{B})$?

2 Marks

26. What are positive and negative acceleration in straight line motion ?
27. Can a body have zero velocity and still be accelerating ? If yes gives any situation.
28. The displacement of a body is proportional to t^3 , where t is time elapsed. What is the nature of acceleration -time graph of the body ?
29. Suggest a suitable physical situation for the following graph.

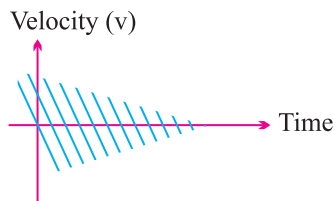

30. An object is in uniform motion along a straight line, what will be position time graph for the motion of object, if
 - (i) $x_0 = \text{positive}$, $v = \text{negative}$ $|\vec{v}|$ is constant.

- (ii) both x_0 and v are negative $|v|$ is constant.
- (iii) $x_0 = \text{negative}$, $v = \text{positive}$ $\left| \vec{v} \right|$ is constant.
- (iv) both x_0 and v are positive $\left| \vec{v} \right|$ is constant.
- where x_0 is position at $t = 0$.

31. A cyclist starts from centre O of a circular park of radius 1 km and moves along the path OPRQO as shown. If he maintains constant speed of 10 ms^{-1} . What is his acceleration at point R in magnitude & direction ?

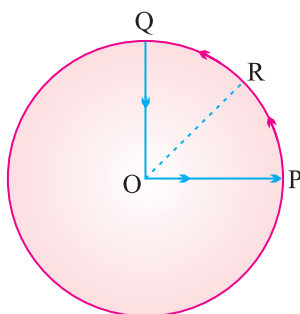

32. What will be the effect on horizontal range of a projectile when its initial velocity is doubled keeping angle of projection same ?
33. The greatest height to which a man can throw a stone is h . What will be the greatest distance upto which he can throw the stone ?
34. A person sitting in a train moving at constant velocity throws a ball vertically upwards. How will the ball appear to move to an observer.
- (i) Sitting inside the train
- (ii) Standing outside the train
35. A gunman always keep his gun slightly tilted above the line of sight while shooting. Why ?
36. Is the acceleration of a particle in circular motion not always towards the centre. Explain.

3 Marks

37. Draw (a) acceleration - time (b) velocity - time (c) Position - time graphs representing motion of an object under free fall. Neglect air resistance.
38. The velocity time graph for a particle is shown in figure. Draw acceleration time graph from it.

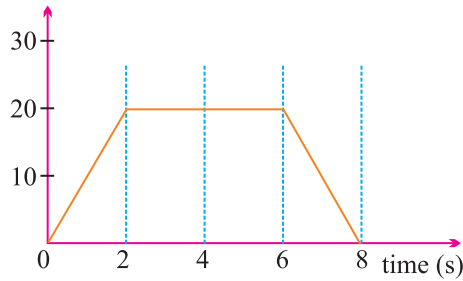

39. For an object projected upward with a velocity v_0 , which comes back to the same point after some time, draw
- Acceleration-time graph
 - Position-time graph
 - Velocity time graph
40. The acceleration of a particle in ms^{-2} is given by $a = 3t^2 + 2t + 2$, where time t is in second.
- If the particle starts with a velocity $v = 2 \text{ ms}^{-1}$ at $t = 0$, then find the velocity at the end of 2 s.
41. At what angle do the two forces $(P + Q)$ and $(P - Q)$ act so that the resultant is $\sqrt{3P^2 + Q^2}$.
42. Establish the following vector inequalities :
- $|\vec{a} + \vec{b}| \leq |\vec{a}| + |\vec{b}|$
 - $|\vec{a} + \vec{b}| \geq |\vec{a}| - |\vec{b}|$
43. A body is projected at an angle θ with the horizontal. Derive an expression for its horizontal range. Show that there are two angles θ_1 and θ_2 projections for the same horizontal range, such that $\theta_1 + \theta_2 = 90^\circ$.
44. Prove that the maximum horizontal range is four times the maximum height attained by the projectile, when fired at an inclination so as to have maximum range.
45. Show that there are two values of time for which a projectile is at the same height. Also show that the sum of these two times is equal to the time of flight.
46. A car moving along a straight highway with speed of 126 km h^{-1} is brought to a stop within a distance of 200 m. What is the retardation of the car (assumed uniform) and how long does it take for the car to stop ?

5 Marks

47. Derive the following equations of motion for an object moving with constant acceleration along a straight line using graphical method and calculus method

(i) velocity time relation ($v = u + at$)

(ii) Position time relation ($s = ut + \frac{1}{2}at^2$)

(iii) velocity-displacement relation ($v^2 = u^2 + 2as$)

where symbols have usual meanings.

48. A projectile is fired horizontally with a velocity u . Show that its trajectory is a parabola. Also obtain expression for

(i) time of flight

(ii) horizontal range

(iii) velocity at any instant.

49. Define centripetal acceleration. Derive an expression for the centripetal acceleration of a particle moving with constant speed v along a circular path of radius r .

NUMERICALS

50. The $V-t$ graphs of two objects make angle 30° and 60° with the time axis. Find the ratio of their accelerations.

51. When the angle between two vectors of equal magnitudes is $2\pi/3$, prove that the magnitude of the resultant is equal to either.

52. If $\vec{A} = 3\hat{i} + 4\hat{j}$ and $\vec{B} = 7\hat{i} + 24\hat{j}$, find a vector having the same magnitude as \vec{B} and parallel to \vec{A} .

53. (a) If \hat{i} and \hat{j} are unit vectors along x & y axis respectively then what is magnitude and direction of $(\hat{i} + \hat{j})$ and $(\hat{i} - \hat{j})$?

(b) Find the components of vector $\vec{a} = 2\hat{i} + 3\hat{j}$ along the directors of vectors $(\hat{i} + \hat{j})$ and $(\hat{i} - \hat{j})$.

54. What is the vector sum of n coplanar forces, each of magnitude F , if each force makes an angle of $\frac{2\pi}{n}$ with the preceding force ?

55. A car is moving along x -axis. As shown in figure it moves from O to P in 18 seconds and return from P to Q in 6 second. What are the average velocity and average speed of the car in going from

(i) O to P

(ii) from O to P and back to Q

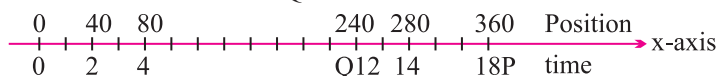

56. On a 60 km straight road, a bus travels the first 30 km with a uniform speed of 30 kmh^{-1} . How fast must the bus travel the next 30 km so as to have average speed of 40 kmh^{-1} for the entire trip ?

57. The displacement x of a particle varies with time as $x = 4t^2 - 15t + 25$. Find the position, velocity and acceleration of the particle at $t = 0$.

58. A driver take 0.20 second to apply the breaks (reaction time). If he is driving car at a speed of 54 kmh^{-1} and the breaks cause a deceleration of 6.0 ms^{-2} . Find the distance travelled by car after he sees the need to put the breaks.

59. From the top of a tower 100 m in height a ball is dropped and at the same time another ball is projected vertically upwards from the ground with a velocity of 25 m/s. Find when and where the two balls will meet ? ($g = 9.8 \text{ m/s}$)

60. A ball thrown vertically upwards with a speed of 19.6 ms^{-1} from the top of a tower returns to the earth in 6s. Find the height of the tower. ($g = 9.8 \text{ m/s}^2$)

61. Two town A and B are connected by a regular bus service with a bus leaving in either direction every T min. A man cycling with a speed of 20 kmh^{-1} in the direction A to B notices that a bus goes past him every 18 min in the direction of his motion, and every 6 min in the opposite direction.

What is the period T of the bus service and with what speed do the busses ply of the road ?

62. A motorboat is racing towards north at 25 kmh^{-1} and the water current in that region is 10 kmh^{-1} in the direction of 60° east of south. Find the resultant velocity of the boat.

63. An aircraft is flying at a height of 3400 m above the ground. If the angle subtended at a ground observation point by the aircraft position 10 second apart is 30° , what is the speed of the aircraft ?

64. A boat is moving with a velocity $(3\hat{i} + 4\hat{j})$ with respect to ground. The water in river is flowing with a velocity $(-3\hat{i} - 4\hat{j})$ with respect to ground. What is the relative velocity of boat with respect to river ?
65. A hiker stands on the edge of a cleft 490 m above the ground and throws a stone horizontally with an initial speed of 15 ms^{-1} . Neglecting air resistance, find the time taken by the stone to reach the ground and the speed with which it hits the ground. ($g = 9.8 \text{ ms}^{-2}$)
66. A bullet fired at an angle of 30° with the horizontal hits the ground 3 km away. By adjusting the angle of projection, can one hope to hit the target 5 km away ? Assume that the muzzle speed to be fixed and neglect air resistance.
67. A stone tied to the end of a string 80 cm long is whirled in a horizontal circle with a constant speed. If the stone makes 14 revolutions in 25 seconds, what is the magnitude and direction of acceleration of the stone ?
68. A cyclist is riding with a speed of 27 kmh^{-1} . As he approaches a circular turn on the road of radius 30 m, he applies brakes and reduces his speed at the constant rate 0.5 ms^{-2} . What is the magnitude and direction of the net acceleration of the cyclist on the circular turn ?
69. If the magnitude of two vectors are 3 and 4 and their scalar product is 6, find angle between them and also find $|\vec{A} \times \vec{B}|$.
70. Find the value of λ so that the vector $\vec{A} = 2\hat{i} + \lambda\hat{j} + \hat{k}$ and $\vec{B} = 4\hat{i} - 2\hat{j} + 2\hat{k}$ are perpendicular to each other.
71. The speed-time graph of a particle along a fixed direction is as shown in Fig. obtain the distance travelled by a particle between (a) $t = 0$ to 10s, (b) $t = 2$ to 6 sec.

What is the average speed of the particle over the intervals in (a) and (b) ?

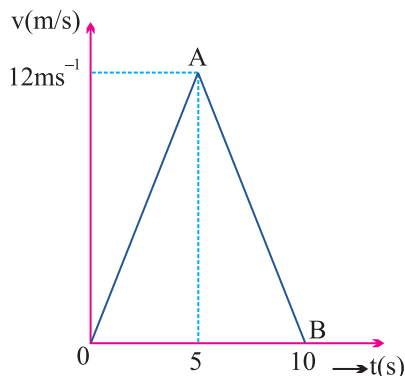

72. The velocity time graph of a particle is given by

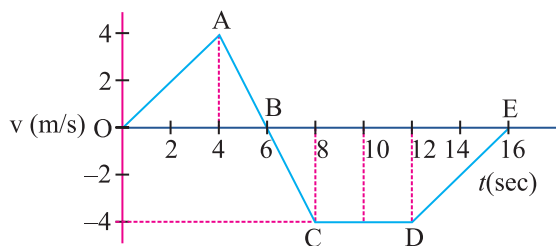

- Calculate distance and displacement of particle from given $v-t$ graph.
 - Specify the time for which particle undergone acceleration, retardation and moves with constant velocity.
 - Calculate acceleration, retardation from given $v-t$ graph.
 - Draw acceleration-time graph of given $v-t$ graph.
73. If \vec{a} , \vec{b} and \vec{c} are represented by three sides of triangle taken in same order.

P. T. $\vec{a} + \vec{b} + \vec{c} = \vec{0}$. [Hint : use Δ law of vector Addition]

74. Prove that for any vector \vec{a} ,

$$\vec{a} = (a \cdot \hat{i})\hat{i} + (a \cdot \hat{j})\hat{j} + (a \cdot \hat{k})\hat{k}$$

75. If R is the horizontal range for θ inclination and h is the maximum height attained by the projectile, show that the maximum range is given by

$$\frac{R^2}{8h} + 2h. \quad \text{[Hint : Put value in relation given & solve]}$$

76. The Resultant of two vectors \vec{P} and \vec{Q} is \vec{R} . If the direction of one of the vector is reversed, then resultant becomes \vec{S} .

Prove that $R^2 + S^2 = 2(P^2 + Q^2)$.

ASSERTION - REASON BASED QUESTIONS

For each questions, two statements are given - one labelled Assertion (A) and the other labelled Reason (R). Select the correct answer to these questions from the codes (a), (b), (c) & (d) are given below.

- Both A and R are true and R is the correct explanation of A.
- Both A and R are true but R is NOT the correct explanation of A.

(c) A is true but R is false.

(d) A is false and R is also true.

1. Assertion (A) : A body can have acceleration even if its velocity is zero at a given instant of time.

Reason (R) : A body is momentarily at rest when it reverses its direction of motion.

2. Assertion (A) : When a body is dropped or thrown horizontally from the same height, it would reach the ground at same time.

Reason (R) : Horizontal velocity has no effect on the vertical direction.

3. Assertion (A) : A stone and a feather dropped from the same height take different time to strike the ground in the presence of air resistance.

Reason (R) : Force of friction due to the air decreases with the weight of body.

4. Assertion (A) : Two bodies of different masses dropped simultaneously from the top of tower hit the ground simultaneously.

Reason (R) : Time taken by a body to fall through certain height is independent of mass of body.

5. Assertion (A) : Minimum number of non-equal vectors in a plane to give zero resultant is three.

Reason (R) : If $\vec{A} + \vec{B} + \vec{C} = \vec{O}$, then they must lie in one plane.

6. Assertion (A) : $\vec{A} \times \vec{B}$ is perpendicular to both $\vec{A} + \vec{B}$ as well as $\vec{A} - \vec{B}$

Reason (R) : $\vec{A} + \vec{B}$ as well as $\vec{A} - \vec{B}$ lie in the plane containing \vec{A} and \vec{B} but $\vec{A} \times \vec{B}$ lies perpendicular to the plane containing \vec{A} and \vec{B} .

7. Assertion (A) : If the speed of a body is constant, the body cannot have a path other than a circular or straight line path.

Reason (R) : It is not possible for a body to have a constant speed in an acceleration motion.

8. Assertion (A) : The position time ($x - t$) graph of a stationary object is a straight line parallel to time axis.

Reason (R) : For a stationary object the position of object does not change with time.

9. Assertion (A) : Angle between $\hat{i} + \hat{j}$ and \hat{i} is 45° .

Reason (R) : $\hat{i} + \hat{j}$ is equally inclined to both \hat{i} and \hat{j} and angle between \hat{i} and \hat{j} is 90° .

10. Assertion (A) : Displacement of a body may be zero, when distance travelled by it is not zero.

Reason (R) : The displacement is the longer distance between initial and final points.

CASE STUDY BASED QUESTIONS

Q1. A ball is projected from the ground level in vertically upward direction with an initial velocity u . The ball goes upto a maximum height H and then starts moving downward. Finally the ball falls back on the ground. It is given that motion of the ball under the action of gravity alone and effect of air resistance, if any, is negligible.

(i) What is the value of maximum height (H) up to which the ball goes?

(a) $H = \frac{u^2}{2g}$ (b) $\frac{u^2}{g}$ (c) $\frac{2u^2}{g}$ (d) $\frac{u}{2g}$

(ii) What time does the ball take to reach the highest point during its motion?

(a) $\frac{2u}{g}$ (b) $\frac{u}{2g}$ (c) $\frac{u}{g}$ (d) $\frac{u^2}{g}$

(iii) What is the acceleration of the body due to gravity

(a) 0 (b) 9.8 m/s^2 (c) 4.9 m/s^2 (d) 19.6 m/s^2

(iv) The motion of ball projected with certain velocity in upward motion is example of what type of motion?

- (a) uniformly acceleration motion
- (b) uniformly retarded motion
- (c) uniform motion
- (d) Non-uniform motion

- (v) What is the shape of position-time graph for entire motion of the ball?
- straight line parallel to time axis.
 - straight line inclined at some angle with time axis.
 - circular
 - parabolic

Q2. Let two objects A and B moving with velocities \vec{V}_A and \vec{V}_B respectively at a particular instant of time, then velocity of object A w.r.t. velocity of object B (i.e. presuming object B to be at rest) is called the relative velocity of A w.r.t. B and is expressed as \vec{V}_{AB} , Thus $\vec{V}_{AB} = \vec{V}_A - \vec{V}_B$

Similarly, relative velocity of object B w.r.t. object A

$$\vec{V}_{BA} = \vec{V}_B - \vec{V}_A$$

Concept of relative velocity is very important in daily life.

- (i) If two objects A & B are in motion along a straight path in same direction, then what is the relative velocity of one object with respect to another? Take direction of A as +ve.
- $\vec{V}_{AB} = \vec{V}_B - \vec{V}_A$
 - $\vec{V}_{AB} = \vec{V}_A - \vec{V}_B$
 - $\vec{V}_{AB} = \vec{V}_A + \vec{V}_B$
 - $\vec{V}_{AB} = -\vec{V}_A - \vec{V}_B$
- (ii) What will be the relative velocity of object A w.r.t. directions? Take direction of A as positive direction.
- $\vec{V}_{AB} = \vec{V}_B - \vec{V}_A$
 - $\vec{V}_{AB} = \vec{V}_A - \vec{V}_B$
 - $\vec{V}_{AB} = \vec{V}_A + \vec{V}_B$
 - $\vec{V}_{AB} = -\vec{V}_A - \vec{V}_B$
- (iii) A thief snatches a bag from a person and then moves along a straight road with a constant velocity of 36 km/h. A police inspector observed the incident of snatching. He starts his bike with in 10s and accelerates it so that he is able to hold the thief after 30s. What is the acceleration of his bike?
- $a = 1.5 \text{ m/s}^2$
 - 2.5 m/s^2
 - 0.5 m/s^2
 - 3.5 m/s^2
- (iv) What is the average velocity of police inspector's bike?
- 25 m/s
 - 20 m/s
 - 30 m/s
 - 15 m/s

- (v) Two trains, each of length 200m, are running on parallel tracks. One overtakes the other in 20 seconds & one crosses the other in 10 seconds. Calculate the velocities of two trains.
- (a) 30 m/s, 10 m/s (b) 20 m/s, 20 m/s
 (c) 30 m/s, 20 m/s (d) 20 m/s, 10 m/s

Q3. When an object follows a circular path at a constant speed, the motion of the object is called 'uniform circular motion'. The word uniform refers to the speed which is uniform throughout the motion. However since the direction of motion is continuously changing, its velocity is changing acceleration. For an object moving with a constant speed v along a circle of radius r , the acceleration $a = \frac{v^2}{r} = \omega^2 r$ and is directed along the radius towards the centre of the circle. Due to this reason, the acceleration is known as centripetal acceleration.

- (i) What is the direction of velocity vector of a particle in uniform circular motion?
- (a) directed along the tangent vector to the circular path.
 (b) directed radially inward towards centre of circle.
 (c) directed radially outward away from centre of circle.
 (d) None of these.
- (ii) What is the direction of centripetal acceleration of a particle in uniform circular motion?
- (a) directed along the tangent vector to the circular path.
 (b) directed radially inward towards centre of circle.
 (c) directed radially outward away from centre of circle.
 (d) None of these.
- (iii) An aircraft executes a horizontal loop of radius 1.5 km with a steady speed of 900 km/h. Compute its centripetal acceleration.
- (a) 30.25 m/s² (b) 37.21 m/s²
 (c) 25.27 m/s² (d) 41.67 m/s²
- (iv) A particular goes round a circle of radius 10 cm at 120 revolutions per minute. Calculate acceleration of the particle.
- (a) $160 \pi^2 \text{ cm/s}^2$ (b) $80 \pi^2 \text{ cm/s}^2$
 (c) $40 \pi^2 \text{ cm/s}^2$ (d) $320 \pi^2 \text{ cm/s}^2$

- (iv) If three vectors \vec{a} , \vec{b} , \vec{c} are represented by three sides of a triangle taken in the same order, then which of the following is correct?
- (a) $\vec{a} + \vec{b} = \vec{c}$ (b) $\vec{a} + \vec{c} = \vec{b}$
 (c) $\vec{a} + \vec{b} + \vec{c} = \vec{0}$ (d) None of these.
- (v) Two vectors, both equal in magnitude have their resultant equal in magnitude of either. Find the angle between these vector.
- (a) 30° (b) 90° (c) 60° (d) 120°

Q5. A projectile is projected from a point O on the ground with an initial velocity u at an elevation angle θ from the horizontal direction as shown in the figure. It just crosses two walls A and B of same height h situated symmetrically at times $t_1 = 2\text{s}$ and $t_2 = 6\text{s}$ respectively. The horizontal distance between the two walls is $d = 120\text{ m}$. (Take $g = 10\text{ m/s}^2$)

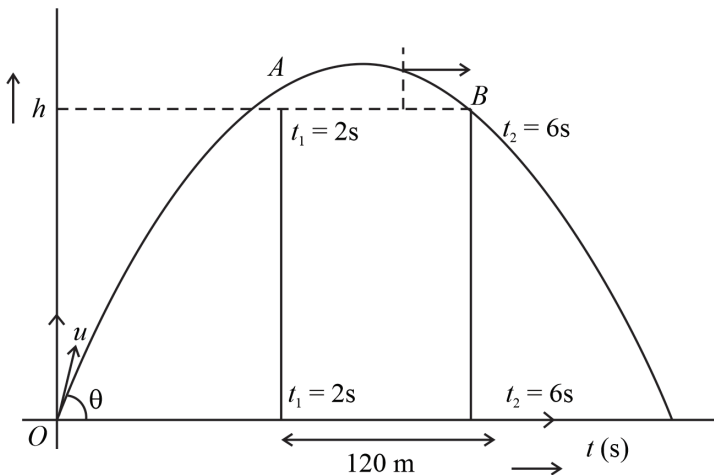

- (i) The projectile motion is an example of -
- (a) one dimensional motion (b) two dimensional motion
 (c) three dimensional motion (d) cannot say, precisely.
- (ii) The total time of flight of the projectile -
- (a) 8s (b) 10s (c) 4s (d) 12s
- (iii) The value of angle of projection θ of the projectile is -
- (a) $\tan^{-1}\left(\frac{3}{4}\right)$ (b) $\tan^{-1}\left(\frac{4}{5}\right)$ (c) $\tan^{-1}\left(\frac{4}{3}\right)$ (d) $\tan^{-1}\left(-\right)$

- (iv) The projectile velocity u of the projectile is -
 (a) 30 m/s (b) 40 m/s (c) 50 m/s (d) $20\sqrt{3}$ m/s
- (v) The height h of either of two walls is -
 (a) 120 m (b) 30 m (c) 15 m (d) 60 m

SOLUTIONS

1. When the body is moving with uniform velocity. [1 Mark Solutions]

2.

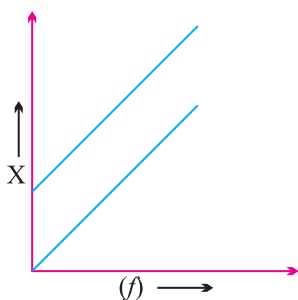

3. Uniform Circular Motion
4. Same height, $\therefore h_1/h_2 = 1$
5. No change
6. Linear velocity
7. will not change.
8. No. (highest point of vertical upward motion under gravity)
9. Here $\frac{1}{2}mv^2 = 1 \text{ KJ} = 1000 \text{ J}$, $\theta = 45^\circ$
 At the highest Point, K. E. = $\frac{1}{2}m(v \cos \theta)^2 = \frac{1}{2} \frac{mv^2}{2} = \frac{1000}{2} = 500 \text{ J}$.
10. The velocity vectors of a stationary object is a zero vectors.
11. They must represent the physical quantities of same nature.
12. When \vec{A} is perpendicular to \vec{B} .
13. Infinite.

14. Because horizontal component of gravity is zero along horizontal direction.
15. 90° .
16. height is maximum at $\theta = 90$
Range is maximum at $\theta = 45$.
17. 90°
18. Radial inward.
19. $\sqrt{a^2 + g^2}$ where g = acceleration due to gravity.
20. Null vector
21. No.
22. $\omega = \frac{2\pi}{12} = \frac{\pi}{6} \text{ rad h}^{-1}$.
23. Gravitation force of sun.
24. $\hat{n} = \frac{\vec{A} \times \vec{B}}{|\vec{A} \times \vec{B}|}$, $\hat{n} = \frac{2\hat{i} - 3\hat{j} - 4\hat{k}}{\sqrt{29}}$.
25. 90°

[2 Marks]

26. If speed of an object increases with time, its acceleration is positive. (Acceleration is in the direction of motion) and if speed of an object decreases with time its acceleration is negative (Acceleration is opposite to the direction of motion).
27. Yes, at the highest point of vertical upward motion under gravity.
28. as $s \propto t^3 \Rightarrow s = kt^3$
velocity, $V = \frac{ds}{dt} = 3kt^2$
acceleration, $a = \frac{dv}{dt} = 6kt$
i.e., $a \propto t$.
 \Rightarrow motion is uniform, accelerated motion, $a - t$ graph is straight-line.
29. A ball thrown up with some initial velocity rebounding from the floor with reduced speed after each hit.

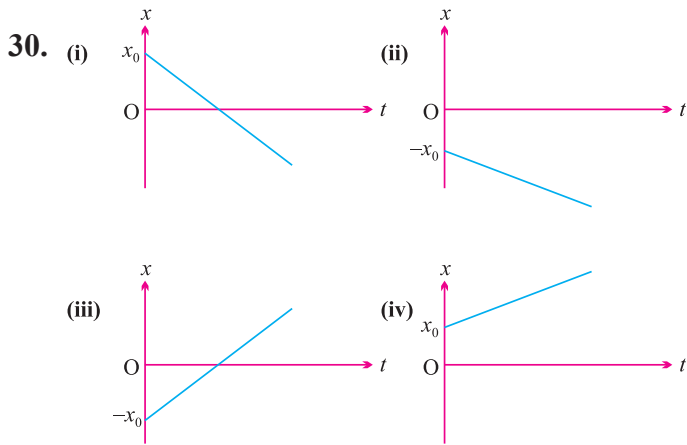

31. Centripetal acceleration, $a_c = \frac{v^2}{r} = \frac{10^2}{1000} = 0.1 \text{ m/s}^2$ along RO.

32. $R = \frac{u^2 \sin 2\theta}{g} \Rightarrow R \propto u^2$

Range becomes four times.

33. Maximum height ; $H = \frac{u^2 \sin^2 \theta}{2g}$

$\Rightarrow H_{\max} = \frac{u^2}{2g} = h(\text{at } \theta = 90^\circ)$

Max. Range $R_{\max} = \frac{u^2}{g} = 2h.$

34. (i) Vertical straight line motion

(ii) Parabolic path.

35. Because bullet follow Parabolic trajectory under constant downward acceleration.

36. No acceleration is towards the centre only in case of uniform circular motion.

37. The object falls with uniform acceleration equal to 'g'

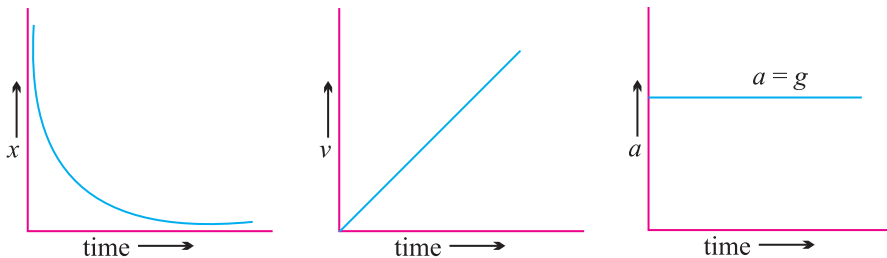

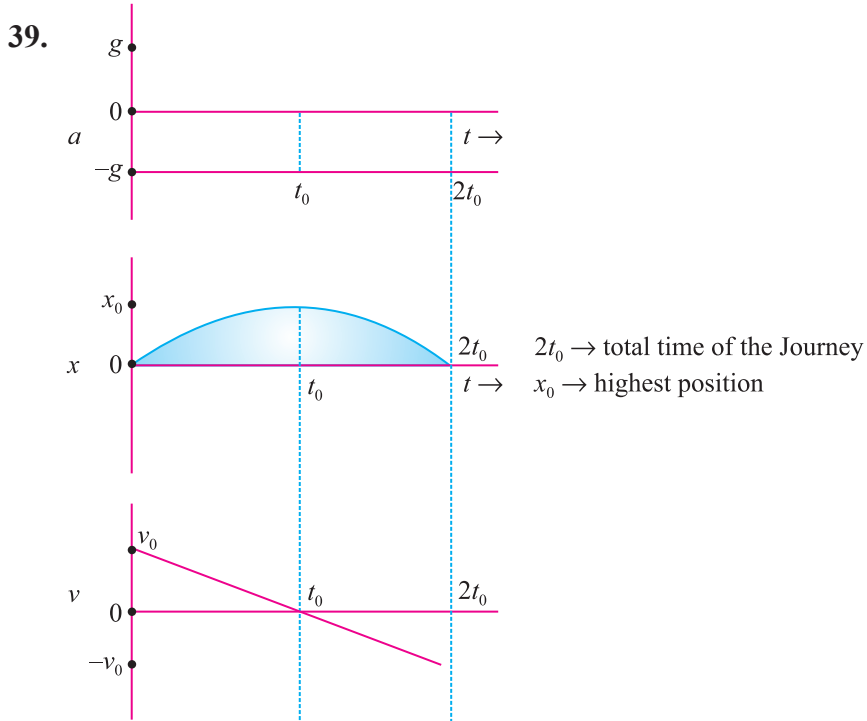
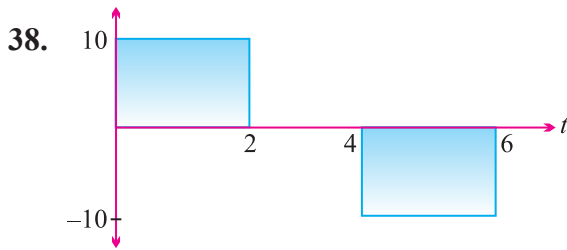

40.

$$a = \frac{dv}{dt} = 3t^2 + 2t + 2$$

$$dv = (3t^2 + 2t + 2)dt$$

$$\int dv = \int (3t^2 + 2t + 2)dt$$

$$v = t^3 + t^2 + 2t + c$$

$c = 2 \text{ m/s}$, $v = 18 \text{ m/s}$ at $t = 2\text{s}$.

41. Use $R = \sqrt{A^2 + B^2 + 2AB\cos\theta}$

$$R = \sqrt{3P^2 + Q^2}, A = P + Q,$$

$$B = P - Q$$

solve, $\theta = 60^\circ$

46. Initial velocity of car,

$$u = 126 \text{ kmh}^{-1} = 126 \times \frac{5}{18} \text{ ms}^{-1} = 35 \text{ ms}^{-1} \quad \dots(\text{i})$$

Since, the car finally comes to rest, $v = 0$

Distance covered, $s = 200 \text{ m}$, $a = ?$, $t = ?$

$$v^2 = u^2 - 2as$$

or
$$a = \frac{v^2 - u^2}{2s} \quad \dots(\text{ii})$$

Substituting the values from eq. (i) in eq. (ii), we get

$$\begin{aligned} a &= \frac{0 - (35)^2}{2 \times 200} = -\frac{35 \times 35}{400} \\ &= -\frac{49}{16} \text{ ms}^{-2} \\ &= -3.06 \text{ ms}^{-2} \end{aligned}$$

Negative sign shows that acceleration is negative which is called retardation, *i.e.*, car is uniformly retarded at $-a = 3.06 \text{ ms}^{-2}$.

To find t , let us use the relation

$$v = u + at$$

$$t = \frac{v - u}{a}$$

Use $a = -3.06 \text{ ms}^{-2}$, $v = 0$, $u = 35 \text{ ms}^{-1}$.

$$\therefore t = \frac{v - u}{a} = \frac{0 - 35}{-3.06} = 11.44 \text{ s}$$

$$\therefore t = 11.44 \text{ sec.}$$

NUMERICALS

50. $\frac{a_1}{a_2} = \frac{\tan 30}{\tan 60} = \frac{1/\sqrt{3}}{\sqrt{3}} = \frac{1}{3} = 1 : 3$

51.
$$\begin{aligned} R &= (P^2 + Q^2 + 2PQ \cos \theta)^{1/2} \\ &= \left(P^2 + P^2 + 2P \cdot P \cos \frac{2\pi}{3} \right)^{1/2} \\ &= \left[2P^2 + 2P^2 \left(\frac{-1}{2} \right) \right]^{1/2} = P \end{aligned}$$

$$52. \quad |\vec{A}| = \sqrt{3^2 + 4^2} = 5$$

$$\text{also} \quad |\vec{B}| = \sqrt{7^2 + 24^2} = 25$$

$$\text{desired vector} = |\vec{B}| \hat{A} = 25 \times \frac{3\hat{i} + 4\hat{j}}{5}$$

$$= 5(3\hat{i} + 4\hat{j}) = 15\hat{i} + 20\hat{j}.$$

54. Resultant force is zero.

55. (i) O to P, Average velocity = 20 ms^{-1}

(ii) O to P and back to Q

$$\text{Average velocity} = 10 \text{ ms}^{-1}$$

$$\text{Average speed} = 20 \text{ ms}^{-1}$$

$$56. \quad V_{\text{avg}} = \frac{S_1 + S_2}{t_1 + t_2} = \frac{S + S}{S \left(\frac{1}{V_1} + \frac{1}{V_2} \right)} = \frac{2V_1V_2}{V_1 + V_2}$$

$$\text{or} \quad 40 = \frac{2 \times 30 \times v_2}{V_1 + V_2} \Rightarrow V_2 = 60 \text{ kmh}^{-1}$$

57. position, $x = 25 \text{ m}$

$$\text{velocity} = \frac{dx}{dt} = 8t - 15,$$

$$t=0, v = 0 - 15 = -15 \text{ m/s}$$

$$\text{acceleration, } a = \frac{dv}{dt} = 8 \text{ ms}^{-2}.$$

58. (distance covered during 0.20 s) + (distance covered until rest)

$$= (15 \times 0.25) + [18.75] = 21.75 \text{ m}$$

59. For the ball chapped from the top

$$x = 4.9t^2 \quad \dots(i)$$

For the ball thrown upwards

$$100 - x = 25t - 4.9t^2 \quad \dots(ii)$$

From eq. (i) & (ii),

$$t = 4\text{s}; x = 78.4 \text{ m}$$

60. using $s = ut + \frac{1}{2}at^2$

$$-h = 19.6 \times 6 + \frac{1}{2} \times (-9.8) \times 6^2$$

$$h = 58.8 \text{ m.}$$

61. $V = 40 \text{ kmh}^{-1}$ and $T = 9 \text{ min.}$

62. $V = 21.8 \text{ kmh}^{-1}$

angle with north, $\theta = 23.4$

63. Speed = 182.2 ms^{-1}

64. $\vec{V}_{BW} = \vec{V}_B - \vec{V}_W$

$$\vec{V}_{BW} = 6\mathbf{i} + 8\mathbf{j}.$$

65. time = 10 seconds

$$V = \sqrt{V_x^2 + V_y^2} = \sqrt{15^2 + 98^2} = 99.1 \text{ m/s}^{-1}.$$

66. Maximum Range = 3.46 km

So it is not possible.

67. $\omega = \frac{88}{25} \text{ rad s}^{-1}$, $\omega = \frac{2\pi}{T} = \frac{2\pi N}{t}$

$$a = 991.2 \text{ cms}^{-2}$$

68. $a_c = \frac{v^2}{r} = 0.7 \text{ ms}^{-2}$

$$a_T = 0.5 \text{ ms}^{-2}$$

$$a = \sqrt{a_c^2 + a_T^2} = 0.86 \text{ ms}^{-2}$$

If θ is the angle between the net acceleration and the velocity of the cyclist,

$$\text{then } \theta = \tan^{-1}\left(\frac{a_c}{a_T}\right) = \tan^{-1}(1.4) = 54^\circ 28'$$

69. $\vec{A} \cdot \vec{B} = AB \cos \theta$,

$$|\vec{A} \times \vec{B}| = AB \sin \theta$$

or $6 = (3 \times 4) \cos \theta$

$$= 3 \times 4 \times \sin 60^\circ$$

or $\theta = 60^\circ$

$$= 3 \times 4 \times \frac{\sqrt{3}}{2} = 6\sqrt{3}$$

$$70. \quad \because \vec{A} \perp \vec{B} \Rightarrow \vec{A} \cdot \vec{B} = 0 \quad \because 8 - 2\lambda + 2 = 0$$

$$\Rightarrow \boxed{\lambda = 5.}$$

71. Refer NCERT.

72. (i) distance = area of ΔOAB + area of trapezium BCDE

$$= 12 + 28 = 40 \text{ m}$$

(ii) displacement = area of ΔOAB – area of trapezium BCDE

$$= 12 - 28 = -16 \text{ m}$$

(iii) time acc. ($0 \leq t \leq 4$) and ($12 \leq t \leq 16$)

retardation ($4 \leq t \leq 8$)

constant velocity ($8 \leq t \leq 12$)

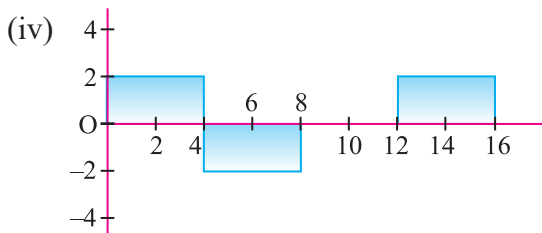

ASSERTION - REASON BASED ANSWERS

1. (a) 2. (a) 3. (c) 4. (a) 5. (b)
 6. (a) 7. (d) 8. (a) 9. (a) 10. (c)

Hints and Explanation :-

5. (b) For giving a zero resultant it should be possible to represent the given vectors along the sides of a closed polygon and minimum number of sides of a polygon is three.
6. (a) Cross product of two vectors is perpendicular to the plane containing both the vectors.
7. (d) If the speed of any body is constant all curved path are possible. In uniform circular motion, a body has a constant speed, but its direction keeps on changing due to which it has non-zero acceleration.

$$9. (a) \quad \cos \theta = \frac{(\hat{i} + \hat{j}) \cdot \hat{i}}{|\hat{i} + \hat{j}| |\hat{i}|} = \frac{1}{\sqrt{2}}, \quad \theta = 45^\circ$$

CASE STUDY BASED ANSWERS

1. i. (a) Consider upward to be positive direction of motion and consider motion upto maximum height.

$$v^2 = u^2 + 2as \quad u = \text{initial velocity}$$

$$0 = u^2 + 2(-g)H \quad a = -g$$

$$H = u^2 / g \quad S = H$$

$$V = 0$$

ii. (b) $v^2 = u + at$

$$0 = u + (-g)t$$

$$\Rightarrow t = \frac{u}{g}$$

iii. (b)

iv. (b)

v. (d)

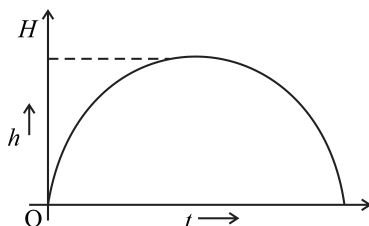

2. i. (b) $\vec{V}_{AB} = \vec{V}_A - \vec{V}_B$

ii. (c) $\vec{V}_{AB} = \vec{V}_A - (-\vec{V}_B) = \vec{V}_A + \vec{V}_B$

- iii. (a) Velocity of thief $V_T = 36 \text{ Km/h} = 10 \text{ m/s}$, $t = 30 \text{ s}$
 distance covered by thief = $S = V_T t = 10 \times 30 = 300 \text{ m}$

initial velocity of inspector's bike = $u_1 = 0$,

actual time taken by inspector = $t = 30' - 10 = 20 \text{ s}$

distance covered by inspector = $S = 300 \text{ m}$

$$300 = 0 \times 20 + \frac{1}{2} \times a \times (20)^2 = 200 a$$

$$a = 1.5 \text{ m/s}^2.$$

iv. (d) Average velocity of inspector = $\frac{300}{20} = 15 \text{ m/s}$

v. (a) Let velocity of A & B be u & v

$$20 = \frac{400}{u - v}$$

$$u - v = 20 \quad \dots (i)$$

Solve (i) & (ii)

$$u = 30 \text{ m/s}, \quad v = 10 \text{ m/s}$$

$$10 = \frac{400}{u + v}$$

$$u + v = 40 \quad \dots (ii)$$

3. i. (a)

ii. (b)

iii. (d) $r = 1.5 \text{ km} = 1500 \text{ m}$ and speed $v = 900 \text{ km/h} = 250 \text{ m/s}$

$$\text{centripetal acceleration } a_c = \frac{v^2}{r} = \frac{250 \times 250}{1500} = 41.67 \text{ m/s}^2$$

iv. (a) $v = 120 \text{ rpm} = \frac{120}{60} = 2 \text{ rps}$

$$a_c = \frac{v^2}{r} = \omega^2 r = 4\pi^2 v^2 r$$

$$a_c = 4\pi^2 (2)^2 (10) = 160\pi^2 \text{ cm/s}^2$$

v. (c)

4. i. (c)

ii. (a) when they are in same direction,

$$\theta = 0^\circ$$

$$R = \sqrt{A^2 + B^2 + 2AB \cos 0^\circ}$$

$$= \sqrt{(A+B)^2} = A+B$$

iii. (a) $|\vec{A} + \vec{B}| = |\vec{A} - \vec{B}|$

It is possible only when \vec{A} and \vec{B} are in mutually perpendicular directions.

iv. (c) $\vec{a} + \vec{b} = -\vec{c}$

$$\vec{a} + \vec{b} + \vec{c} = \vec{0}$$

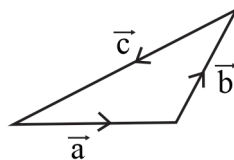

$$v. \quad (d) \quad R = \sqrt{P^2 + Q^2 + 2PQ \cos \theta}$$

$$R = P = Q \quad \text{given}$$

$$P = \sqrt{P^2 + P^2 + 2P^2 \cos \theta}$$

$$\cos \theta = -1/2, \quad \theta = 120^\circ$$

5. i. (b)

ii. (a) If a projectile passes a certain height h at two times t_1 & t_2 then
 $t_1 + t_2 = \text{total time of flight} = T$

$$T = t_1 + t_2 = 2 + 6 = 8 \text{ sec.}$$

iii. (c) $T = \frac{2u \sin \theta}{g} \Rightarrow u \sin \theta = \frac{gT}{2} = \frac{10 \times 8}{2} = 40$

horizontal distance between the wall d

$$d = (u \cos \theta) (t_1 - t_2)$$

$$u \cos \theta = \frac{d}{t_2 - t_1} = \frac{120}{6 - 2} = 30$$

$$\text{Now, } \frac{u \sin \theta}{u \cos \theta} = \frac{40}{30} \Rightarrow \tan \theta = \frac{4}{3}$$

$$\therefore \theta = \tan^{-1} \frac{4}{3}$$

iv. (c) $\tan \theta = \frac{4}{3}, \quad \sin \theta = \frac{4}{\sqrt{4^2 + 3^2}} = \frac{4}{5}$

$$u \sin \theta = 40$$

$$u \times \frac{4}{5} = 40 \Rightarrow u = 50 \text{ m/s}$$

v. (d) $h = (u \sin \theta)t_1 - \frac{1}{2} g t_1^2$

$$h = 40 \times 2 - \frac{1}{2} \times 10(2)^2 = 60 \text{ m}$$

KINEMATICS (M.C.Q.)

1. If the angle between the vectors \vec{A} and \vec{B} is θ , the value of the product $(\vec{B} \times \vec{A}) \cdot \vec{A}$ is equal to
 - (a) $BA^2 \cos \theta$
 - (b) $BA^2 \sin \theta$
 - (c) $BA^2 \sin \theta \cos \theta$
 - (d) Zero

2. For an object thrown at 45° to the horizontal, the maximum height (H) and horizontal range (R) are related as
 - (a) $R = 16 H$
 - (b) $R = 8 H$
 - (c) $R = 4 H$
 - (d) $R = 2 H$

3. The circular motion of a particle with constant speed is
 - (a) Simple harmonic but not periodic
 - (b) Periodic and simple harmonic
 - (c) Neither periodic nor simple harmonic
 - (d) Periodic but not simple harmonic

4. At the upper most of a projectile, its velocity and acceleration are at an angle of
 - (a) 0°
 - (b) 45°
 - (c) 90°
 - (d) 180°

5. If for any two vectors $|\vec{A} + \vec{B}| = |\vec{A} - \vec{B}|$ in a plane, then what is the angle between \vec{A} and \vec{B} ?
 - (a) $\theta = 0$
 - (b) $\theta = 45^\circ$
 - (c) $\theta = 90^\circ$
 - (d) $\theta = 180^\circ$

6. The x and y coordinates of a particle at any time t are given by $x = 7t + 4t^2$ and $y = 5t$, where x and y are in metres and t in seconds. The acceleration of the particle at $t = 5$ s is
 - (a) Zero
 - (b) 8 m/s^2
 - (c) 20 m/s^2
 - (d) 40 m/s^2

7. If K is the kinetic energy of a projectile fired at an angle 45° , then what is the kinetic energy at the highest point.
- (a) $\frac{K}{4}$ (b) $\frac{K}{2}$
(c) K (d) $2K$
8. A particle is moving eastwards with a velocity of 5 m/s. In 10s, the velocity changes to 5 m/s northwards. The average acceleration in this time is
- (a) Zero (b) $\frac{1}{\sqrt{2}}$ m/s² towards north-west
(c) $\frac{1}{2}$ m/s² towards north (d) $\frac{1}{\sqrt{2}}$ m/s² towards north-east
9. A body dropped from top of tower falls through 60 m during the last 2 seconds of its fall. The height of tower is ($g = 10 \text{ m/s}^2$)
- (a) 95 m (b) 80 m
(c) 90 m (d) 60 m
10. The angular velocity of seconds hand of a watch is
- (a) $60 \pi \text{ rad/s}$ (b) $\frac{\pi}{60} \pi \text{ rad/s}$
(c) $40 \pi \text{ rad/s}$ (d) $\frac{\pi}{30} \pi \text{ rad/s}$
11. The angle between the vectors $(\hat{i} + \hat{j})$ and $(\hat{j} + \hat{k})$ is
- (a) 30° (b) 45°
(c) 60° (d) 90°
12. If the scalar and vector products of two vectors \vec{A} and \vec{B} are equal in magnitude, then the angle between the two vectors is
- (a) 45° (b) 90°
(c) 180° (d) 120°
13. An object, moving with a speed of 6.25 m/s, is decelerated at a rate given by
- $$\frac{dv}{dt} = -2.5\sqrt{v}$$

Where V is the instantaneous speed. The time taken by the object, to come to rest would be

- (a) 1 s (b) 2 s
(c) 4 s (d) 8 (s)

14. The velocity-time graph for the vertical component of the velocity of a body thrown upwards from the ground and landing on the roof of a building is given in the figure. The height of the building is

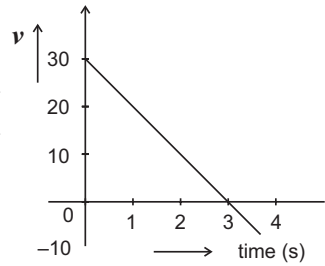

- (a) 50 m (b) 40 m
(c) 20 m (d) 30 m
15. In 1 s, a particle goes from point A to point B moving in a semicircle as shown in figure. The magnitude of the average velocity is

- (a) Zero (b) 1 m/s
(c) 2 m/s (d) 3.14 m/s

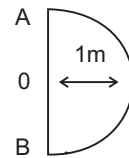

16. A boat which has speed of 5 km/h in still water crosses a river of width 1 km along the shortest possible path in 15 minutes. The velocity of river water in km/hr is

- (a) 1 (b) 3
(c) 4 (d) $\sqrt{41}$

17. A body projected at an angle with the horizontal has a range 300 m. If the time of flight is 6s, then the horizontal component of velocity is

- (a) 30 m/s (b) 50 m/s
(c) 40 m/s (d) 45 m/s

18. Projection of \vec{A} on \vec{B} is

- (a) $\vec{A} \cdot \vec{B}$ (b) $\vec{A} \cdot \hat{B}$
(c) $\vec{A} \times \hat{B}$ (d) $\hat{A} \times \vec{B}$

19. A boy runs along a straight path for the first half distance with a velocity \vec{V}_1 and second half with velocity \vec{V}_2 . The mean velocity \vec{V} is given by

- (a) $\frac{2}{V} = \frac{1}{v_1} + \frac{1}{v_2}$ (b) $V = \frac{V_1 + v_2}{2}$
(c) $V = \sqrt{v_1 \cdot v_2}$ (d) $\vec{V}_1 + \vec{V}_2$

6.

$$x = 7t + 4t^2$$

$$V_x = \frac{dx}{dt} = 7 + 8t$$

$$a_x = \frac{dv_x}{dt} = 8$$

$$y = 5t$$

$$V_y = \frac{dy}{dt} = 5$$

$$a_y = \frac{dv_y}{dt} = 0 \text{ m/s}^2$$

$$a = \sqrt{a_x^2 + a_y^2} = \sqrt{8^2 + 0} \\ = 8 \text{ m/s}^2$$

7.
$$k = \frac{1}{2} mv^2$$

At highest pt., $v = v \cos 45^\circ$

$$\text{K.E} = \frac{1}{2} m \left(\frac{v}{\sqrt{2}} \right)^2 = \frac{v}{\sqrt{2}} \\ = \frac{1}{2} \frac{mv^2}{2} = \frac{K}{2}$$

8.

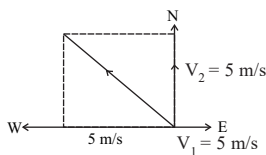

$$\text{acc.} = \frac{\Delta v}{t} \\ = \frac{5\sqrt{2}}{10} = \frac{1}{\sqrt{2}} \text{ m/s}^2$$

$$\vec{V}_1 = 5 \text{ m/s (East)}$$

$$\vec{V}_2 = 5 \text{ m/s (North)}$$

$$\text{Change in velocity} = \vec{V}_t - \vec{V}_i$$

$$= 5\hat{j} - 5\hat{i} \text{ m/s}$$

$$\Delta v = \text{Magnitude of change in velocity}$$

$$= \sqrt{(5)^2 + (5)^2} = 5\sqrt{2} \text{ m/s}$$

9. $U = O$, velocity attained by ball at $t = 2$ second

$$v = u + at = 0 + g(t - 2)$$

distance traveled by ball in last 2s is given by

$$h_1 = vt + \frac{1}{2} at^2$$

$$60 = g(t - 2) \times 2 + \frac{1}{2} g(4) = 20(t - 2) + 20$$

at 4S, Height of tower

$$= \frac{1}{2} g t^2 = \frac{1}{2} \times 10 \times 4^2 = 80 \text{ m}$$

10.
$$w = \frac{2\pi}{T} = \frac{2\pi}{60} = \frac{\pi}{30} \text{ rad/s}$$

11.
$$\cos \theta = \frac{\vec{A} \cdot \vec{B}}{|\vec{A}| |\vec{B}|} \\ = \frac{(\hat{i} + \hat{j}) \cdot (\hat{j} + \hat{k})}{\sqrt{1+1} \sqrt{1+1}} = \frac{0+1+0}{2} \\ \cos \theta = \frac{1}{2} = \cos 60^\circ \\ \theta = 60^\circ$$

$$12. \quad |\vec{A} \cdot \vec{B}| = |\vec{A} \times \vec{B}|$$

$$AB \cos \theta = AB \sin \theta$$

$$1 = \tan \theta$$

$$\tan \theta = 1$$

$$\tan \theta = \tan 45^\circ$$

$$\boxed{\theta = 45^\circ}$$

$$13. \quad \frac{dv}{dt} = -2.5\sqrt{v}$$

$$\int_{6.25}^0 v^{-1/2} dv = \int_0^t 2.5 dt$$

$$\left[\frac{v^{1/2}}{1/2} \right]_{6.25}^0 = 2.5 [t]_0^t$$

$$2[0 - \sqrt{6.25}] = -2.5(t - 0)$$

$$2[-2.5] = -2.5 t$$

$$t = 2s$$

$$14. \quad u = 30 \text{ m/s}$$

$$v = 0 \text{ m/s}$$

$$t = 3s \quad S = h = ?$$

$$v = u + a t$$

$$0 = 30 + a(3)$$

$$a = \frac{-30}{3} = -10 \text{ m/s}^2$$

$$V^2 = u^2 + 2a S$$

$$0 = (30)^2 + 2(-10) h$$

$$-(30)^2 = -20 h$$

$$h = \frac{-30 \times 30}{-20} = 45 \text{ m}$$

From Max. height to roof of building

$$h = \frac{v^2}{2g} = \frac{10^2}{2 \times 10} = 5 \text{ m}$$

$$\text{height of building} = H - h = 45 - 5$$

$$= 40 \text{ m}$$

15. Magnitude of average

$$\text{velocity} = \frac{\text{Magnitude of displacement}}{\text{Time taken}}$$

$$= \frac{2\text{m}}{1\text{s}} = 2\text{ms}^{-1}$$

16.

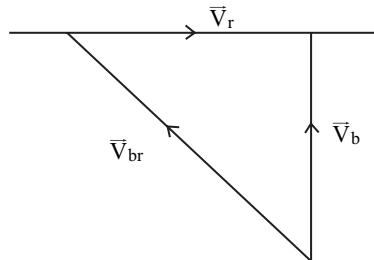

$$\vec{V}_{br} = \vec{V}_b - \vec{V}_r$$

$$V_{br}^2 = V_b^2 + V_r^2$$

$$V_b^2 = 25 - V_r^2 \text{ —————(1)}$$

$$t = \frac{\text{dis tan ce}}{V_b} \Rightarrow$$

$$\frac{1}{4} \text{ hr} = \frac{1}{\sqrt{25 - V_r^2}}$$

$$V_r = 3 \text{ km/h}$$

17. $R = (U \cos \theta)T$

$$U \cos \theta = \frac{R}{T} = \frac{300}{6} = 50 \text{ m/s}$$

18. Projection of \vec{A} on \vec{B}

$$= \frac{\vec{A} \cdot \vec{B}}{|\vec{B}|} = A \cdot \frac{\vec{B}}{|\vec{B}|} = \vec{A} \cdot \hat{B}$$

19. Ar. Velocity

$$V = \frac{S_1 + S_2}{t} = \frac{V_1 t + V_2 t}{t}$$

$$V_1 = \frac{S_1}{t/2}, V_2 = \frac{S_2}{t/2}$$

$$= \frac{V_1 + V_2}{2}$$

20. Since the projectile returns to the plane of projection therefore the net displacement is zero.

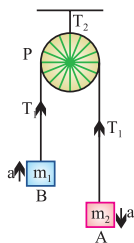

Unit - 3

Newton's Laws Of Motion

And Friction

3.1 Inertia

- (1) Inherent property of all the bodies by virtue of which they cannot change their state of rest or uniform motion along a straight line by their own is called inertia.
- (2) Two bodies of equal mass possess same inertia because it is a factor of mass only.

3.2 Linear Momentum

- (1) Linear momentum of a body is the quantity of motion contained in the body.
- (2) It is measured as the product of the mass of the body and its velocity *i.e.*, Momentum = mass \times velocity.

If a body of mass m is moving with velocity \vec{v} then its linear momentum \vec{p} is given by $\vec{p} = m\vec{v}$.

- (3) It is a vector quantity and its direction is the same as the direction of velocity of the body.
- (4) Units : kg-m/sec [S.I.], g cm/sec [C.G.S.]
- (5) Dimension : [MLT⁻¹]

3.3 Newton's First Law

A body continues to be in its state of rest or of uniform motion along a straight line, unless it is acted upon by some external force to change the state.

- (1) If no net force acts on a body, then the velocity of the body cannot change *i.e.*, the body cannot accelerate.

- (2) Newton's first law defines inertia and is rightly called the law of inertia. Inertia are of three types :
Inertia of rest, Inertia of motion, Inertia of direction.

3.4 Newton's Second Law

- (1) The rate of change of linear momentum of a body is directly proportional to the external force applied on the body and this change takes place always in the direction of the applied force.

- (2) If a body of mass m , moves with velocity \vec{v} then its linear momentum can be given by $\vec{p} = m\vec{v}$ and if force \vec{F} is applied on a body, then

$$\text{or } \vec{F} = \frac{d\vec{p}}{dt} \text{ (K = 1 in C. G. S. and S. I. units)}$$

$$\vec{F} = m\vec{a} \text{ (Force = mass } \times \text{ acceleration)}$$

3.5 Force

- (1) Force is an external effect in the form of a push or pulls which :
(i) Produces or tries to produce motion in a body at rest.
(ii) Stops or tries to stop a moving body.
(iii) Changes or tries to change the direction of motion of the body.

- (2) Dimension : Force = mass \times acceleration

$$[F] = [M][LT^{-2}] = [MLT^{-2}]$$

- (3) Units : Absolute units : (i) Newton (S.I.) (ii) Dyne (C.G.S.)

Gravitational units : (i) Kilogram-force (M.K.S.) (ii) Gram-force (C.G.S.)

- (4) $\vec{F} = m\vec{a}$ formula is valid only if force is changing the state of rest or motion and the mass of the body is constant and finite.

- (5) if m is not constant $\vec{F} = \frac{d}{dt}(m\vec{v}) = m\frac{d\vec{v}}{dt} + \vec{v}\frac{dm}{dt}$.

- (6) No force is required to move a body uniformly along a straight line.

$$\vec{F} = m\vec{a}, \therefore \vec{F} = 0 \text{ (As } a = 0)$$

- (7) When force is written without direction then positive force means repulsive while negative force means attractive.

- (8) Out of so many natural forces nuclear force is strongest while gravitational force weakest.
- (9) **Central force** : If a position dependent force is always directed towards or away from a fixed point it is said to be central otherwise non-central.
- (10) **Conservative or non-conservative force** : If under the action of a force the work done in a round trip is zero or the work is path independent, the force is said to be conservative otherwise non-conservative.

Example : Conservative force : Gravitational force, electric force, elastic force.

Non-conservative force : Frictional force, viscous force.

(11) Common forces in mechanics :

- (i) **Weight** : Weight of an object is the force with which earth attracts it. ($W = mg$)
- (ii) **Reaction or Normal force** : When a body is placed on a rigid surface, the body experience a force which is perpendicular to the surfaces in contact. Then force is called 'Normal force' or 'Reaction'.
- (iii) **Tension** : The force exerted by the end of taut string, rope or chain against pulling (applied) force is called the tension. The direction of tension is so as to pull the body.
- (iv) **Spring force** : Every spring resists any attempt to change its length. This resistive force increases with changes in length. Spring force is given by $F = -Kx$; where x is the change in length and K is the spring constant (unit N/m).

3.6 Equilibrium of Concurrent Force

- (1) If all the force working on a body are acting on the same point, then they are said to be concurrent.
- (2) A body, under the action of concurrent forces, is said to be in equilibrium, when there is no change in the state of rest or of uniform motion along a straight line.
- (3) The condition for the equilibrium of a body is that the vector sum of all the forces acting on the body must be zero.

3.7 Newton's Third Law

To every action, there is always an equal (in magnitude) and opposite (in direction) reaction.

If \vec{F}_{AB} = force exerted on body A by body B (Action) and \vec{F}_{BA} = force exerted on body B by body A (Reaction)

Then according to Newton's third law of motion $\vec{F}_{AB} = -\vec{F}_{BA}$

Example :

- (i) A book lying on a table exerts a force on the table which is equal to the weight of the book. This is the force of action.
- (ii) Swimming is possible due to third law of motion.
- (iii) When a gun is fired, the bullet moves forward (action). The gun recoils backward (reaction).

3.8 Frame of Reference

- (1) A frame in which an observer is situated and makes his observations is known as his 'Frame of reference'.

It is associated with a co-ordinate system.

- (2) Frame of reference are of two types : (i) Inertial frame of reference
(ii) Non-inertial frame of reference.

- (i) Inertial frame of reference :

- (a) A frame of reference which is at rest or which is moving with a uniform velocity along a straight line is called an inertial frame of reference.
- (b) In inertial frame of reference Newton's laws of motion holds good.
- (c) Ideally no inertial frame exist in universe. For practical purpose a frame of reference may be considered as inertial if its acceleration is negligible with respect to the acceleration of the object to be observed.

Example : The lift at rest, lift moving (up or down) with constant velocity.

- (ii) Non inertial frame of reference :

- (a) Accelerated frame of references are called non-inertial frame of reference.
- (b) Newton's laws of motion are not applicable in non-inertial frame of reference.

Example : Car moving in uniform circular motion, lift which is moving upward or downward with some acceleration, plane which is taking off.

3.9 Impulse

- (1) When a large force works on a body for very small time interval, it is called impulsive force.

An impulsive force does not remain constant, but changes first from zero to maximum and then from maximum to zero. In such case we measure the total effect of force.

- (2) Impulse of a force is a measure of total effect of force.

(3)
$$\vec{I} = \int_{t_1}^{t_2} \vec{F} dt.$$

- (4) Impulse is a vector quantity and its direction is same as that of force.

- (5) Dimension : $[MLT^{-1}]$

- (6) Units : Newton second or $Kg\text{-ms}^{-1}$ (S.I.) and Dyne second or $gm\text{ cm s}^{-1}$ (C.G.S.)

- (7) Force-time graph- Impulse is equal to the area under F-t curve.

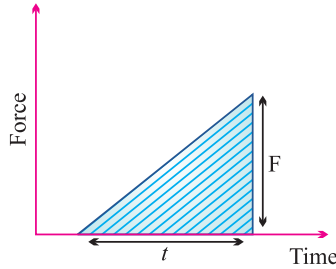

$I = \text{Area between curve and time axis} = \frac{1}{2} Ft$

- (8) If F_{av} is the average magnitude of the force, then

$$I = \int_{t_1}^{t_2} F dt = F_{av} \int_{t_1}^{t_2} dt = F_{av} \Delta t$$

- (9) From Newton's second law, $\vec{F} = \frac{d\vec{p}}{dt}$

or $\int_{t_1}^{t_2} F dt = \int_{p_1}^{p_2} d\vec{p} \Rightarrow \vec{I} = \vec{p}_2 - \vec{p}_1 = \Delta\vec{p}$

i.e., The impulse of a force is equal to the change in momentum. This statement is known as Impulse momentum theorem.

(10) *Examples.* Hitting, kicking, catching, jumping, diving, collision etc.

In all these cases an impulse acts, $I = \int F dt = F_{av} \cdot \Delta t = \Delta p = \text{constant}$
So if time of contact Δt is increased, average force is decreased (or diluted) and vice-versa.

- (i) In catching a ball a player by drawing his hands backwards increases the time of contact and so, lesser force acts on his hands and his hands are saved from getting hurt.
- (ii) China wares are wrapped in straw or paper before packing.

3.10 Law of Conservation of Linear Momentum

If no external force acts on a system (called isolated) of constant mass, the total momentum of the system remains constant with time.

(1) According to this law for a system of particles $\vec{F} = \frac{d\vec{p}}{dt}$

In the absence of external force $\vec{F} = 0$ then $\vec{P} = \text{constant}$.

$i.e., \vec{p} = \vec{p}_1 + \vec{p}_2 + \vec{p}_3 + \dots = \text{constant}$.

- (2) Law of conservation of linear momentum is independent of frame of reference though linear momentum depends on frame of reference.
- (3) Practical applications of the law of conservation of linear momentum
 - (i) When a man jumps out of a boat on the shore, the boat is pushed slightly away from the shore,
 - (ii) A person left on a frictionless surface can get away from it by blowing air out of his mouth or by throwing some object in a direction opposite to the direction in which he wants to move,
 - (iii) Recoiling of a gun-Tor bullet and gun system, the force exerted by trigger will be internal so the momentum of the system remains unaffected.

3.11 Free Body Diagram

In this diagram the object of interest is isolated from its surroundings and the interactions between the object and the surroundings are represented in terms of forces.

3.12 Apparent Weight of a Body in a Lift

When a body of mass m is placed on a weighing machine which is placed in a lift, then actual weight of the body is mg .

This acts on a weighing machine which offers a reaction R given by the reading of weighing machine. The reaction exerted by the surface of contact on the body is the apparent weight of the body.

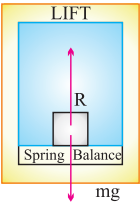
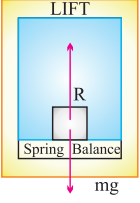
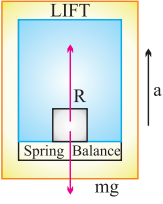
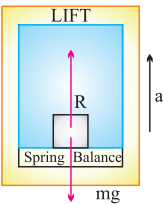
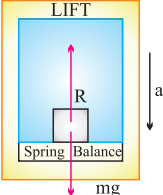
Condition	Figure	velocity	Acceleration	Reaction	Conclusion
Lift is at rest		$v = 0$	$a = 0$	$R - mg = 0$ $\therefore R = mg$	Apparent weight = Actual weight
Lift moving upward or downward with constant velocity		$v = \text{constant}$	$a = 0$	$R - mg = 0$ $\therefore R = mg$	Apparent weight = Actual weight
Lift accelerating upward at the rate of ' a '		$v = \text{variable}$	$a < g$	$R - mg = ma$ $\therefore R = m(g+a)$	Apparent weight > Actual weight
Lift accelerating upward at the rate of ' g '		$V = \text{variable}$	$a = g$	$R - mg = mg$ $R = 2mg$	Apparent weight = 2 Actual weight
Lift accelerating downward at the rate of ' a '		$V = \text{variable}$	$a < g$	$mg - R = ma$ $\therefore R = m(g - a)$	Apparent weight < Actual weight

Lift accelerating downward at the rate of 'g'

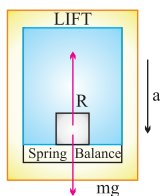

$V = \text{variable } a = g$

$$mg - R = mg$$

$$R = 0$$

Apparent weight = Zero (weightlessness)

Lift accelerating downward at the rate of $a (> g)$

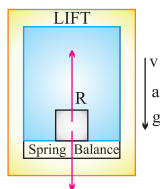

$V = \text{variable } a > g$

$$mg - R = ma$$

$$R = mg - ma$$

$$R = -ve$$

Apparent weight negative means the body will rise from the floor of the

3.13 Acceleration of Block on Horizontal Smooth Surface

(1) When a pull is acting at an angle (θ) to the horizontal (upward)

$$R + F \sin \theta = mg$$

$$\Rightarrow R = mg - F \sin \theta$$

and $F \cos \theta = ma$

$$a = \frac{F \cos \theta}{m}$$

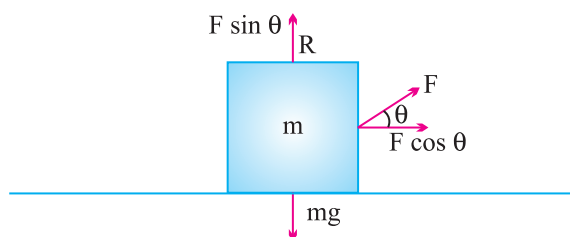

3.14 Acceleration of Block on Smooth Inclined Plane

(1) When inclined plane is at rest.

Normal reaction $R = mg \cos \theta$

Force along a inclined plane $F = mg \sin \theta$

$$ma = mg \sin \theta$$

$$a = g \sin \theta$$

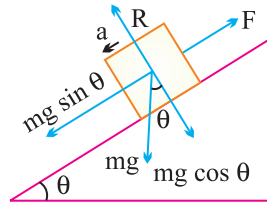

- (2) When an inclined plane is given a horizontal acceleration 'b'. Since the body lies in an accelerating frame, an inertial force acts on it in the opposite direction.

Normal reaction $R = mg \cos \theta + mb \sin \theta$

and $ma = mg \sin \theta - mb \cos \theta$

$$a = g \sin \theta - b \cos \theta$$

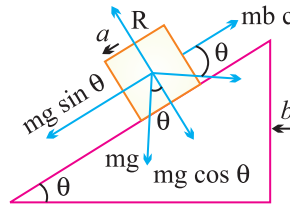

3.15 Motion of Block in Contact

Condition	Free body diagram	Equation	Force and acceleration
		$F - f = m_1 a$ $f = m_2 a$	$a = \frac{F}{m_1 + m_2}$ $f = \frac{m_2 F}{m_1 + m_2}$
		$f = m_1 a$ $F - f = m_2 a$	$a = \frac{F}{m_1 + m_2}$ $f = \frac{m_1 F}{m_1 + m_2}$

$$F - f_1 = m_1 a$$

$$a = \frac{F}{m_1 + m_2 + m_3}$$

$$f_1 - f_2 = m_2 a$$

$$f_1 = \frac{(m_2 + m_3)F}{m_1 + m_2 + m_3}$$

$$f_2 = m_3 a$$

$$f_2 = \frac{m_3 F}{m_1 + m_2 + m_3}$$

$$f_1 = m_1 a$$

$$a = \frac{F}{m_1 + m_2 + m_3}$$

$$f_2 - f_1 = m_2 a$$

$$f_1 = \frac{m_1 F}{m_1 + m_2 + m_3}$$

$$F - f_2 = m_2 a$$

$$f_2 = \frac{(m_1 + m_2)F}{m_1 + m_2 + m_3}$$

3.16 Motion of Blocks Connected by Mass Less String

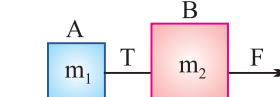
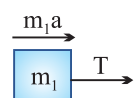
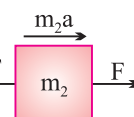
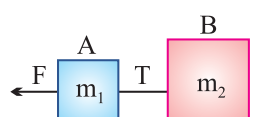
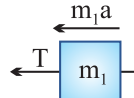
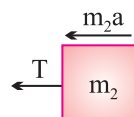
Condition	Free body diagram	Equation	Tension and acceleration
		$T = m_1 a$	$a = \frac{F}{m_1 + m_2}$
		$F - T = m_2 a$	
		$F - T = m_1 a$	$a = \frac{F}{m_1 + m_2}$
		$T = m_2 a$	

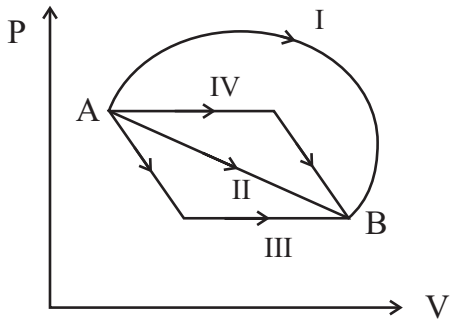

$$T_1 = m_1 a$$

$$a = \frac{F}{m_1 + m_2 + m_3}$$

$$T_2 - T_1 = m_2 a$$

$$T_1 = \frac{m_1 F}{m_1 + m_2 + m_3}$$

$$F - T_2 = m_3 a$$

$$T_2 = \frac{(m_1 + m_2) F}{m_1 + m_2 + m_3}$$

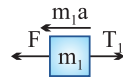

$$F - T_1 = m_1 a$$

$$a = \frac{F}{m_1 + m_2 + m_3}$$

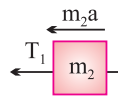
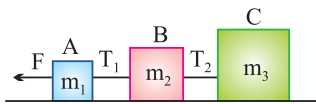

$$T_1 - T_2 = m_2 a$$

$$T_1 = \frac{(m_2 + m_3) F}{m_1 + m_2 + m_3}$$

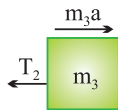

$$T_2 = m_3 a$$

$$T_2 = \frac{m_3 F}{m_1 + m_2 + m_3}$$

3.17 Motion of Connected Block over A Pulley

Condition	Free body diagram	Equation	Tension and acceleration
-----------	-------------------	----------	--------------------------

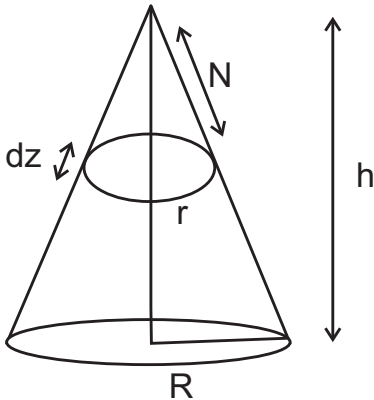

$$m_1 a = T_1 - m_1 g$$

$$T_1 = \frac{2m_1 m_2}{m_1 + m_2} g$$

$$m_2 a = m_2 g - T_1$$

$$T_2 = \frac{4m_1 m_2}{m_1 + m_2} g$$

$$T_2 = 2T_1$$

$$a = \left[\frac{m_2 - m_1}{m_1 + m_2} \right] g$$

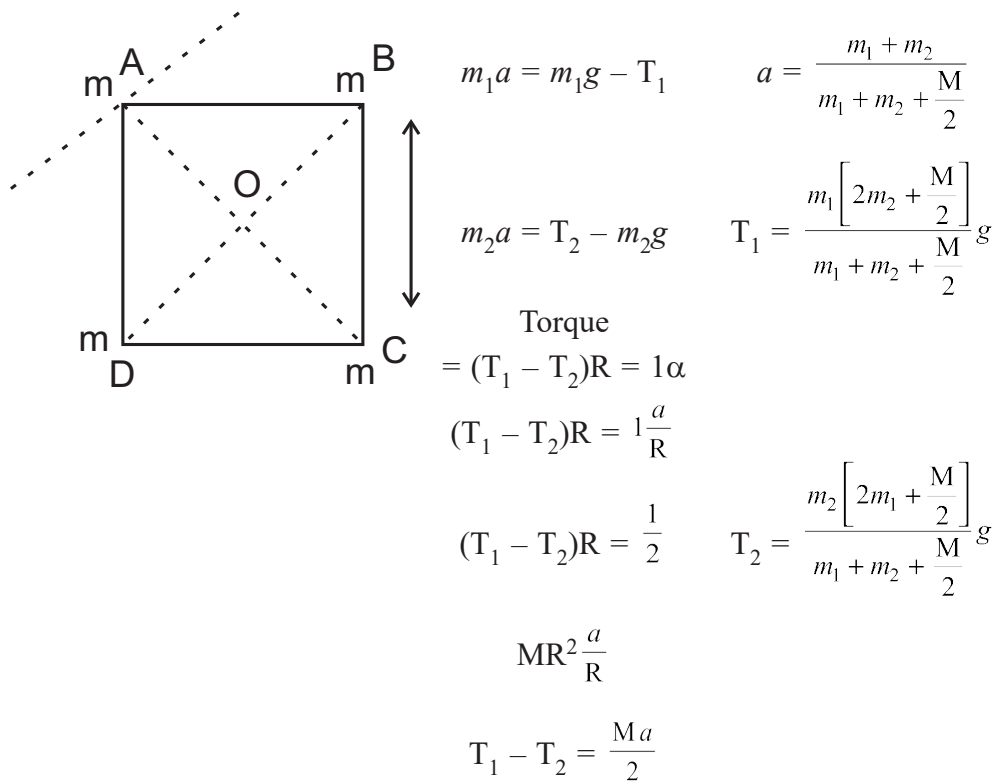
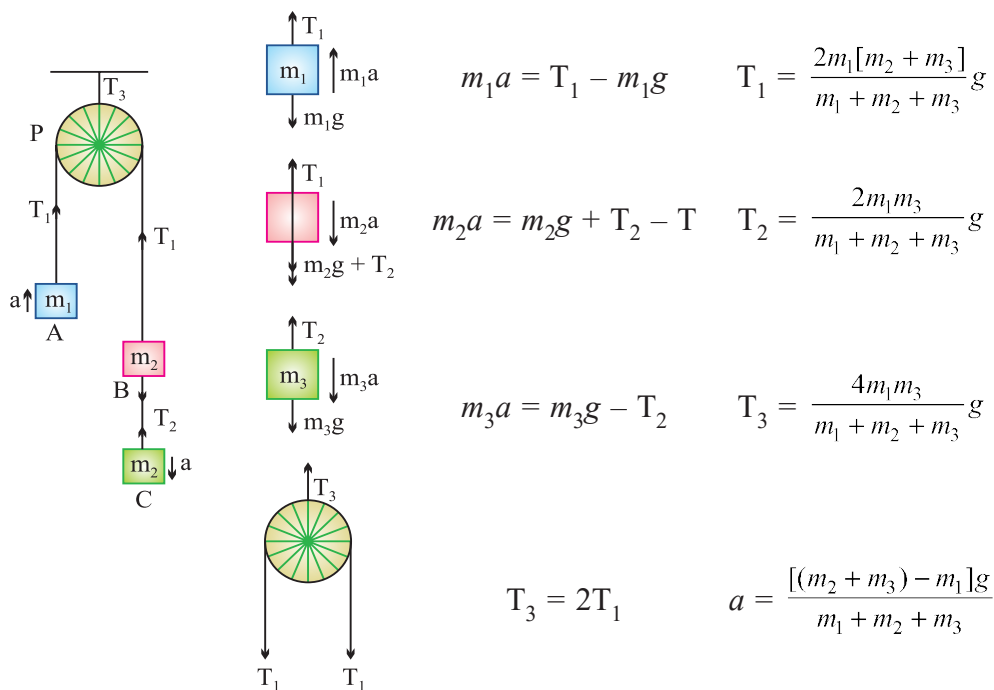

3.18 Friction (Introduction)

If we slide or try to slide a body over a surface the motion is resisted by a bonding between the body and the surface. This resistance is represented by a single force and is called friction.

The force of friction is parallel to the surface and opposite to the direction of intended motion.

3.19 Types of Friction

(1) **Static friction** : The opposing force that comes into play when objects are at rest.

(i) In this case static friction $F = P$.

(ii) Static friction is a self-adjusting force because it changes itself in accordance with the applied force.

(2) **Limiting friction** : The maximum value of static friction upto which body does not move is called limiting friction.

(i) The magnitude of limiting friction between any two bodies in contact is directly proportional to the normal reaction between them.

$$F_1 \propto R \text{ or } F_1 = \mu_s R$$

(ii) Direction of the force of limiting friction is always opposite to the direction in which one body is at the verge of moving.

(iii) Coefficient of static friction :

(a) μ_s is called coefficient of static friction.

(b) Dimension : $[M^0L^0T^0]$

(c) Unit : It has no unit.

(d) Value of μ_s lies in between 0 and 1

(e) Value of μ depends on material and nature of surfaces in contact.

(f) Value of μ does not depend upon apparent area of contact.

(3) **Kinetic or dynamic friction** : If the applied force sets the body in motion, the friction opposing the motion is called kinetic friction.

(i) Kinetic friction depends upon the normal reaction friction.

$F_k \propto R$ or $F_k = \mu_k R$ where μ_k is called the coefficient of kinetic friction.

(ii) Kinetic friction is always lesser than limiting friction $F_k < F_1$,
... $\mu_k < \mu_s$

Thus we require more force to start a motion than to maintain it against friction. This is because when motion has actually started, irregularities of one surface have little time to get locked again into the irregularities of the other surface.

(iv) Types of kinetic friction : (a) Sliding friction (b) Rolling friction

- Rolling friction is directly proportional to the normal reaction (R) and inversely proportional to the radius (r) of the rolling cylinder or wheel.

$$F_{\text{Rolling}} = \mu_r \frac{R}{r}$$

μ is called coefficient of rolling friction. It would have the dimensions of length and would be measured in *metre*.

- Rolling friction is often quite small as compared to the sliding friction.
- In rolling the surfaces at contact do not rub each other.
- The velocity of point of contact with respect to the surface remains zero all the times.

3.20 Graph Between Applied Force and Force of Friction

- (1) Part OA = static friction (F_s).
- (2) At point A = limiting friction (F_1).
- (3) Beyond A, the force of friction is seen to decrease slightly.

The portion BC = kinetic friction (F_k).

- (4) As the portion BC of the curve is parallel to x axis therefore kinetic friction does not change with the applied force.

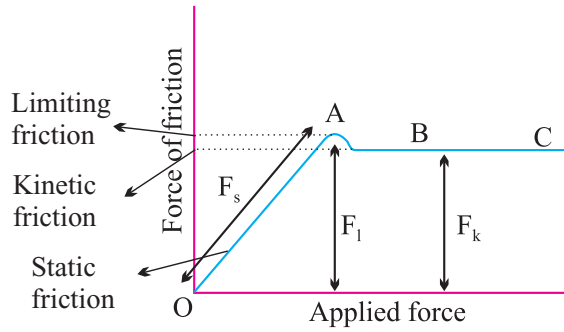

3.21 Angle of Friction

Angle of friction may be defined as the angle which the resultant limiting friction and normal reaction makes with the normal reaction.

By definition angle θ is called the angle of friction $\tan \theta = \frac{F}{R}$

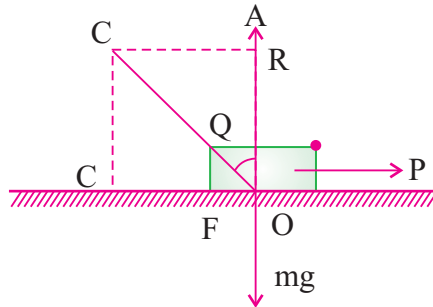

$$\therefore \tan \theta = \mu \quad \left[\text{As we know } \frac{F}{R} = \mu \right]$$

or $\theta = \tan^{-1} (\mu)$

3.22 Angle of Repose

Angle of repose is defined as the angle of the inclined plane with horizontal such that a body placed on it is just begins to slide.

If α is called the angle of repose.

$\alpha = \theta$ i.e., angle of repose = angle of friction.

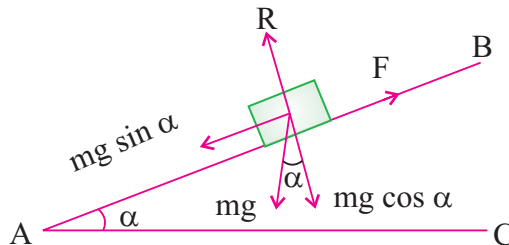

UNIT-III (Laws of Motion)

1 Mark Questions

1. A passenger sitting in a car at rest, pushes the car from within. The car doesn't move, why ?
2. Give the magnitude and directions of the net force acting on a rain drop falling with a constant speed.
3. Why the passengers in a moving car are thrown outwards when it suddenly takes a turn ?
4. You accelerate your car forward. What is the direction of the frictional force on a package resting on the floor of the car ?
5. What is the purpose of using shockers in a car ?
6. Why are tyres made of rubber not of steel ?
7. Wheels are made circular. Why ?
8. If a ball is thrown up in a moving train, it comes back to the thrower's hands. Why ?
9. Calculate the force acting on a body which changes the momentum of the body at the rate of $1 \text{ kg}\cdot\text{m/s}^2$.
10. On a rainy day skidding takes place along a curved path. Why ?
11. Why does a gun recoils when a bullet is being fired ?
12. Why is it difficult to catch a cricket ball than a tennis ball even when both are moving with the same velocity ?
13. The distance travelled by a moving body is directly proportional to time. Is any external force acting on it ?
14. Calculate the impulse necessary to stop a 1500 kg car moving at a speed of 25 ms^{-1} .
15. Lubricants are used between the two parts of a machine. Why ?
16. What provides the centripetal force to a car taking a turn on a level road ?
17. A body is acted upon by a number of external forces. Can it remain at rest ?
18. Bodies of larger mass need greater initial effort to put them in motion. Why ?
19. An athlete runs a certain distance before taking a long jump. Why ?
20. Action and reaction forces do not balance each other. Why. ?
21. The wheels of vehicles are provided with mudguards. Why ?

22. China wares are wrapped in straw paper before packing. Why ?
23. Why is it difficult to walk on a sand ?
24. The outer edge of a curved road is generally raised over the inner edge. Why ?
25. Explain why the water doesn't fall even at the top of the circle when the bucket full of water is upside down rotating in a vertical circle ?
26. Why does a speedy motor cyclist bends towards the centre of a circular path while taking a turn on it ?
27. An impulse is applied to a moving object with a force at an angle of 20° w.r.t. velocity vector, what is the angle between the impulse vector and change in momentum vector ?

2 Marks Questions

28. A man getting out of a moving bus runs in the same direction for a certain distance. Comment.
29. If the net force acting upon the particle is zero, show that its linear momentum remains constant.
30. A force of 36 dynes is inclined to the horizontal at an angle of 60° . Find the acceleration in a mass of 18 g that moves in a horizontal direction.
31. The motion of a particle of mass m is described by $h = ut + 1/2 gt^2$. Find the force acting on particle. ($F = mg$)
32. A particle of mass 0.3 kg is subjected to a force of $F = -kx$ with $k = 15 \text{ Nm}^{-1}$. What will be its initial acceleration if it is released from a point 20 cm away from the origin ?
33. A 50 g bullet is fired from a 10 kg gun with a speed of 500 ms^{-1} . What is the speed of the recoil of the gun.
34. Smooth block is released at rest on a 45° incline and then slides a distance d . If the time taken of slide on rough incline is n times as large as that to slide than on a smooth incline. Show that coefficient of friction.

$$\mu = \left(1 - \frac{1}{n^2}\right).$$
35. A spring balance is attached to the ceiling of a lift. When the lift is at rest spring balance reads 49 N of a body hang on it. If the lift moves :
 - (i) Downward
 - (ii) upward, with an acceleration of 5 ms^{-2}

(iii) with a constant velocity.

What will be the reading of the balance in each case ?

36. It is easier to pull a roller than to push it. Why ? (using vector diagram)
37. A horse cannot pull a cart and run in empty space. Why ? (using diagram)
38. A bob of mass 0.1 kg hung from the ceiling of room by a string 2 m long is oscillating. At its mean position the speed of a bob is 1 ms^{-1} . What is the trajectory of the oscillating bob if the string is cut when the bob is
- At the mean position
 - At its extreme position.
39. Define force of friction. How does ball bearing reduce friction ?
40. Define angle of friction and angle of repose.
41. A block placed on a rough horizontal surface is pulled by a horizontal force F . Let f be the force applied by the rough surface on the block. Plot a graph of f versus F .
42. A mass of 2 kg is suspended with thread AB. Thread CD of the same type is attached. To the other end of 2 kg mass.
- Lower end of the lower thread is pulled gradually, hander and hander is the downward direction so as to apply force on AB. Which of the thread will break & why ?

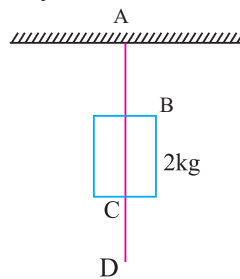

- If the lower thread is pulled with a jerk, what happens ?
43. A block of mass M is held against a rough vertical wall by pressing it with a finger. If the coefficient of friction between the block and the wall is μ and the acceleration due to gravity is g , calculate the minimum force required to be applied by the finger to held the block against the wall ?

NUMERICALS (3 Marks Questions)

44. A block of mass 500 g is at rest on a horizontal table. What steady force is required to give the block a velocity of 200 cms^{-1} in 4 s ?

45. A force of 98 N is just required to move a mass of 45 kg on a rough horizontal surface. Find the coefficient of friction and angle of friction ?
46. Calculate the force required to move a train of 2000 quintal up on an incline plane of 1 in 50 with an acceleration of 2 ms^{-2} . The force of friction per quintal is 0.5 N.
47. A force of 100 N gives a mass m_1 , an acceleration of 10 ms^{-2} and of 20 ms^{-2} to a mass m_2 . What acceleration must be given to it if both the masses are tied together ?
48. The pulley arrangement of fig. are identical. The mass of the rope is negligible. In (a) mass m is lifted up by attaching a mass ($2m$) to the other end of the rope. In (b), m is lifted up by pulling the other end of the rope with a constant downward force $F = 2mg$. In which case, the acceleration of m is more ?

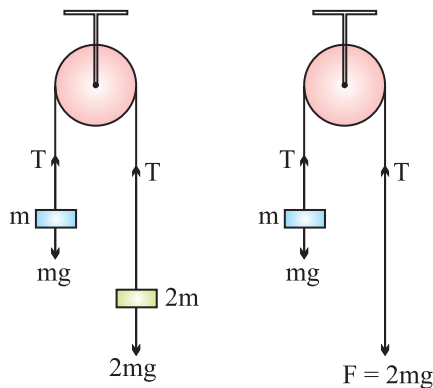

49. Fig. shows the position-time graph of a particle of mass 4 kg. What is the

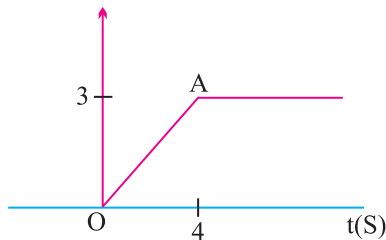

- (a) Force on the particle for $t < 0$, $t > 4s$, $0 < t < 4s$?
- (b) Impulse at $t = 0$ and $t = 4s$?
- (Consider one dimensional motion only)
50. What is the acceleration of the block and trolley system as the fig., if the coefficient of kinetic friction between the trolley and the surface is 0.04 ? Also Calculate friction in the string.

Take $g = 10 \text{ m/s}^2$, mass of the string is negligible.

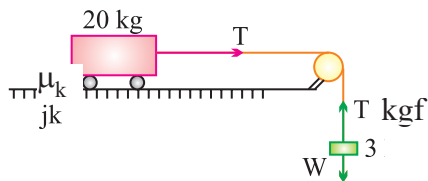

51. Three blocks of masses $m_1 = 10 \text{ kg}$, $m_2 = 20 \text{ kg}$ are connected by strings on smooth horizontal surface and pulled by a force of 60 N . Find the acceleration of the system and frictions in the string.

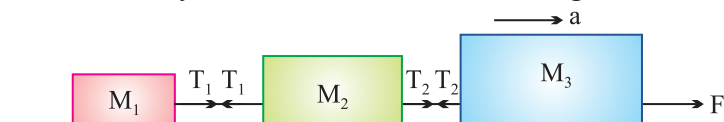

52. The rear side of a truck is open and a box of 40 kg mass is placed 5 m away from the open end. The coefficient of friction between the box and the surface below it is 0.15 on a straight road, the truck starts from rest and accelerates with 2 m/s^2 . At what distance from the starting point does the box fall off the truck ? (ignore the size of the box)
53. A block slides down an incline of 30° with the horizontal. Starting from rest, it covers 8 m in the first 2 seconds . Find the coefficient of static friction.
54. A helicopter of mass 2000 kg rises with a vertical acceleration of 15 m/s^2 . The total mass of the crew and passengers is 500 kg . Give the magnitude and direction of the :
- Force on the floor of the helicopter by the crew and passenger.
 - Action of the rotor of the helicopter on the surrounding air
 - Force on the helicopter due to the surrounding air ($g = 10 \text{ m/s}^2$)
55. A rectangular box lies on a rough inclined surface. The coefficient of friction between the surface and the box is (μ) . Let the mass of the box be m .
- At what angle of inclination θ of the plane to the horizontal will the box just start to slide down the plane ?
 - What is the force acting on the box down the plane, if the angle of inclination of the plane is increased to $\alpha > \theta$.
 - What is the force needed to be applied upwards along the plane to make the box either remain stationary or just move up with uniform speed ?

- (d) What is the force needed to be applied upwards along the plane to make the box move up the plane with acceleration a ?
56. Two masses of 5 kg and 3 kg are suspended with help of mass less inextensible string as shown. Calculate T_1 and T_2 when system is going upwards with acceleration m/s^2 . (Use $g = 9.8 m/s^2$)

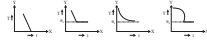

57. There are few forces acting at a Point P produced by strings as shown, which is at rest, Find the forces F_1 & F_2

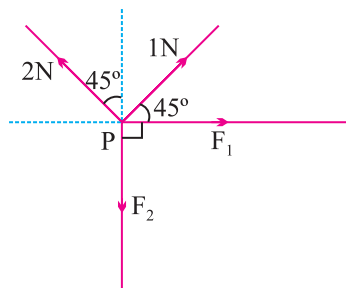

58. A hunter has a machine gun that can fire 50g bullets with a velocity of $150 ms^{-1}$. A 60 kg tiger springs at him with a velocity of $10 ms^{-1}$. How many bullets must the hunter fire into the target so as to stop him in his track ?
59. Two blocks of mass 2 kg and 5 kg are connected by an ideal string passing over a pulley. The block of mass 2 kg is free to slide on a surface inclined at an angle of 30° with the horizontal whereas 5 kg block hangs freely. Find the acceleration of the system and the tension in the string.
60. Show that Newton's second law of motion is the real law of motion.

5 Marks Questions

61. Define the principle of conservation of linear momentum. Deduce the law of conservation of linear momentum from Newton's third law of motion.
62. Why circular roads are banked ? Derive an expression for angle of banking for safe circular turn. Consider that coefficient of friction between the tyre and road is μ .

63. Obtain an expression for minimum velocity of projection of a body at the lowest point for looping a vertical loop.
64. Show that the area under the force-time graph gives the magnitude of the impulse of the given force for the following case when (i) force is constant (ii) variable force.
65. Derive an expression for acceleration of a body down a rough inclined plane ? (Sliding only)
66. With the help of suitable example, explain the terms static friction, limiting friction and kinetic friction. Show that static friction is a self adjusting force. Also plot the graph showing the variation between applied force F and force of friction f .

ASSERTION - REASON BASED QUESTIONS

For each questions, two students are given - one labelled Assertion (A) and the other labelled Reason (R). Select the correct answer to these questions from the codes (a), (b), (c) & (d) are given below.

- (a) Both A and R are true but R is the correct explanation of A.
 - (b) Both A and R are true but R is NOT the correct explanation of A.
 - (c) A is true but R is false.
 - (d) A is false but R is also false.
1. Assertion (A) : A rocket moves forward by pushing the surrounding air backwards.
Reason (R) : It drives the necessary thrust to move forward according to Newton's third law of motion.
 2. Assertion (A) : A man in a closed cabin, which is falling freely, does not experience gravity.
Reason (R) : Inertial and gravitational masses have equivalence.
 3. Assertion (A) : Centripetal force is always required for motion in curved path.
Reason (R) : On a banked curved track, vertical component of normal reaction provides the necessary centripetal force.
 4. Assertion (A) : It is difficult to move a cycle along the road with brakes on.
Reason (R) : Sliding friction is greater than rolling friction.

5. Assertion (A) : Friction forces are conservative forces.
Reason (R) : Potential energy can be associated with frictional force.
6. Assertion (A) : Use of ball bearings between two moving parts of a machine is a common practice.
Reason (R) : Ball bearings reduce vibrations and provide good stability.
7. Assertion (A) : The driver in a vehicle moving with a constant speed on a straight road is a non-inertial frame of reference.
Reason (R) : A reference frame in which Newton's laws of motion are applicable is non-inertial.
8. Assertion (A) : A table cloth can be pulled from a table without dislodging the dishes.
Reason (R) : To every action there is an equal and opposite reaction.
9. Assertion (A) : The apparent weight of a body in an elevator moving with some downward acceleration is less than the actual weight of a body.
Reason (R) : The part of the weight is spent in producing downward acceleration, when body is in elevator.
10. Assertion (A) : Angle of repose is equal to angle of friction.
Reason (R) : When a body is at the point of motion, the force of friction at this stage is called limiting friction.

CASE STUDY BASED QUESTIONS

- Q1.** A person weighing 60 kg is standing on a platform scale balance kept on the floor of an elevator cab. The elevator cab is capable of motion in up or down direction with either a uniform velocity or a constant acceleration. The value of velocity as well as acceleration may be adjusted at any suitable value. Newton's second law of motion can be applied for the motion of elevator cab.
- (i) The observed weight a person in an elevator is -
- (a) remains same and is equal to actual weight
 - (b) always increases
 - (c) always decreases
 - (d) Increases or decreases depending upon motion of elevator

- (ii) Find the observed weight of the person as recorded by the balance when, the elevator cab is moving upward with a constant velocity of 2 m/s.
- (a) 0 N (b) 30 gN (c) 60 gN (d) 90 gN
- (iii) The elevator cab is in an accelerated motion in vertical downward direction, with an acceleration of $g/4$
- (a) 0 N (b) 45 gN (c) 90 gN (d) 60 gN
- (iv) The elevator cab starts falling downward freely due to some mechanical failure in its control system.
- (a) 0 N (b) 75 gN (c) 120 gN (d) 90 gN
- (v) The elevator cab is accelerating uniformly in upward directions with uniform acceleration of $g/2$.
- (a) 0 N (b) 120 gN (c) 30 gN (d) 90 gN

Q2. When two bodies are in contact, each experiences a contact force by the other. The component of the contact force parallel to the surfaces in contact, which opposes impending or actual relative motion between the two bodies in contact is opposed by static friction. Kinetic friction opposes actual relative motion between two bodies in contact.

There is a yet another type of friction which opposes rolling motion of one body over the surface of another body. It is called rolling friction.

We often regard friction as something undesirable. However in many practical situations friction is critically needed.

- (i) What is the direction of friction?
- (a) Friction always acts tangential to the surface in contact.
 (b) Friction acts normal to the surface in contact.
 (c) Direction depends upon weight of body which moves over surface of another body.
 (d) None of these.
- (ii) Which one of the statement is not correct about friction?
- (a) friction is an self adjusting force.
 (b) force of friction is independent of area of contact as long as normal reaction remains same.
 (c) sliding friction is greater than static friction.
 (d) limiting friction is the maximum static friction.
- (iii) An automobile is moving on a horizontal road with a speed V . If the

coefficient of friction between the tyres and the road is μ . What is the shortest distance in which the automobile can be stopped?

- (a) $\frac{v^2}{\mu g}$ (b) $\frac{2v^2}{\mu g}$ (c) $\frac{v^2}{4\mu g}$ (d) $\frac{v^2}{2\mu g}$

(iv) What will be the maximum acceleration of the train in which a box lying on the floor will remain stationary? Given that the coefficient of friction between the box and trains floor is 0.15. ($g= 10\text{m/s}^2$).

- (a) 2 m/s^2 (b) 2.5 m/s^2 (c) 1 m/s^2 (d) 1.5 m/s^2

(v) In figure, the masses of blocks A & B are 10 kg and 5 kg. Calculate the minimum mass of C which may stop A from slipping. Coefficient of friction between block A and table is 0.2.

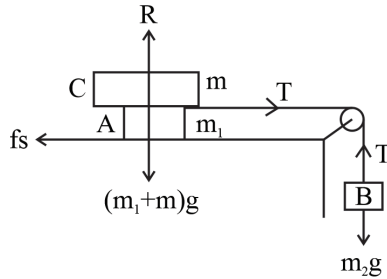

- (a) 5 kg (b) 15 kg (c) 25 kg (d) 35 kg

Q3. In our daily life experiences, we sometime encounter situations where a force acts on a body for a very short interval of time. For example when a batsman hits a ball by the bat with some force, then time of contact between the bat and the ball is very short. In this situation, a finite change in momentum of the ball is produced by the force, which is provided by the bat with in the small duration of time. The product of force and the time duration for which the force acts on a body is called impulse and is equal to change in momentum of the body.

(i) Which of the following physical quantity has same dimensional formulae as that of impulse?

- (a) Pressure (b) Momentum
(c) Tension (d) Surface energy

(ii) A batsman hits back a ball straight in the direction of bowler without changing its initial speed of 12 m/s. If the mass of the ball is 0.15 kg, determine the impulse imparted to the ball. (Assume linear motion of the ball)

- (a) 1.8 Ns (b) 2.2 Ns (c) 3.6 Ns (d) 4.8 Ns

(iii) Figure shows the position-time graph of a particle of mass 4 kg. What is the impulse at $t = 4$ s.

- (a) -3 kg m/s
- (b) 3 kg m/s
- (c) 2 kg m/s
- (d) -2 kg m/s

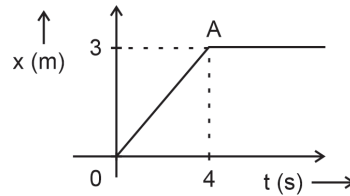

(iv) Figure shows the position time graph of a body of mass 0.04 kg. What is magnitude of impulse at $t = 2$ s.

- (a) $16 \times 10^{-4} \text{ kg ms}^{-1}$
- (b) $2 \times 10^{-4} \text{ kg ms}^{-1}$
- (c) $4 \times 10^{-4} \text{ kg ms}^{-1}$
- (d) $8 \times 10^{-4} \text{ kg ms}^{-1}$

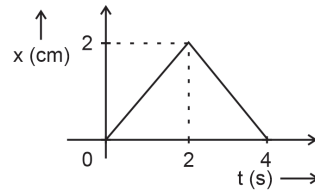

(v) A 3 kg ball strikes a heavy rigid wall with a speed of 10 m/s at an angle of 60° with normal to wall. It gets reflected with the same speed and is in contact with wall for 0.2s. What is impulse exerted by wall on ball.

- (a) 60 Ns
- (b) 30 Ns
- (c) 15 Ns
- (d) 20 Ns

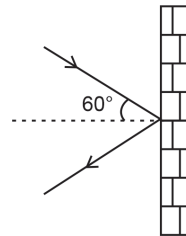

Q4. The maximum permissible speed for a vehicle to negotiate a turn on a level circular road (without getting slip), depends upon the value of coefficient of friction μ between the tyres and road. But in practice, this limiting value of speed for sharp turn is quite low, especially in hilly areas where the turns are too sharp. In order to move the vehicle at a reasonable speed without getting skid/slip to go around the sharp turns of the inner one. It is called banking of road.

Banking of roads provide the necessary centripetal force which is needed to make sharp turn with reasonable speed and without getting skid.

- (i) Force responsible for the circular motion of the body is
 - (a) Centripetal force
 - (b) Centrifugal force
 - (c) Gravitational force
 - (d) None of these

7. Rolling friction is less than sliding friction.
8. Both during its upward and downward motion, the ball continues to move inertia of motion with the same horizontal velocity as the train. In this period, the ball covers the same horizontal distance as the train and so it comes back to the thrower's hand.
9. As $F = \text{rate change of momentum}$

$$F = 1\text{kg}\cdot\text{m}/\text{s}^2 = 1\text{N}$$

10. As the friction between the tyres and road reduces on a rainy day.
11. To conserve momentum.
12. Being heavier, cricket ball has higher rate of change of momentum during motion so more force sumed.
13. As $s \propto t$, so acceleration $a = 0$, therefore, no external force is acting on the body.
14. Use formula $I = \text{change in momentum} = m(v - u)$
(Ans. – 37500 Ns)
15. To reduce friction and so to reduce wear & tear.
16. Force of friction between the tyre and road provides centripetal force.
17. Yes, if the external forces acting on the body can be represented in magnitude and direction by the sides of a closed polygon taken in the same order.
18. As $F = ma$ so for given a , more force will be required to put a large mass in motion.
19. So that inertia of motion may help him in his muscular efforts to take a longer jump.
20. As they acts on different bodies.
21. When the wheel rotates at a high speed, the mud sticking to the wheel flies off tangentially, this is due to inertia of direction. If order that the flying mud does not spiral the clothes of passer by the wheels are provided with mudguards .
22. The straw paper between the China ware increases the Time of experiencing the jerk during transportation. Hence impact of force reduces on China wares.
23. Less reaction force.

24. In addition to the frictional force, a component of reaction force also provides centripetal force.
25. Weight of the water and bucket is used up in providing the necessary centripetal force at the top of the circle.
26. So that in addition of the frictional force, the horizontal component of the normal reaction also provides the necessary centripetal forces.
27. Impulse and change in momentum are along the same direction. Therefore angle between these two vectors is zero.
28. Due to inertia of motion.

29. As $F \propto \frac{dP}{dt}$

when $F = 0, \frac{dP}{dt} = 0$ so $P = \text{constant}$

30. $F = 36 \text{ dyne}$ at an angle of 60°
 $F_x = F \cos 60^\circ = 18 \text{ dyne}$
 $F_x = ma_x$

So $a_x = \frac{F_x}{m} = 1 \text{ cm/s}^2$

31. $h = ut + \frac{1}{2}gt^2$

find a by differentiating h twice w.r.t.

$$a = g$$

as $F = ma$ so $F = mg$ (answer)

32. As $F = ma$ so $F = -kx = ma$

$$a = \frac{-kx}{m}$$

for $x = 20 \text{ cm}, \Rightarrow a = -10 \text{ m/s}^2$

33. Initial momentum = 0

using conservation of linear momentum

$$mv + MV = 0$$

$$V = \frac{-mv}{M}$$

$\Rightarrow V = 2.5 \text{ m/s}$

34. When there is no friction, the block slides down the inclined plane with acceleration.

$$a = g \sin \theta$$

when there is friction, the downward acceleration of the block is

$$a' = g (\sin \theta - \mu \cos \theta)$$

As the block slides a distance d in each case so

$$d = \frac{1}{2} at^2 = \frac{1}{2} a' t'^2$$

$$\frac{a}{a'} = \frac{t'^2}{t^2} = \frac{(nt)^2}{t^2} = n^2$$

or
$$\frac{g \sin \theta}{g(\sin \theta - \mu \cos \theta)} = n^2$$

Solving, we get (Using $\theta = 45^\circ$)

$$\mu = 1 - \frac{1}{n^2}$$

35. (i)

weight

$$\begin{aligned} R &= m(g - a) \\ &= 49 \text{ N} \end{aligned}$$

so

$$m = \frac{49}{9.8} = 5 \text{ kg}$$

$$R = 5(9.8 - 5)$$

$$R = 24 \text{ N}$$

- (ii)

$$R = m(g + a)$$

$$R = 5(9.8 + 5)$$

$$R = 74 \text{ N}$$

(iii) as $a = 0$ so $R = mg = 49 \text{ N}$

38. (i) Parabolic, (ii) vertically downwards

41.

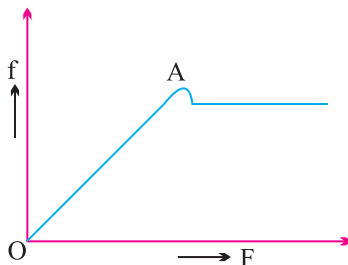

Up to point A, $f = F$ (So long as block is stationary)

beyond A, when F increases, block starts moving f remains constant.

42. (i) Thread AB breaks down
 (ii) CD will break.

43.

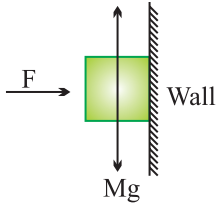

For the block not to fall $f = Mg$

But

$$f = \mu R = \mu F \text{ so}$$

$$\mu F = Mg$$

$$F = \frac{Mg}{\mu}.$$

44. Use

$$F = ma$$

$$a = \frac{v - u}{t} = \frac{200 - 0}{4} = 50 \text{ cm/s}^2$$

$$F = 500 \times 50 = 25,000 \text{ dyne.}$$

45. $F = 98 \text{ N}$, $R = 45 \times 9.8 = 441 \text{ N}$

$$\mu^2 = \frac{F}{R} = 0.22$$

Angle of friction $\theta = \tan^{-1} \mu = \tan^{-1} 0.22 = 12^\circ 24'$

46.

Force of friction = 0.5 N per quintal

$$f = 0.5 \times 2000 = 1000 \text{ N}$$

$$m = 2000 \text{ quintals} = 2000 \times 100 \text{ kg}$$

$$\sin \theta = \frac{1}{50}, a = 2 \text{ m/s}^2$$

In moving up an inclined plane, force required against gravity

$$= mg \sin \theta = 39200 \text{ N}$$

And force required to produce acceleration = ma

$$= 2000 \times 100 \times 2 = 40,000 \text{ N}$$

$$\text{Total force required} = 1000 + 39,200 + 40,000$$

$$= 440200 \text{ N.}$$

47. Suppose, a = acceleration produced if m_1 and m_2 are tied together,

$$F = 100 \text{ N}$$

Let a_1 and a_2 be the acceleration produced in m_1 and m_2 , respectively.

$$\therefore a_1 = 10 \text{ ms}^{-2}, a_2 = 20 \text{ ms}^{-2} \text{ (given)}$$

$$\text{Again } m_1 = \frac{F}{a_1} \text{ and } m_2 = \frac{F}{a_2}$$

$$\Rightarrow m_1 = \frac{100}{10} = 10 \text{ ms}^{-2}$$

$$\text{and } m_2 = \frac{100}{20} = 5 \text{ ms}^{-2}$$

$$\therefore m_1 + m_2 = 10 + 5 = 15$$

$$\text{So, } a = \frac{F}{m_1 + m_2} = \frac{100}{15} = \frac{20}{3} \\ = 6.67 \text{ ms}^{-2}$$

48. Case (a) : $a = \left(\frac{2m - m}{2m + m} \right) g$

$$a = \frac{g}{3}$$

Case (b) : FBD of mass m

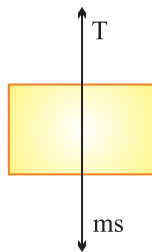

$$ma' = T - mg$$

$$ma' = 2mg - mg$$

$$\Rightarrow ma' = mg$$

$$a' = g$$

So in case (b) acceleration of m is more.

49. (a) For $t < 0$. No force as Particles is at rest.

For $t > 4s$, No force again particle comes at rest.

For $0 < t < 4s$, as slope of OA is constant so velocity constant *i.e.*, $a = 0$, so force must be zero.

(b) Impulse at $t = 0$

Impulse = change in momentum

$$I = m(v - u) = 4(0 - 0.75) = 3 \text{ kg ms}^{-1}$$

Impulse at $t = 4\text{s}$

$$I = m(v - u) = 4(0 - 0.75) = -3 \text{ kg ms}^{-1}$$

50. Free body diagram of the block

$$30 - T = 3a \quad \dots(\text{i})$$

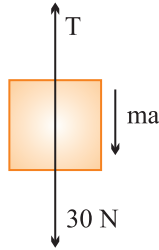

Free body diagram of the trolley

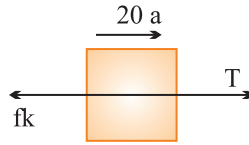

$$T - f_k = 20a \quad \dots(\text{ii})$$

where

$$f_k = \mu_k N = 0.04 \times 20 \times 10 = 8 \text{ N}$$

Solving (i) & (ii),

$$a = 0.96 \text{ m/s}^2 \text{ and } T = 27.2 \text{ N}$$

51. All the blocks move with common acceleration a under the force $F = 60 \text{ N}$.

$$F = (m_1 + m_2 + m_3)a$$

$$a = \frac{F}{(m_1 + m_2 + m_3)} = 1 \text{ m/s}^2$$

To determine, $T_1 \rightarrow$ Free body diagram of mass m_1 .

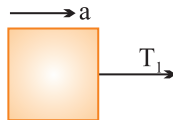

$$T_1 = m_1 a = 10 \times 1 = 10 \text{ N}$$

To determine, T_2 – Free body diagram of m_3 .

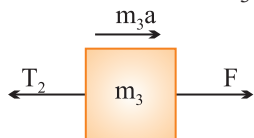

$$F - T_2 = m_3 a$$

Solving, we get $T_2 = 30 \text{ N}$

52. Force on the box due to accelerated motion of the truck

$$F = ma = 40 \times 2 = 80 \text{ N}$$

(in forward direction)

Reaction on the box, $F' = F = 80 \text{ N}$ (in backward direction)

Force of limiting friction, $f = \mu R = 0.15 \times 40 \times 10 = 60 \text{ N}$

Net force on the box in backward direction is $P = F' - f$

$$= 80 - 60 = 20 \text{ N}$$

Backward acceleration in the box $= a = \frac{P}{m} = \frac{20}{40} = 0.5 \text{ ms}^{-1}$

$t =$ time taken by the box to travel $s = 5 \text{ m}$ and falls off the truck, then from

$$s = ut + \frac{1}{2} at^2$$

$$5 = 0 \times t + \frac{1}{2} \times 0.5 \times t^2$$

$$t = 4.47 \text{ s}$$

If the truck travels a distance x during this time

$$\text{then } x = 0 \times 4.34 + \frac{1}{2} \times 2 \times (4.471)^2$$

$$x = 19.98 \text{ m}$$

53. Use

$$s = ut + \frac{1}{2} at^2$$

$$a = \frac{2s}{t^2} \text{ as } u = 0$$

$$\mu = \frac{g \sin \theta - a}{g \cos \theta}$$

Putting the value and solving, $\mu = 0.11$

54. (a) Force on the floor of the helicopter by the crew and passengers

$$= \text{apparent weight of crew and passengers}$$

$$= 500 (10 + 15)$$

$$= 12500 \text{ N}$$

(b) Action of rotor of helicopter on surrounding air is Obviously vertically downwards, because helicopter rises on account of reaction of this force. Thus force of action

$$= (2000 + 500) (10 + 15)$$

$$= 2500 \times 25$$

$$= 62,500 \text{ N}$$

(c) Force on the helicopter due to surrounding air is obviously a reaction. As action and reaction are equal and opposite, therefore

$$\text{Force of reaction } F' = 62,500 \text{ vertically upwards.}$$

55. (a) When the box just starts sliding

$$\mu = \tan \theta$$

or $\theta = \tan^{-1} \mu$

(b) Force acting on the box down the plane

$$= mg (\sin \alpha - \mu \cos \alpha)$$

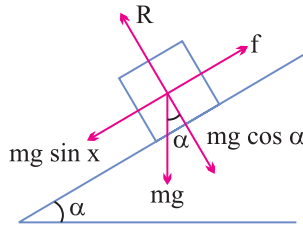

(c) Force needed $mg (\sin \alpha + \mu \cos \alpha)$

(d) Force needed $= mg (\sin \alpha + \mu \cos \alpha) + ma$.

56. According Newton's second law of motion

(i) $T_1 - (m_1 + m_2)g = (m_1 + m_2)a$

$$T_1 = (m_1 + m_2)(a + g)$$

$$= (5 + 3) (2 + 9.8)$$

$$T_1 = 94.4 \text{ N}$$

$$\begin{aligned}
 \text{(ii)} \quad T_2 - m_2 g &= m_2 a \\
 T_2 &= m_2 (a + g) \\
 T_2 &= 3(2 + 9 \cdot 8) \\
 T_2 &= 35 \cdot 4 \text{ N}
 \end{aligned}$$

57. Using Resolution of forces 1N and 2N and then applying laws of vector addition.

Calculate for F_1 & F_2 .

$$F_1 = \frac{1}{\sqrt{2}} \cdot \text{N}, F_2 = \frac{3}{\sqrt{2}} \text{N}.$$

58. Given m = mass of bullet = 50 gm = 0.50 kg

M = mass of tiger = 60 kg

v = Velocity of bullet = 150 m/s

V = Velocity of tiger = -10 m/s

(\therefore It is coming from opposite direction n = no. of bullets fired per second at the tiger so as to stop it.)

$$P_i = 0, \text{ before firing} \quad \dots\text{(i)}$$

$$P_f = n(mv) + MV \quad \dots\text{(ii)}$$

\therefore From the law of conservation of momentum,

$$P_i = P_f$$

$$\Rightarrow 0 = n(mv) + MV$$

$$\Rightarrow n = \frac{MV}{mv}$$

$$= \frac{-60 \times (-10)}{0.05 \times 150} = 80.$$

59.

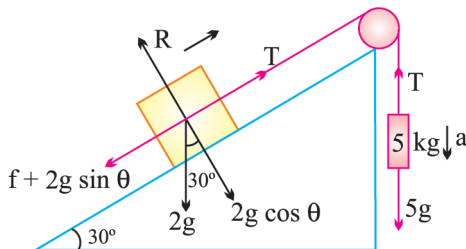

Let a be the acceleration of the system and T be the Tension in the string.
Equations of motions for 5 kg and 2 kg blocks are

$$5g - T = 5a \quad \dots(1)$$

$$T - 2g \sin \theta - f = 2a \quad \dots(2)$$

where

f = force of limiting friction

$$= \mu R = \mu mg \cos \theta = 0.3 \times 2g \times \cos 30^\circ$$

Solving (1) & (2),

$$a = 4.87 \text{ m/s}^2$$

$$T = 24.65 \text{ N.}$$

ASSERTION - REASON BASED ANSWERS

1. (a) 2. (b) 3. (c) 4. (a) 5. (d)
6. (c) 7. (d) 8. (b) 9. (c) 10. (b)

CASE STUDY BASED ANSWERS

1. i. (d)
ii. (c) Because acceleration is zero, observed weight = actual weight
iii. (b) Net force = $mg - R = m\left(\frac{g}{4}\right)$
$$\Rightarrow R = \frac{3mg}{4} = \frac{3 \times 60}{4} \text{ g}$$
$$= 45 \text{ gN.}$$

iv. (b) Net force = ~~mg~~ - ~~R~~ = ~~mg~~
 $R = 0 \text{ N}$
v. (b) Net force = $R - mg = \frac{mg}{2}$
$$\Rightarrow R = \frac{3mg}{2} = \frac{3 \times 60}{2} \text{ g}$$
$$= 90 \text{ gN.}$$
2. i. (a)
ii. (c)
iii. (d)

iv. (d) $ma \leq f$ $f = \mu_s R$
 $ma \leq \mu_s R$ $a_{\max} = \mu_s g$
 $ma \leq \mu_s mg$ $a \leq \mu_s g$ $= 0.15 \times 10 = 1.5 \text{ ms}^{-2}$

v. (b) Let the mass of block C is m

For block A, $R = (m_1 + m)$

$T = fs = \mu R = \mu(m + m_1)g$

To avoid slipping of A, For block B

$T = m_2 g$

or $\mu(m + m_1)g = m_2 g$

$0.2(m + 10) = 5 \implies m = 15 \text{ kg}$

3. i. (b)

ii. (c) Impulse = change in momentum = $mv - mu$
 $= m(v - u) = 0.15[12 - (-12)]$
 $= 3.6 \text{ Ns}$

iii. (a) Impulse = change in momentum = $m(v - u)$
 $= \left(0 - \frac{3}{4}\right) = -3 \text{ kg ms}^{-1}$
 $v = 0 \text{ m/s}, u = \frac{3}{4} \text{ m/s}$

iv. (d) Impulse = change in momentum = $m(v - u)$
 $= 0.04 [-0.01 - 0.01]$
 $= -8 \times 10^{-4} \text{ kg m/s}$

$v = \frac{0 - 2}{4 - 2} = -1 \text{ cm/s} = -0.01 \text{ m/s},$

$u = \frac{2 - 0}{2 - 0} = 1 \text{ cm/s} = 0.01 \text{ m/s}$

v. (b) Impulse = change in momentum
 $= mv \cos 60^\circ - (-mv \cos 60^\circ)$
 $= 2mv \cos 60^\circ = 2 \times 3 \times 10 \times \frac{1}{2} = 30 \text{ Ns}$

4. i. (a) ii. (d) iii. (b) iv. (c) v. (a)

LAWS OF MOTION (MCQ's)

1. The maximum velocity (in m/s) with which a car driver must transverse a flat curve of radius 150 m and coefficient of friction 0.6 to avoid skidding is

(a) 60	(b) 30
(c) 15	(d) 25

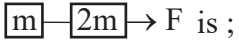
2. The tension in the string shown in figure  is ;

(a) $F/3$	(b) $F/6$
(c) $F/2$	(d) $2F$

3. A particle moves in x-y plane under the action of force \vec{F} such that the value of its linear momentum (\vec{p}) at any instant t is $p_x = 2 \cos t$ and $p_y = 2 \sin t$. The angle θ between \vec{F} and \vec{p} at a given time t will be-

(a) 90°	(b) 0°
(c) 180°	(d) 30°

4. Three forces $\vec{A} = \hat{i} + \hat{j} - \hat{k}$, $\vec{B} = 2\hat{i} - \hat{j} + 3\hat{k}$ and \vec{C} are acting on a body to keep it in equilibrium. Then \vec{C} is

(a) $-(3\hat{i} + 4\hat{k})$	(b) $-(4\hat{i} + 3\hat{k})$
(c) $3\hat{i} + 4\hat{k}$	(d) $2\hat{i} + 3\hat{k}$

5. The objects at rest suddenly explodes into three parts with the mass ratio 2:1:1. The parts of equal masses moves at right angles to each other with equal speeds. The speed of the third part after the explosion will be

(a) $2v$	(b) $\frac{v}{\sqrt{2}}$
(c) $\frac{v}{2}$	(d) $\sqrt{2}v$

6. Two Iron blocks of equal masses but with double surface area slide down an Inclined plane with coefficient of friction μ . If the first block with surface area A experience a friction force f , then the second block with surface area $2A$ will experiences a frictional force.

(a) $f/2$	(b) f	(c) $2f$	(d) $4f$
-----------	---------	----------	----------

7. A body of mass M starts sliding down an Inclined plane where critical angle is $\angle ACB=30^\circ$ as shown in figure, the coefficient of friction will be

(a) $\frac{Mg}{\sqrt{3}}$

(b) $\sqrt{3} Mg$

(c) $\sqrt{3}$

(d) None of these

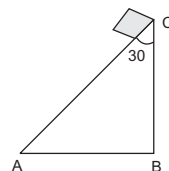

8. Three block of masses m_1 , m_2 & M_3 are connected by mass less stings as shown on a frictionless table.

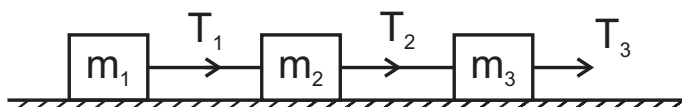

They are pulled with a force $T_3 = 40\text{N}$, If $m_1=10\text{ kg}$, $m_2=6\text{ kg}$, & $m_3=4\text{ kg}$, then tension T_2 will be

(a) 20 N

(b) 40 N

(c) 10

(d) 32 N

9. If the tension in the cable supporting an elevator is equal to the weight of elevator, the elevator may be

(a) going up with increasing speed

(b) going down with increasing speed

(c) going up with uniform speed

(d) elevator falls freely under gravity

10. A graph is drawn with a force along y-axis and time along x-axis. The area under the graph represent–

(a) Momentum

(b) Couple

(c) Moment of the force

(d) Impulse of the force

11. In a game of tug of wars, a condition of equilibrium exists. Both the team pull the rope with a force of 10^4N . The tension in the rope is –

(a) 10^4 N

(b) 10^8 N

(c) 0 N

(d) $2 \times 10^4\text{ N}$

12. A bullet of mass m moving with a speed v strikes a wooden block of mass M & gets embedded into the block. The final speed is

(a) $\sqrt{\frac{M}{M+m}} V$ (b) $\sqrt{\frac{m}{M+m}} V$
 (c) $\frac{m}{M+m} V$ (d) $\frac{V}{2}$

13. The pulley & strings shown in figure are smooth and of negligible mass. For the system to remain in equilibrium, the angle θ should be

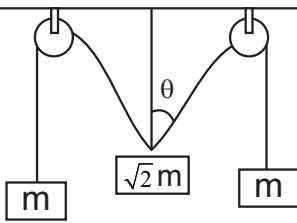

- (a) 0° (b) 30°
 (c) 45° (d) 60°
14. If two forces are acting at a point such that the magnitude of each force is $2N$ and the magnitude of their resultant is also $2N$, then the angle between the two forces is
- (a) 120° (b) 60°
 (c) 90° (d) 0°
15. The dimensions of action are
- (a) $[M L T^{-2}]$ (b) $[M^2 L T^{-3}]$
 (c) $[M L T^{-1}]$ (d) $[ML^2 T^{-1}]$

16. Which of the four arrangements in the figure correctly shows the vector addition of two forces F_1 & F_2 to yield the third force F_3 ?

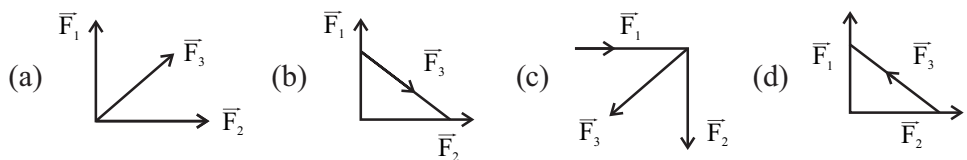

17. A car when passes through a bridge exerts a force on it which is equal to

(a) $mg + \frac{mv^2}{r}$

(c) $\frac{mv^2}{r}$

(b) $mg - \frac{mv^2}{r}$

(d) None of these

18. In the figure given, the position-time graph of a particle of mass 0.1 kg is shown the impulse at $t = 2s$ is

(a) 0.2 kg m/s

(b) -0.2 kg m/s

(c) 0.1 kg m/s

(d) -0.4 kg m/s

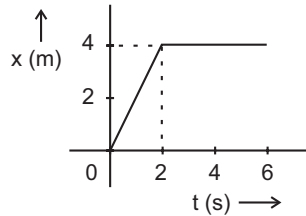

19. A particle revolves round a circular path. The acceleration of the particle is inversely proportional to—

(a) radius

(b) velocity

(c) mass of particle

(d) both (b) & (c)

20. If Maximum and minimum values of the resultant of two forces acting at a point are 7N and 3N respectively, the smaller force is equal to

(a) 4N

(b) 5N

(c) 3N

(d) 2N

Answer Key :

1. (b) 2. (a) 3. (a) 4. (a) 5. (b) 6. (b)

7. (c) 8. (d) 9. (c) 10. (d) 11. (a) 12. (c)

13. (c) 14. (a) 15. (a) 16. (a) 17. (c) 18. (b)

19. (a) 20. (d)

HINTS AND EXPLANATIONS :

1. $v = \sqrt{\mu rg} = \sqrt{0.6 \times 150 \times 10} = 30 \text{ m/s}$

2. $2ma = F - T$ — (1) Solve $T = F/3$

$ma = T$ — (2)

3. $p = \sqrt{px^2 + py^2} = \sqrt{4\cos^2 t + 4\sin^2 t} = 2$ (constant), As p remains constant, \vec{F} acts at right angle to \vec{p} .

4. Since body is in equilibrium

$$\vec{A} + \vec{B} + \vec{C} = \vec{O}$$

$$\begin{aligned}\vec{C} &= -(\vec{A} + \vec{B}) = -[\hat{i} + \hat{j} + \hat{k} + 2\hat{i} - \hat{j} + 3\hat{k}] \\ &= -[3\hat{i} + 0\hat{j} + 4\hat{k}] = -(3\hat{i} + 4\hat{k})\end{aligned}$$

5. Resultant momentum of two part of equal mass

$$p_1 = \sqrt{(mv)^2 + (mv)^2} = \sqrt{2} mv$$

ut v^1 = speed of third part of mass 2 m

Acc. to Law of conservation of momentum

$$(2m)v^1 = \sqrt{2} m v$$

$$v^1 = \frac{\sqrt{2} v}{2} = \frac{v}{\sqrt{2}}$$

6. Frictional force is independent of area of contact.

7. $\mu = \tan 60^\circ = \sqrt{3}$

8. Net acceleration $= \frac{T_3}{m_1 + m_2 + m_3} = \frac{40}{20} = 2 \text{ m/s}^2$

$$T_2 = (m_1 + m_2) a = 16 \times 2 = 32 \text{ N}$$

9. Impulse $= \int F dt$

12. By law of conservation of momentum

$$mv + M(0) = (m + M) V$$

$$V = \frac{m v}{m + M}$$

13. For equilibrium of mass m, $T = mg$ — (1)

For equilibrium of mass $\sqrt{2} m$

$$2T \cos \theta = \sqrt{2} mg \text{ — (2)}$$

Solve (1) & (2)

$$\cos \theta = \frac{1}{\sqrt{2}}, \quad \theta = 45^\circ.$$

14. $P = Q = 2\text{N}$, $R = 2\text{N}$

$$R^2 = P^2 + Q^2 + 2PQ \cos \theta$$

$$4 = 4 + 4 + 2(4) \cos \theta$$

$$\cos \theta = \frac{-4}{8} = \frac{-1}{2}, \quad \theta = 120^\circ$$

15. Action = Force

$$= [M L T^{-2}]$$

17. $F = mg - \frac{mv^2}{r}$

18. Impulse

$$= \text{change in momentum}$$

$$= m(v-u)$$

$$= 0.1 (0-2) = -0.2 \text{ kg m/s}$$

19. $a = \frac{V^2}{r}$

$$a \propto \frac{1}{r}$$

20. $F_{\text{max.}} = P + Q = 7\text{N}$ ——— (1)

$$F_{\text{min.}} = P - Q = 3\text{N}$$
 ——— (2)

From (1) & (2)

$$P + Q = 7$$

$$P + Q = 7$$

$$P - Q = 3$$

$$5 + Q = 7$$

$$2P = 10$$

$$Q = 2 \text{ N}$$

$$\boxed{P = 5\text{N}}$$

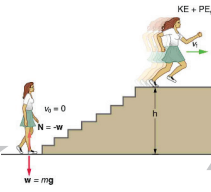

Unit - 4

Work, Energy And Power

4.1 Introduction

Work is said to be done when a force applied on the body displaces the body through a certain distance in the direction of force.

4.2 Work Done by a Constant Force

Let a constant force F be applied on the body such that it makes an angle θ with the horizontal and body is displaced through a distance s .

Then work done by the force in displacing the body through a distance s is given by

$$W = (F \cos \theta) s = Fs \cos \theta \Rightarrow W = (F \cos \theta) s = Fs \cos \theta$$

$$W = \vec{F} \cdot \vec{s}$$

4.3 Nature of Work Done

Positive work	Negative work
Positive work means that force (or its component) is parallel to displacement $0^\circ \leq \theta < 90^\circ$	Negative work means that force (or its component) is opposite to displacement <i>i.e.</i> , $90^\circ < \theta \leq 180^\circ$

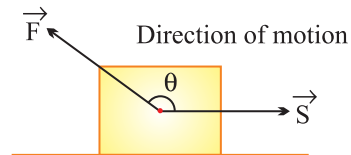
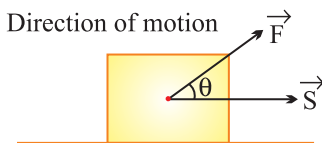

The positive work signifies that the external force favours the motion of the body.

The negative work signifies that the force opposes the motion of the body.

4.4 Work Done by a Variable Force

When the magnitude and direction of a force varies with position, the work done by such a force for an infinite small displacement is given by

$$dW = \vec{F} \cdot d\vec{s}.$$

The total work done in going from A to B is $W = \int_A^B \vec{F} \cdot d\vec{s} = \int_A^B (F \cos \theta) ds$.

Area under force displacement curve with proper algebraic sign represents work done by the force.

4.5 Work Depends on Frame of Reference

With change of frame of reference (inertial) force does not change while displacement may change. So the work done by a force will be different in different frames.

Examples : If a person is pushing a box inside a moving train, the work done in the frame of train will be $\vec{F} \cdot \vec{s}$ while in the frame of earth will be $\vec{F} \cdot (\vec{s} + \vec{s}_0)$ where \vec{s}_0 is the displacement of the train relative to the ground.

4.6 Energy

The energy of a body is defined as its capacity for doing work.

- (1) It is a scalar quantity.
- (2) Dimension : $[ML^2 T^{-2}]$ it is same as that of work or torque.
- (3) Units : Joule [S.I.], erg [C.G.S.]

Practical units : electron volt (eV), Kilowatt hour (KWh), Calories (Cal)

Relation between different units :

$$1 \text{ Joule} = 10^7 \text{ erg}$$

$$1 \text{ eV} = 1.6 \times 10^{-19} \text{ Joule}$$

$$1 \text{ KWh} = 3.6 \times 10^6 \text{ Joule}$$

$$1 \text{ Calorie} = 4.18 \text{ Joule}$$

- (4) Mass energy equivalence : The relation between the mass of a particle m and its equivalent energy is given as $E = mc^2$ where c = velocity of light in vacuum.

4.7 Kinetic Energy

The energy possessed by a body by virtue of its motion is called kinetic energy.

Let m = mass of the body, v = velocity of the body then $K.E. = \frac{1}{2}mv^2$.

(1) **Kinetic energy depends on frame of reference** : The kinetic energy of a person of mass m , sitting in a train moving with speed v , is zero in the frame of train but $\frac{1}{2}mv^2$ in the frame of the earth.

(2) **Work-energy theorem** : It states that work done by a force acting on a body is equal to the change produced in the kinetic energy of the body.

This theorem is valid for a system in presence of all types of forces (external or internal, conservative or non-conservative).

(3) **Relation of kinetic energy with linear momentum** : As we know

$$E = \frac{p^2}{2m} \Rightarrow p = \sqrt{2mE}$$

(4) **Various graphs of kinetic energy**

4.8 Kinetic Energy

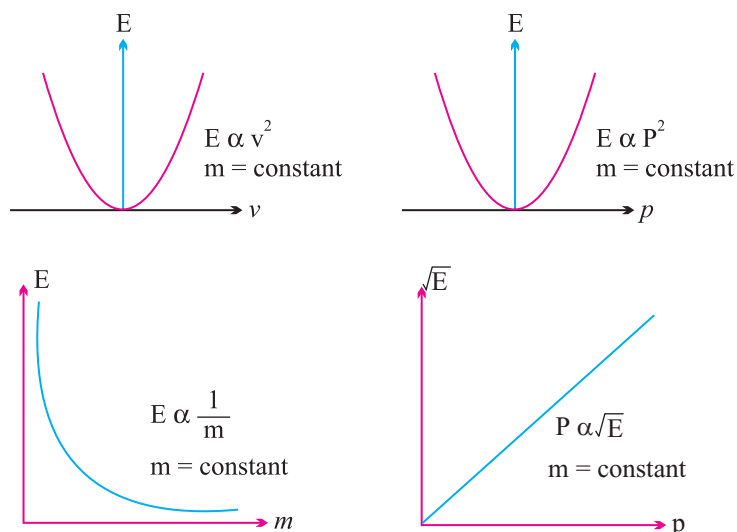

4.9 Potential Energy

Potential energy is defined only for conservative forces. In the space occupied by conservative forces every point is associated with certain energy which is called the energy of position or potential energy. Potential energy generally

are of three types : Elastic potential energy and Gravitational potential energy etc.

- (1) **Change in potential energy** : Change in potential energy between any two points is defined in terms of the work done by the force in displacing the particle between these two points without any change in kinetic energy.

$$U_2 - U_1 = -\int_1^2 \vec{F} \cdot d\vec{r} = -W \quad \dots(1)$$

- (2) **Potential energy curve** : A graph plotted between the potential energy of a particle and its displacement from the centre of force is called potential energy curve. Negative gradient of the potential energy gives force.

$$-\frac{dU}{dx} = F$$

- (5) **Types of equilibrium** : If net force acting on a particle is zero, it is said to be in equilibrium.

For equilibrium, $\frac{dU}{dx} = 0$, but the equilibrium of particle can be of three types :

Stable	Unstable	Neutral
When a particle is displaced slightly from a position, then a force acting on it brings it back to the initial position, it is said to be in stable equilibrium position.	When a particle is displaced slightly from a position, then a force acting on it tries to displace the particle further away from the equilibrium position, it is said to be in unstable equilibrium.	When a particle is slightly displaced from a position then it does not experience any force acting on it and continues to be in equilibrium in the displaced position, it is said to be in neutral equilibrium.
Potential energy is minimum.	Potential energy is maximum.	Potential energy is constant.
$F = -\frac{dU}{dx} = 0$	$F = -\frac{dU}{dx} = 0$	$F = \frac{dU}{dx} = 0$
$\frac{d^2U}{dx^2} = \text{positive}$	$\frac{d^2U}{dx^2} = \text{negative}$	$\frac{d^2U}{dx^2} = 0$
<i>i.e.</i> , rate of change of $\frac{dU}{dx}$ is positive.	<i>i.e.</i> , rate of change of $\frac{dU}{dx}$ is negative.	<i>i.e.</i> , rate of change of $\frac{dU}{dx}$ is zero.
<i>Example</i> : A marble placed at the bottom of a hemispherical bowl.	<i>Example</i> : A marble balanced on top of a hemispherical bowl.	<i>Example</i> : A marble placed on horizontal table.

4.10 Elastic Potential Energy

- (1) **Restoring force and spring constant :** When a spring is stretched or compressed from its normal position ($x = 0$) by a small distance x , a restoring force is produced in the spring to bring it to the normal position. According to Hooke's law this restoring force is proportional to the displacement x and its direction is always opposite to the displacement.

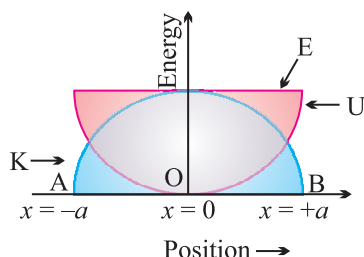

$$i.e., \quad \vec{F} \propto \vec{x}$$

$$or \quad \vec{F} = k \vec{x} \quad \dots(i)$$

where k is called spring constant.

- (2) **Expression for elastic potential energy :**

$$\text{Elastic potential energy } U = \frac{1}{2} kx^2 = \frac{1}{2} Fx = \frac{F^2}{2k}$$

Note :

- If spring is stretched from initial position x_1 to final position x_2 then work done = Increment in elastic potential energy

$$= \frac{1}{2} k(x_2^2 - x_1^2)$$

- (3) **Energy graph for a spring :** It mean kinetic energy changes parabolically w.r.t. position but total energy remain always constant irrespective to position of the mass.

4.11 Law of Conservation of Energy

- (1) **Law of conservation of energy :** For an isolated system or body in presence of conservative forces the sum of kinetic and potential energies at any point remains constant throughout the motion. It does not depends upon time. This is known as the law of conservation of mechanical energy.
- (2) **Law of conservation of total energy :** If the forces are conservative and non-conservative both, it is not the mechanical energy alone which

is conserved, but it is the total energy, may be heat, light, sound or mechanical etc., which is conserved.

4.12 Power

Power of a body is defined as the rate at which the body can do the work.

$$\text{Average power (P}_{av}\text{)} = \frac{\Delta W}{\Delta t} = \frac{W}{t}$$

$$\text{Instantaneous power (P}_{inst.}\text{)} = \frac{dW}{dt} = \frac{\vec{F} \cdot d\vec{s}}{dt}$$

$$[\text{As } dW = \vec{F} \cdot d\vec{s}]$$

$$P_{inst} = \vec{F} \cdot \vec{v}$$

i.e., power is equal to the scalar product of force with velocity.

(1) Dimension : $[P] = [ML^2T^{-3}]$

(2) Units : Watt or Joule/sec [S.I.]

Practical Units : Kilowatt (kW), Mega watt (MW) and Horse power (*hp*)

Relations between different units : 1 watt = 1 Joule/sec = 10^7 erg/sec

$$1hp = 746 \text{ Watt}$$

(3) The slope of work time curve gives the instantaneous power. As $P = dW/dt = \tan \theta$

(4) Area under power time curve gives the work done as $P = \frac{dW}{dt}$

$$\therefore W = \int P dt$$

$$\therefore W = \text{Area under } P - t \text{ curve}$$

4.13 Collision

Collision is an isolated event in which a strong force acts between two or more bodies for a short time as a result of which the energy and momentum of the interacting particle change.

In collision particles may or may not come in real touch.

(3) **Types of collision** : (i) On the basis of conservation of kinetic energy.

Perfectly Elastic collision	Inelastic collision	Perfectly inelastic collision
If in a collision, kinetic energy after collision is equal to kinetic energy before collision, the collision is said to be perfectly elastic.	If in a collision kinetic energy after collision is not equal to kinetic energy before collision, the collision is said to be inelastic.	If in a collision two bodies stick together or move with same velocity after the collision, the collision is said to be perfectly inelastic.
Coefficient of restitution $e = 1$	Coefficient of restitution $0 < e < 1$	Coefficient of restitution $e = 0$
$(KE)_{\text{final}} = (KE)_{\text{initial}}$	Here kinetic energy appears in other forms. In some cases $(KE)_{\text{final}} < (KE)_{\text{initial}}$ such as when initial KE is converted into internal energy of the product (as heat, elastic or excitation) while in other cases $(KE)_{\text{final}} > (KE)_{\text{initial}}$ such as when internal energy stored in the colliding particles is released.	The term 'perfectly inelastic' does not necessarily mean that all the initial kinetic energy is lost, it implies that the loss in kinetic energy is as large as it can be. (Consistent with momentum conservation).
Examples : (1) Collision between atomic particles (2) Bouncing of ball with same velocity after the collision with earth.	Examples : (1) Collision between two billiard balls. (2) Collision between two automobile on a road. In fact all majority of collision belong to this category.	Example : Collision between a bullet and a block of wood into which it is fired. When the bullet remains embedded in the block.

4.14 Perfectly Elastic Head on Collision

Let two bodies of masses m_1 and m_2 moving initial velocities u_1 and u_2 in the same direction they collide such that after collision their final velocities are v_1 and v_2 respectively.

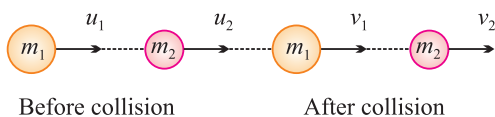

According to law of conservation of momentum and conservation of kinetic energy.

Note :

- The ratio of relative velocity of separation and relative velocity of approach is defined as coefficient of restitution.

$$e = \frac{v_2 - v_1}{u_1 - u_2} \text{ or } v_2 - v_1 = e(u_1 - u_2).$$

- For perfectly elastic collision $e = 1$

$$\therefore v_2 - v_1 = u_1 - u_2 \text{ [As shown in eq. (vi)]}$$

- For perfectly inelastic collision $e = 0$

$$\therefore v_2 - v_1 = 0 \text{ or } v_2 = v_1$$

It means that two body stick together and move with same velocity.

- For inelastic collision $0 < e < 1$

$$\therefore v_2 - v_1 = (u_1 - u_2)$$

In short we can say that e is the degree of elasticity of collision and it is dimension less quantity.

$$v_1 = \left(\frac{m_1 - m_2}{m_1 + m_2} \right) u_1 + \frac{2m_2 u_2}{m_1 + m_2} \quad \dots(\text{vii})$$

$$v_2 = \left(\frac{m_2 - m_1}{m_1 + m_2} \right) u_1 + \frac{2m_1 u_1}{m_1 + m_2} \quad \dots(\text{viii})$$

- When two bodies of equal masses undergo head on elastic collision, their velocities get interchanged.

(2) Kinetic energy transfer during head on elastic collision : Fractional decrease in kinetic energy

$$\frac{\Delta K}{K} = \frac{4m_1 m_2}{(m_1 - m_2) + 4m_1 m_2} \quad \dots(\text{iv})$$

Note :

- Greater the difference in masses less will be transfer of kinetic energy and vice versa.
- Transfer of kinetic energy in head on elastic collision (when target is at rest) is maximum when the masses of particles are equal.

4.15 Motion in Vertical Circle

This is an example of non-uniform circular motion. In this motion body is under the influence of gravity of earth.

- (1) **Velocity at any point on vertical loop :** If u is the initial velocity imparted to body at lowest point then, velocity of body at height h is given by

$$v = \sqrt{u^2 - 2gh} = \sqrt{u^2 - 2gl(1 - \cos\theta)}$$

where l is the length of the string.

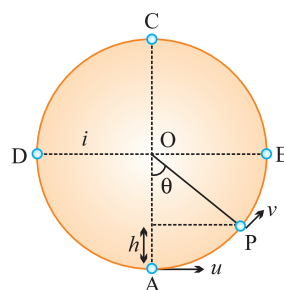

- (2) **Tension at any point on vertical loop :** Tension at general point P,

$$T = mg \cos\theta + \frac{mv^2}{l}$$

- (3) **Various conditions for vertical motion :**

Velocity at lowest point	Condition
$u_A > \sqrt{5gl}$	Tension in the string will not be zero at any of the point and body will continue the circular motion.
$u_A = \sqrt{5gl}$,	Tension at highest point C will be zero and body will just complete the circle.
$\sqrt{2gl} < u_A < \sqrt{5gl}$,	Particle will not follow circular motion. Tension in string become zero somewhere between points B and C whereas velocity remain positive. Particle leaves circular path and follow parabolic trajectory.
$u_A = \sqrt{2gl}$	Both velocity and tension in the string becomes zero between A and B and particle will oscillate along semi-circular path.
$u_A < \sqrt{2gl}$	Velocity of particle becomes zero between A and B but tension will not be zero and the particle will oscillate about the point A.

(6) Various quantities for a critical condition in a vertical loop at different positions :

Quantity	Point A	Point B	Point C	Point D	Point P
Linear velocity (v)	$\sqrt{5gl}$	$\sqrt{3gl}$	\sqrt{gl}	$\sqrt{3gl}$	$\sqrt{gl(3+2\cos\theta)}$
Angular velocity (ω)	$\sqrt{\frac{5g}{l}}$	$\sqrt{\frac{3g}{l}}$	$\sqrt{\frac{g}{l}}$	$\sqrt{\frac{3g}{l}}$	$\sqrt{\frac{g}{l}(3+2\cos\theta)}$
Tension in String (T)	$6mg$	$3mg$	0	$3mg$	$3mg(1+\cos\theta)$
Kinetic Energy (KE)	$\frac{5}{2}mgl$	$\frac{3}{2}mgl$	$\frac{1}{2}mgl$	$\frac{3}{2}mgl$	$\frac{mv^2}{2} - 5mg = 0$
Potential Energy (PE)	0	mgl	$2mgl$	mgl	$mgl(1-\cos\theta)$
Total Energy (TE)	$\frac{5}{2}mgl$	$\frac{5}{2}mgl$	$\frac{5}{2}mgl$	$\frac{5}{2}mgl$	$\frac{5}{2}mgl$

VERY SHORT ANSWER QUESTIONS (1 MARK)

1. Define the conservative and non-conservative forces. Give examples of each.
2. A light and heavy body have same linear momentum. Which one has greater kinetic energy?
3. How much work is done by a coolie walking a horizon lat platform with a load on his head?
4. A body is moving along a circular path. How much work is done by the centripetal force ?
5. Which spring has greater value of spring constant – a hard spring or a delicate spring ?
6. Two bodies stick together after collision. What type of collision is in between these two bodies ?
7. State the two conditions under which a force does no work ?
8. How will the momentum of a body changes if its K.E. is doubled ?
9. K.E. of a body is increased by 300 %. Find the % increase in its momentum ?
10. A light and a heavy body have same K.E., which of the two have more momentum and why ?

11. Does the P.E. of a spring decrease or increase when it is compressed or stretched?
12. Name a process in which momentum changes but K.E. does not.
13. What happens to the P.E. of a bubble when it rises in water?
14. A body is moving at constant speed over a frictionless surface. What is the work done by the weight of the body?
15. Define spring constant of a spring.

SHORT ANSWER QUESTIONS (2 MARKS)

16. The momentum of a body is doubled. What % does its K.E. change?
17. Mountain roads rarely go straight up the slope but wind up gradually. Why?
18. A truck and a car moving with the same K.E. on a straight road. Their engines are simultaneously switched off. Which one will stop at a lesser distance?
19. Is it necessary that work done in the motion of a body over a closed loop is zero for every force in nature? Why?
20. Derive an expression for K.E. of a body of mass ' m ' moving with velocity ' v ' by calculus method.
21. How high must a body be lifted to gain an amount of P.E. equal to the K.E. it has when moving at speed 20 ms^{-1} . (The value of acceleration due to gravity at a place is 9.8 ms^{-2}).
22. Give an example in which a force does work on a body but fails to change its K.E.
23. A bob is pulled sideways so that the string becomes parallel to the horizontal and released. Length of the pendulum is 2 m. If due to air resistance the loss of energy is 10%, what is the speed with which the bob arrived at the lowest point?
24. Two springs A and B are identical except that A is harder than B ($K_A > K_B$) if these are stretched by the equal force. In which spring will more work be done?
25. Two springs A and B are identical except that A is harder than B i.e., $K_A > K_B$. In which spring is more work expended if they are stretched by the same amount?
26. Find the work done if a particle moves from position $\vec{r}_1 = (3\hat{i} + 2\hat{j} - 6\hat{k})$ to a position $\vec{r}_2 = (14\hat{i} + 13\hat{j} - 9\hat{k})$ under the effect of force $\vec{F} = (4\hat{i} + \hat{j} + 3\hat{k}) \text{ N}$.

27. A ball at rest is dropped from a height of 12 m. It loses 25% of its kinetic energy in striking the ground, find the height to which it bounces. How do you account for the loss in kinetic energy ?
28. State and prove work energy theorem.
29. Which of the two kilowatt hour or electron volt is a bigger unit of energy and by what factor ?
30. A spring of force constant K is cut into two equal pieces. Calculate force constant of each part.

SHORT ANSWER QUESTIONS (3 MARKS)

31. A elastic spring is compressed by an amount x . Show that its P.E. is $\frac{1}{2} kx^2$ where k is the spring constant.
32. A car of mass 2000 kg is lifted up a distance of 30 m by a crane in 1 min. A second crane does the same job in 2 min. Do the cranes consume the same or different amounts of fuel ? What is the power supplied by each crane ? Neglect Power dissipation against friction.
33. Prove that bodies of identical masses exchange their velocities after head-on elastic collision.
34. A bullet of mass 0.012 kg and horizontal speed 70 m/s strikes a block of wood of mass 0.4 kg and instantly comes to rest w.r.t. the block. The block is suspended from the ceiling by wire. Calculate the height to which the block rises. Also, estimate the amount of heat produced in the block.
35. Define elastic and inelastic collision. A lighter body collides with a much more massive body at rest. Prove that the direction of lighter body is reversed and massive body remains at rest.
36. 20 J work is required to stretch a spring through 0.1 m. Find the force constant of the spring. If the spring is further stretched through 0.1 m. Calculate work done.
37. A body of mass M at rest is struck by a moving body of mass m . Prove that fraction of the initial K.E. of the mass m transferred to the struck body is $\frac{4mM}{(m+M)^2}$ in an elastic collision.

38. A pump on the ground floor of a building can pump up water to fill a tank of volume 30 m^3 in 15 min. If the tank is 40 m above the ground, how much electric power is consumed by the pump. The efficiency of the pump is 30%.
39. Show that in an elastic one dimensional collision the relative velocity of approach before collision is equal to the relative velocity of separation after collision.
40. A ball bounces to 80% of its original height. Calculate the mechanical energy lost in each bounce.

LONG ANSWER QUESTIONS (5 MARKS)

41. Show that at any instant of time during the motion total mechanical energy of a freely falling body remains constant. Show graphically the variation of K.E. and P.E. during the motion.
42. Define spring constant, write the characteristics of the force during the elongation of a spring. Derive the relation for the P.E. stored when it is elongated by X . Draw the graphs to show the variation of P.E. and force with elongation.
43. How does a perfectly inelastic collision differ from perfectly elastic collision ? Two particles of mass m_1 and m_2 having velocities U_1 and U_2 respectively make a head on collision. Derive the relation for their final velocities. Discuss the following special cases.
- (i) $m_1 = m_2$
- (ii) $m_1 \gg m_2$ and $U_2 = 0$
- (iii) $m_1 \ll m_2$ and $U_1 = 0$

NUMERICALS

44. A body is moving along z -axis of a coordinate system under the effect of a constant force $F = (2\hat{i} + 3\hat{j} + \hat{k})\text{N}$. Find the work done by the force in moving the body a distance of 2 m along z -axis.
45. Water is pumped out of a well 10 m deep by means of a pump rated 10 KW. Find the efficiency of the motor if 4200 kg of water is pumped out every minute. Take $g = 10 \text{ m/s}^2$.
46. A railway carriage of mass 9000 kg moving with a speed of 36 km h^{-1} collides with a stationary carriage of same mass. After the collision, the carriages get coupled and move together. What is their common speed after collision ? What type of collision is this ?

47. In lifting a 10 kg weight to a height of 2m, 230 J energy is spent. Calculate the acceleration with which it was raised ?
48. A bullet of mass 0.02 kg is moving with a speed of 10 ms^{-1} . It can penetrate 10 cm of a wooden block, and comes to rest. If the thickness of the target would be 6 cm only, find the K.E. of the bullet when it comes out.
49. A man pulls a lawn roller through a distance of 20 m with a force of 20 kg weight. If he applies the force at an angle of 60° with the ground, calculate the power developed if he takes 1 min in doing so.
50. A body of mass 0.3 kg is taken up an inclined plane to length 10 m and height 5 m and then allowed to slide down to the bottom again. The coefficient of friction between the body and the plane is 0.15. What is the
- work done by the gravitational force over the round trip.
 - work done by the applied force over the upward journey.
 - work done by frictional force over the round trip.
 - kinetic energy of the body at the end of the trip.

How is the answer to (iv) related to the first three answer ?

51. Two identical 5 kg blocks are moving with same speed of 2 ms^{-1} towards each other along a frictionless horizontal surface. The two blocks collide, stick together and come to rest. Consider the two blocks as a system. Calculate work done by (i) external forces and (i) Internal forces.
52. A truck of mass 1000 kg accelerates uniformly from rest to a velocity of 15 ms^{-1} in 5 seconds. Calculate (i) its acceleration, (ii) its gain in K.E., (iii) average power of the engine during this period, neglect friction.
53. An elevator which can carry a maximum load of 1800 kg (elevator + passengers) is moving up with a constant speed of 2 ms^{-1} . The frictional force opposing the motion is 4000 N. Determine the minimum power delivered by the motor to the elevator in watts as well as in horse power.
54. To simulate car accidents, auto manufacturers study the collisions of moving cars with mounted springs of different spring constants. Consider a typical simulation with a car of mass 1000 kg moving with a speed 18.0 kmh^{-1} on a smooth road and colliding with a horizontally mounted spring of spring constant $6.25 \times 10^3 \text{ Nm}^{-1}$. What is the maximum compression of the spring.

MCQ (Work, Energy and Power)

55. A man is squatting on the ground gets straight up and stand. The force of reaction of ground on the man during the process is
- (a) constant and equal to 'mg' in magnitude.
 - (b) constant and greater than 'mg' in magnitude.
 - (c) variable but always greater than 'mg'
 - (d) at first greater than 'mg' and later becomes equal to 'mg'
56. A body of mass 0.5 kg travels in straight line with velocity $V = ax^{3/2}$ where $a = 5 \text{ m}^{-1/2} \text{ s}^{-1}$. The work done by the net force during it's displacement from $x = 0$ to $x = 2\text{m}$ is
- (a) 15 J
 - (b) 50 J
 - (c) 10 J
 - (d) 100 j
57. A mass of 5 kg is moving along a circular path of radius 1 m. If the mass moves with 300 rev/min. it's kinetic energy would be
- (a) $250 \pi^2$
 - (b) $100 \pi^2$
 - (c) $5 \pi^2$
 - (d) 0
58. An Athlete in the Olympic games covers a distance of 100 m in 10s, this kinetic energy can be estimated to be in the range (assume $m = 60 \text{ kg}$)
- (a) 200J – 500 J
 - (b) $2 \times 10^5 \text{J} - 3 \times 10^5 \text{J}$
 - (c) 20000J – 50000J
 - (d) 2000J – 5000J
59. A block of mass 0.5 kg is moving with a speed of 2m/s on a smooth surface. It strikes another mass of 1 kg at rest and then they move together as a single body. The energy loss during the collision is
- (a) 0.16J
 - (b) 1.00 J
 - (c) 0.67 J
 - (d) 0.34J
60. A bullet fired in to a fixed target losses half of it's velocity after penetrating distance of 3 cm. How much further it will penetrate before coming to rest assuming that it faces constant resistance to it's motion?
- (a) 3 cm
 - (b) 2.0 cm
 - (c) 1.5 cm
 - (d) 1.0 cm

61. A uniform chain of length 2m is kept on a table such that a length of 60 cm hangs freely from the edge of the table. The total mass of the chain is 4 kg. What is the work done in pulling the entire chain on the table?
- (a) 7.2 J (b) 3.6 J
(c) 120 J (d) 1200 J
62. If the linear momentum is increased by 50%, then kinetic energy will increase by
- (a) 50% (b) 100%
(c) 125% (d) 25%
63. A block having mass 'm' collides with another stationary block having mass 2m. The lighter block comes to rest after collision. If the velocity of first block is V, then the value of co-efficient of restitution will be
- (a) 0.5 (b) 0.4
(c) 0.6 (d) 0.8
64. A body of mass 50 kg is at rest. The work done to accelerate it by 20 m/s in 10 s is
- (a) 10^3 J (b) 10^4 J
(c) 2×10^3 J (d) 4×10^4 J
65. A spring of force constant 800 Nm^{-1} has an extension of 5 cm. The work done in extending it from 5 cm to 15 cm is
- (a) 16 J (b) 8 J
(c) 35 J (d) 24 J
66. A particle is projected at an angle of 60° to the horizontal with a kinetic energy E. The kinetic energy at the highest point is
- (a) E (b) E/4
(c) E/2 (d) Zero
67. A child is sitting on a swing. Its minimum and maximum heights from the ground 0.75 m and 2 m respectively, it's maximum speed will be
- (a) 10 m s^{-1} (b) 5 m s^{-1}
(c) 8 m/s (d) 15 m s^{-1}

68. 300 J of work is done in sliding a 2 kg block up on inclined plane of height 10 m. Work done against friction is ($g = 10 \text{ ms}^{-2}$)
- (a) 1000 J (b) 200 J
(c) 100 J (d) Zero
69. During inelastic collision between two bodies, which of the following quantities always remain conserved
- (a) Total kinetic energy (b) Total mechanical energy
(c) Total linear momentum (d) Speed of each body
70. Two bodies with kinetic energies in the ratio 4 : 1 are moving with equal linear momentum. The ratio of their masses is
- (a) 4 : 1 (b) 1 : 1
(c) 1 : 2 (d) 1 : 4
71. A position dependent force, $F = 7 - 2x + 3x^2 \text{ N}$ acts on a small body of mass 2 kg and displaces it from $x = 0$ to $x = 5 \text{ m}$. The work done in joule is
- (a) 135 (b) 270
(c) 35 (d) 70
72. A ball is dropped from height 'h' on the ground where co-efficient of restitution is 'e'. After one bounce the maximum height is
- (a) $e^2 h$ (b) $e\sqrt{h}$
(c) eh (d) \sqrt{eh}
73. How much water a pump of 2 KW can raise in one minute to a height of 10 m? ($g = 10 \text{ ms}$)?
- (a) 1000 litres (b) 1200 litres
(c) 10 litres (d) 2000 litres
74. A bomb of mass 30 kg at rest explodes in to two pieces of masses 18 kg and 12 kg. The velocity of 18 kg mass is 6 ms^{-1} . The kinetic energy of the other mass is
- (a) 324 J (b) 486 J
(c) 256 J (d) 5245 J

ASSERTION AND REASON TYPE QUESTIONS

(Work, Power and Energy)

Directions:- The following questions consist of two statements each, labelled as Assertion (A) and the other labelled Reason (R). While answering these questions. You are required to choose any of the following four options (a), (b), (c) & (d).

- (a) If both A and R are true and R is the correct explanation of A.
(b) If both A and R are true but R is NOT the correct explanation of A.
(c) If A is true but R is false.
(d) If A is false and R is also false/True.
1. Assertion (A) : When two equal masses undergo a glancing elastic collision in 2D with one of them at rest, then after the collision, they will be at 90° to each other.
Reason (R) : It follows from the principle of conservation of linear momentum.
2. Assertion (A) : According to law of conservation of mechanical energy, change in potential energy is equal to and opposite for the change kinetic energy.
Reason (R) : Mechanical energy is not a conserved quantity.
3. Assertion (A) : Friction is a non-conservative force.
Reason (R) : This is because work done against friction in moving a body over a curved path is never zero.
4. Assertion (A) : Mass and energy are not conserved separately, but are conserved as a single entity called mass-energy.
Reason (R) : This is because one can be obtained at the cost of the other as per Einstein equation ($E = mc^2$).
5. Assertion (A) : Work done by the centripetal force in moving a body along a circle is always zero.
Reason (R) : Because displacement of the body is along the force.
6. Assertion (A) : A spring has potential energy, both when it is compressed or stretched.
Reason (R) : This is because in compressing or stretching work is done by the spring against the restoring force.

7. Assertion (A) : Graph between potential energy of a spring v/s the extension / compression (x) of the spring is a straight line.
Reason (R) : Potential energy is directly proportional to x .
8. Assertion (A) : In an elastic collision between the two bodies, the relative speed of the bodies after collisions is equal to the relative speed before the collision.
Reason (R) : In a elastic collision the linear momentum of the system is conserved.
9. Assertion (A) : Work done by the frictional force is negative.
Reason (R) : Frictional force acts along the direction of motion.
10. Assertion (A) : A body cannot have energy without possessing momentum but it can have momentum without having energy.
Reason (R) : Momentum and energy have same dimensions.
11. Assertion (A) : Time taken by a body to complete a given work has nothing to do with energy of the body.
Reason (R) : Power of a body is the rate of doing work.
12. Assertion (A) : Two particles moving in the same direction do not lose all their energy in a perfectly inelastic collision.
Reason (R) : Principle of conservation of linear momentum holds true for all kind of collisions.

CASE STUDY BASED QUESTIONS

Work :-

- Q1.** The term work is frequently used in everybody language. A farmer ploughing the field, a construction worker carrying bricks on his head, a student studying for a competitive examination, an artist painting a beautiful landscape. All are said to be working but in the language of physics they are not doing any work! In physics however the word 'Work' covers a definite & precise meaning. Energy is capacity of a body to do the work & power is the rate of doing work.

Though work is scalar quantity, yet its value may positive, negative and Zero.

- (i) In physics work is defined as -
- Product of component of force in the direction of displacement and the magnitude of displacement.
 - Product of component of force perpendicular to the direction of displacement and its magnitude of the displacement.
 - Cross product of force vector and displacement vector.
 - Product of the component of the force in the direction of displacement and magnitude of velocity.
- (ii) Which of the following is not an example of zero work done -
- Work done by centripetal force.
 - Work done by tension in a spring of simple pendulum.
 - Word done by a frictional force.
 - The work done in pushing a immovable stone.
- (iii) A body is subjected to a constant force.
- $$\vec{F} = -\hat{i} + 2\hat{j} + 3\hat{k} \text{ (N)}$$
- is constrained to move along the z axis of a coordinate system. The work done by the force in moving the body though a distance of 4m along z axis is
- 12 J
 - 12 J
 - 0 J
 - 16 J
- (iv) When a body is thrown up, during the upward journey the work done by gravity an the body is
- + Positive
 - Zero
 - negative
 - cannot say
- (v) A body is initially at rest. It undergoes one-dimensional motion with constant acceleration. The power delivered to it at time t is proportional to
- $t^{1/2}$
 - t
 - $t^{3/2}$
 - t^2

Conservative Forces & Non-conservative Forces, Transformation & Conservation of energy :-

- Q2.** The process of changing or converting one form of energy into another form is known as transformation of energy. We know, mechanical energy of a system is conserved, if forces acting on it are conservative forces. However, if a system is acted upon by conservative & non-conservative forces, then some of the mechanical energy of the system is converted

into other forms of energy like sound, heat & light energies but total mechanical energy of the system remains constant. Mechanical energy is the sum of kinetic energy & potential energy where $K.E = \frac{1}{2}mv^2$ and potential energy = mgh , where symbols have usual meanings.

- (i) Which one the following is non-conservative force?
 (a) gravitational force (b) electrostatic force
 (c) magnetic force (d) frictional force
- (ii) A body falling freely under the action of gravity alone in vacuum. Which of the following quantities remains constant during the fall :-
 (a) kinetic energy
 (b) potential energy
 (c) total mechanical energy
 (d) total linear momentum
- (iii) A mass of 5 kg is moving along a circular path of radius 1 m. If mass moves with 300 rev./min., its KE would be
 (a) $250 \pi^2 J$ (b) $100 \pi^2 J$ (c) $5 \pi^2 J$ (d) 0 J
- (iv) In which case the potential energy decreases ?
 (a) on compressing the string
 (b) on stretching the string
 (c) on moving a body against gravitational pull
 (d) on rising of an air bubble in water
- (v) The bob of simple pendulum is held in the horizontal position A. Assuming no loss of energy, speed of bob at the lowest position B when released is

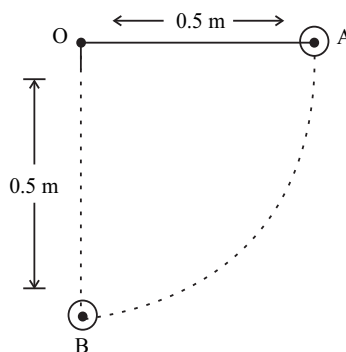

- (a) $\sqrt{9.8}$ m/s
 (b) 9.8 m/s
 (c) 0 m/s
 (d) $\sqrt{2 \times 9.8}$ m/s

Motion in a Vertical Circle :-

Q3. A uniform circular motion is the motion of a particle travelling at a constant (uniform) speed along circular path and hence its kinetic energy remain same everywhere. But when a particle moves in a vertical circle completing the loop, then its speed goes on changing at every point & hence, its kinetic energy goes on changing but total mechanical energy remains constant.

- (i) Uniform circular motion is an example of
- (a) accelerated motion
 - (b) uniform motion
 - (c) non-accelerated motion
 - (d) None of the above
- (ii) The minimum velocity with which a body of mass m must enter a vertical loop of radius r , so that it can complete the loop is
- (a) $\sqrt{2gr}$
 - (b) $\sqrt{3gr}$
 - (c) \sqrt{gr}
 - (d) $\sqrt{5gr}$
- (iii) A bucket of water of mass m is rotated in a vertical circle of radius r such that the bucket is upside down at the highest point. The minimum angular velocity so that the water does not spill out is
- (a) $\omega = \sqrt{\frac{r}{g}}$
 - (b) $\omega = \sqrt{\frac{g}{r}}$
 - (c) $\omega = \sqrt{rg}$
 - (d) $\omega = \sqrt{3rg}$
- (iv) Particle of mass m executing a circular motion in a vertical plane (of radius r) has the tension in the string at the lowest point equal to
- (a) $T_L = mg$
 - (b) $T_L = 0$
 - (c) $T_L = \frac{mv_L^2}{r} + mg$
 - (d) $T_L = \frac{mv_L^2}{r} - mg$
- (v) The ratio of kinetic energy at the lowest point to the kinetic energy of the highest point of a vertical circle of radius r looping by a particle of mass m is
- (a) 1 : 5
 - (b) 1 : 3
 - (c) 3 : 1
 - (d) 5 : 1

Collision :-

Q4. The laws of momentum & energy conservation are successfully applied to a commonly encountered phenomenon; namely – collisions. Several

games such as billiards, marble or carom involve collisions. In all types of collisions; the linear momentum is conserved, on the other hand the total kinetic energy of the system is not necessarily conserved. The impact & deformation during collision may generate heat & sound.

The degree of elasticity of a collision is determined by a quantity called coefficient of restitution (e).

- (i) In an elastic collision
- (a) both momentum & kinetic energy are conserved
 - (b) both momentum & kinetic energy are non-conserved
 - (c) only energy is conserved
 - (d) Only momentum is conserved.
- (ii) A body of mass M_1 collides elastically with another man M_2 at rest. There is 100% transfer of energy takes place when (assuming perfectly elastic collision)
- (a) $M_1 > M_2$
 - (b) $M_1 < M_2$
 - (c) $M_1 = M_2$
 - (d) Same of all values of M_1 & M_2
- (iii) A bullet hits and gets embedded in a solid block resting on a frictionless surface. In this process which one of the following is correct?
- (a) only momentum is conserved
 - (b) only KE is conserved
 - (c) Neither momentum nor KE is conserved
 - (d) Both momentum & KE are conserved.
- (iv) Two identical balls A & B collide head on elastically of velocities of A & B, before the collision are +0.5 m/s and -0.3 m/s respectively, then their velocities after the collision are respectively -
- (a) -0.5 m/s, +0.3 m/s
 - (b) +0.5 m/s, +0.3 m/s
 - (c) +0.3 m/s, -0.5 m/s
 - (d) -0.3 m/s, +0.5 m/s
- (v) Two bodies of mass 0.25 kg each moving towards each other with velocities 3 m/s & 1 m/s respectively. After collision, they stick together. The velocity of the combination will be -
- (a) 0.1 cm/s
 - (b) 1 cm/s
 - (c) 1 m/s
 - (d) cannot be predicted

VERY SHORT ANSWERS (1 MARKS)

1. **Conservative force** : e.g., Gravitational force, electrostatic force.

Non-Conservative force : e.g., forces of friction, viscosity.

2. Lighter body has more K.E. as $K.E. = \frac{p^2}{2m}$ and for constant p , $K.E. \propto \frac{1}{m}$.

3. $W = 0$ as angle between the force and displacement is 90° .

$$\text{and } W = FS \cos \theta = W = 0$$

4. $W = FS \cos 90^\circ = 0$.

5. Hard spring.

6. Inelastic collision.

7. (i) Displacement is zero or it is perpendicular to force.

(ii) Conservative force moves a body over a closed path.

8. Momentum becomes $\sqrt{2}$ times.

9. $K.E. = \frac{p^2}{2m}$ so $p = \sqrt{2mk}$

$$\text{Increase in K.E.} = 300\% \text{ of } k = 3k$$

$$\text{Final K.E., } k' = k + 3k = 4k$$

$$\begin{aligned} \text{Final momentum, } p' &= \sqrt{2mk'} = \sqrt{2m \times 4k} = 2\sqrt{2mk} \\ &= 2p \end{aligned}$$

$$\% \text{ Increase in momentum} = \frac{p' - p}{p} \times 100 = 100\%$$

10. Heavier body; for same kinetic energy $p \propto \sqrt{m}$

11. Increases because W.D. on it when it is compressed or stretched.

12. Uniform circular motion.

13. Decreases.

14. $W = 0$.

15. It is the restoring force set up in a string per unit extension.

SHORT ANSWERS (2 MARKS)

16. $K.E = p^2/2m$ when p is doubled, $K.E$ becomes 4 times.
17. If roads go straight up then angle of slope θ would be large so frictional force $f = \mu mg \cos \theta$ would be less and the vehicles may slip. Also greater power would be required.

18. By Work - Energy Theorem,

$$\begin{aligned} \text{Loss in K.E.} &= \text{W.D. against the force} \times \text{distance of friction} \\ \text{or} & \quad \text{K.E.} = \mu mg S \end{aligned}$$

$$\text{For constant K.E.,} \quad S \propto \frac{1}{m}$$

\therefore Truck will stop in a lesser distance.

19. No. W.D. is zero only in case of a conservative force.

21.
$$mgh = \frac{1}{2}mv^2$$

so
$$h = 20.4 \text{ m}$$

22. When a body is pulled on a rough, horizontal surface with constant velocity. Work is done on the body but $K.E.$ remains unchanged.

23.
$$\frac{1}{2}mv^2 = 90\% \text{ of } mgh$$

$$\therefore v = 6 \text{ m/s}$$

24. $F = Kx$ so $x = \frac{F}{K}$

For same F ,
$$W_A = \frac{1}{2}K_A x^2 = \frac{1}{2} \frac{F^2}{K_A}$$

and
$$W_B = \frac{F^2}{2K_B}$$

$$\therefore \frac{W_A}{W_B} = \frac{K_B}{K_A}$$

As $K_A > K_B$ so $W_A < W_B$.

25. $W = \frac{1}{2}Kx^2$; $\frac{W_A}{W_B} = \frac{K_A}{K_B}$, for some x

As $K_A > K_B$ So $W_A > W_B$

$$26. \vec{r} = \vec{r}_2 - \vec{r}_1 = 11\hat{i} + 11\hat{j} - 3\hat{k}$$

$$\vec{F} = (4\hat{i} + \hat{j} + 3\hat{k}) N$$

$$W = \vec{F} \cdot \vec{r} = 46 J$$

27. If ball bounces to height h' , then

$$mgh' = 75\% \text{ of } mgh$$

$$\therefore h' = 0.75 h = 9 \text{ m.}$$

29. kwh is a bigger unit of energy.

$$\frac{1kwh}{1eV} = \frac{3.6 \times 10^6 J}{1.6 \times 10^{-19} J} = 2.25 \times 10^{25}$$

30. Force constant of each half becomes twice the force constant of the original spring.

SHORT ANSWERS (3 MARKS)

32. $t_1 = 1 \text{ min} = 60 \text{ s}$, $t_2 = 2 \text{ min} = 120 \text{ s}$

$$W = F_s = mgs = 5.88 \times 10^5 J$$

As both cranes do same amount of work so both consume same amount of fuel.

$$P_1 = \frac{W}{t_1}$$

and $P_1 = \frac{W}{t_2}$

$$\therefore P_1 = 9800 \text{ W} \text{ \& } P_2 = 4900 \text{ W.}$$

36. P.E. of spring when stretched through a distance 0.1 m ,

$$U = \text{W.D.}$$

$$= \frac{1}{2} Kx^2 = 20 \text{ J}$$

$$K = 4000 \text{ N/m}$$

when spring is further stretched through 0.1 m , then P.E. will be :

$$U' = \frac{1}{2} k(0.2)^2 = 80 \text{ J}$$

$$\therefore \text{W.D.} = U' - U = 80 - 20 = 60 \text{ J.}$$

$$38. \quad 30\% \text{ of Power} = \frac{W}{t} = \frac{mgh}{t} = \frac{V\rho gh}{t}$$

$$\frac{30}{100} \times P = \frac{V\rho gh}{t}$$

$$\therefore P = 43.6 \text{ KW.}$$

40. Let Initial P.E. = mgh

$$\begin{aligned} \text{P.E. after first bounce} &= mg \times 80\% \text{ of } h \\ &= 0.80 mgh \end{aligned}$$

$$\text{P.E. lost in each bounce} = 0.20 mgh$$

\therefore Fraction of P.E. lost in each bounce

$$= \frac{0.20mgh}{mgh} = 0.20$$

NUMERICAL ANSWERS

$$44. \quad \vec{F} = (2\hat{i} + 3\hat{j} + \hat{k})\text{N}, \vec{S} = 2\hat{k}$$

$$W = \vec{F} \cdot \vec{S} = 2 \text{ J.}$$

45. Input power = 10 KW

$$\text{Output power} = \frac{W}{t} = \frac{mgh}{t} = 7 \text{ KW}$$

$$\therefore \text{Efficiency} = \frac{\text{Output power}}{\text{Input power}} \times 100 = 70\%$$

46. $m_1 = 9000 \text{ kg}, u_1 = 36 \text{ km/h} = 10 \text{ m/s}$

$$m_2 = 9000 \text{ kg}, u_2 = 0, v = v_1 = v_2 = ?$$

By conservation of momentum :

$$m_1u_1 + m_2u_2 = (m_1 + m_2)v$$

$$\therefore v = 5 \text{ m/s}$$

$$\text{Total K.E. before collision} = \frac{1}{2}m_1u_1^2 + \frac{1}{2}m_2u_2^2$$

$$= 45000 \text{ J}$$

$$\text{Total K.E. after collision} = \frac{1}{2}(m_1 + m_2)v^2 = 225000 \text{ J}$$

As total K.E. after collision < Total K.E. before collision

∴ Collision is inelastic.

47. $W = mgh + mah = m(g + a)h$

∴ $a = 1.5 \text{ m/s}^2.$

48. For $x = 10 \text{ cm} = 0.1 \text{ m}$, $Fx = \frac{1}{2}mv_1^2 = 1 \text{ J}$

∴ $F = 10 \text{ N}$

For $x = 6 \text{ cm} = 0.06 \text{ m}$, $Fx = \frac{1}{2}mv_1^2 - \frac{1}{2}mv_2^2$

or $Fx = \frac{1}{2}mv_1^2 - \text{Final K.E.}$

or $\text{Final K.E.} = \frac{1}{2}mv_1^2 - Fx = 1 - 10 \times 0.06$
 $= 1 - 0.6$
 $= 0.4 \text{ J}$

49. $P = \frac{W}{t} = \frac{Fs \cos \theta}{t} = 3266 \text{ W}$

50.

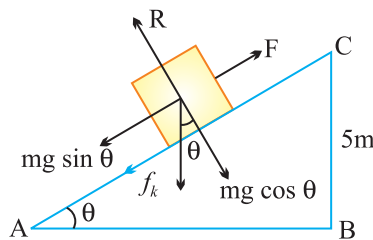

$$\sin \theta = \frac{CB}{CA} = 0.5$$

∴ $\theta = 30^\circ.$

(i) $W = FS = -mg \sin \theta \times h = -14.7 \text{ J}$ is the W.D. by gravitational force in moving the body up the inclined plane.

$W' = FS = +mg \sin \theta \times h = 14.7 \text{ J}$ is the W.D. by gravitational force in moving the body down the inclined plane.

∴ Total W.D. round the trip, $W_1 = W + W' = 0.$

(ii) Force needed to move the body up the inclined plane,

$$\begin{aligned} F &= mg \sin \theta + f_k \\ &= mg \sin \theta + \mu_k R \\ &= mg \sin \theta + \mu_k mg \cos \theta \end{aligned}$$

\therefore W.D. by force over the upward journey is

$$\begin{aligned} W_2 &= F \times l = mg (\sin \theta + \mu_k \cos \theta) l \\ &= 18.5 \text{ J} \end{aligned}$$

(iii) W.D. by frictional force over the round trip,

$$\begin{aligned} W_3 &= -f_k (l + l) = -2f_k l \\ &= -2\mu_k mg \cos \theta l = -7.6 \text{ J} \end{aligned}$$

(iv) K.E. of the body at the end of round trip

= W.D. by net force in moving the body down
the inclined plane

$$\begin{aligned} &= (mg \sin \theta - \mu_k mg \cos \theta) l \\ &= 10.9 \text{ J} \end{aligned}$$

\Rightarrow K.E. of body = net W.D. on the body.

51. Here no external forces are acting on the system so :

$$\vec{F}_{\text{ext.}} = 0 \Rightarrow W_{\text{ext.}} = 0$$

According to work-energy theorem :

$$\text{Total W.D.} = \text{Change in K.E.}$$

or $W_{\text{ext.}} + W_{\text{int.}} = \text{Final K.E.} - \text{Initial K.E.}$

$$0 + W_{\text{int.}} = 0 - \left(\frac{1}{2} mu^2 + \frac{1}{2} mu^2 \right)$$

or $W_{\text{int.}} = -mu^2 = -20 \text{ J}$

52. (i) $a = \frac{v-u}{t} = 3 \text{ m/s}^2$

(ii) Gain in K.E. = $\frac{1}{2}m(v^2 - u^2) = 1.125 \times 10^5 \text{ J}$

(iii) $P = \frac{W}{t} = 22500 \text{ W}$

53. Downward force on the elevator is :

$$F = mg + f = 22000 \text{ N}$$

∴ Power supplied by motor to balance this force is :

$$\begin{aligned} P &= Fv = 44000 \text{ W} \\ &= \frac{44000}{746} = 59 \text{ hp.} \end{aligned}$$

54. At maximum compression x_m , the K.E. of the car is converted entirely into the P.E. of the spring.

$$\therefore \frac{1}{2}kx_m^2 = \frac{1}{2}mv^2$$

or $x_m = 2 \text{ m.}$

Answer Key :

55. (d) 56. (b) 57. (a) 58. (d) 59. (c) 60. (d)
 61. (b) 62. (c) 63. (a) 64. (b) 65. (b) 66. (b)
 67. (b) 68. (c) 69. (c) 70. (d) 71. (a) 72. (a)
 73. (b) 74. (b)

HINTS AND SOLUTION TO MCQ

55. (d) In squatting, he is tilted some what, hence also has to balance frictional force besides his weight in this case $R = \text{friction} + mg$
 $\Rightarrow R > mg$
 When he set straight up in that case,
 $R = mg.$

56. (b)

$$\vec{A} = \frac{d\vec{v}}{dt} = \frac{2}{2} a^2 x^2, \vec{F} = m \vec{A}$$

$$w = \int_0^2 F ds = 50J$$

57. (a) $V = \omega R, \omega = \frac{2\pi}{T} = 10\pi \text{ rad/s}$

$$V = 10\pi \text{ ms}^{-1} \Rightarrow \text{K.E} = \frac{1}{2} mv^2 = 250\pi^2 J$$

58. (d) $V_{av} = \frac{S}{t} = 10\text{ms}^{-1}, m = 60 \text{ kg} \Rightarrow \text{Av. K.E. } 3000J$

59. (c) $m_1 v_1 + m_2 v_2 = (m_1 + m_2)V \Rightarrow v = \frac{2}{3} \text{ms}^{-1}$

$$\text{Energy loss} = \frac{1}{2} \times 0.5 \times 2^2 - \frac{1}{2} \times 1.5 \times \left(\frac{2}{3}\right)^2 = 0.67 J$$

60. (d) $W = \Delta K$

$$\text{Case I: } -F \times 3 = \frac{1}{2} m \left(\frac{V_0}{2}\right)^2 - \frac{1}{2} m V_0^2,$$

Where $F \rightarrow$ resistive force

$V_0 \rightarrow$ initial velocity

Case II : Let further distance be 's'

$$-F(3+s) = K_f - K_i = -\frac{1}{2} m V_0^2$$

$$s = 1 \text{ cm}$$

61. (b) Mass per unit length = $\frac{4 \text{ kg}}{2 \text{ m}} = 2 \text{ kg m}^{-1}$

Mass of 60 cm length = 1.2 kg.

weight of hanging part = $1.2 \times 10 = 12 \text{ N}$

$W = F \times S = 12 \times 0.3 = 3.6 \text{ J}$.

62. (c) $P^1 = 1.5P$, Initial K.E. = $\frac{P^2}{2m}$, Find K.E., $K^1 = \frac{P^{12}}{2m}$

$K^1 = 2.25 K$

% increase = $\frac{\Delta K}{K} \times 100 = 125\%$

63. (a) By conservation of momentum

$mV = 2mV^1 \Rightarrow V^1 = \frac{V}{2}$

$e = \frac{\text{Vel. of separation}}{\text{Velocity of approach}} = 0.5$

64. (b) $a = \frac{v-u}{t} = 2 \text{ ms}^{-2}$, $5 = ut + \frac{1}{2} at^2 = 100 \text{ m}$

$W = F \times S = 10^4 \text{ J}$

65. (b) $W = \frac{1}{2} \times 800 (0.15^2 - 0.05^2) = 8 \text{ J}$.

66. (b) K.E. at highest point = $\frac{1}{2} m (4 \cos 60^\circ)^2 = \frac{E}{4}$.

67. (b) Maximum K.E. = Drop in P.E.

$\frac{1}{2} m V_{\max}^2 = mg (h_2 - h_1) \Rightarrow V_{\max} = 5 \text{ ms}^{-1}$

68. (c) Total work done = Gain in P.E. + Work done against friction
 $300 = 2 \times 10 \times 10 + W \Rightarrow W = 100 \text{ J}$.

70. (d) $E\alpha \frac{1}{m}$ or $m\alpha \frac{1}{E}$
 $\frac{m_1}{m_2} = \frac{E_2}{E_1} = \frac{1}{4}$

71. (a) $W = \int F dx = 135 \text{ J}$

72. (a) Velocity with which the ball strikes the ground, $u = \sqrt{2gh}$

If the ball re-bounces with velocity, V , then $V = eu = e\sqrt{2gh}$

If $h' \rightarrow$ max. height after one bounce, then

$$0^2 - V^2 = 2(-g)h' \Rightarrow h' = e^2 h$$

73. (b) $P = \frac{w}{t} \Rightarrow w = Pt = mgh \Rightarrow m = 1200 \text{ kg}$

74. (b) By conservation of momentum

$$30 \times 0 = 18 \times 6 + 12 + V \rightarrow V = -9 \text{ ms}^{-1}$$

$$\text{K.E.} = \frac{1}{2} mV^2 = 486 \text{ J}$$

ASSERTION - REASON BASED ANSWERS

1. (a) both A & R are true and R is the correct explanation of A.

2. (c) A is true but the R is false.

According to Law of conservation of mechanical on energy (If No external forces do work on a system),

$$K + U = \text{constant}$$

$$\Delta K + \Delta U = 0 \quad \text{or} \quad \Delta K = -\Delta U.$$

3. (a) both A & R are true and R is the correct explanation of assertion.

4. (a) both A & R are true and R is the correct explanation of A.

5. (c) A is true but R is false.

Displacement (tangential) of the body is perpendicular to the centripetal force (acts along radius towards centre).

6. (c) A is true but R is false.
In compressing or stretching the spring, work is done on the spring against the restoring force.
7. (d) both A & R are false.
P.E. of a spring; $U = \frac{1}{2} Kx^2$ [symbols have then usual meaning]
so $U \propto x^2$
so graph is a parabola.
8. (d) Hence Assertion is false, because in elastic collision the relative velocity of separation (not relative speed of separation) is equal to the relative velocity of approach (Not the relative speed of approach) of two bodies during elastic collision.
Reason is though true but cannot explain the assertion.
9. (c) A is true but R is false.
Force of friction acts in the opposite direction of motion.
10. (d) both A & R are false.
A raised body at rest has energy (PE) but no momentum (p) but to possess momentum (p), a body should have KE on $KE = \frac{p^2}{2m}$.
Also dimensions of momentum is $[MLT^{-1}]$ and of energy of $[ML^2T^{-2}]$.
11. (b) both A & R are true but R is not the correct explanation of A.
12. (b) both A & R are true but R is not the correct explanation of A.

CASE STUDY BASED ANSWERS

1. i. (a) $w = fd\cos\theta$
- ii. (c) Work done by a frictional force is an example of negative work done.
- iii. (a) $\vec{F} = -\hat{i} + 2\hat{j} + 3\hat{k}$; $\vec{d} = 4\hat{k}$
 $w = \vec{F} \cdot \vec{d}$
 $= 3\hat{k} \cdot 4\hat{k} = 12\text{J}$
- iv. (c) negative

v. (b) $v = u + at$

$$v = at \text{ as } u = 0$$

$$\text{As power } P = fV = (ma)(at)$$

$$P = Ma^2t \implies p \propto t \text{ as } a \text{ is constant.}$$

2. i. (d)

ii. (c)

iii. (a) $KE = \frac{1}{2} mV^2 = \frac{1}{2} m(rw)^2 = \frac{1}{2} mr^2 4\pi^2 f^2 = 250 \pi^2 \text{ J}$

iv. (d) PE decreases when an air bubble rises in water because work is done by upthrust.

v. (a) Applying Law of Conservation of Energy at A and B.

$$\frac{1}{2} mV^2 = mgh$$

$$v = \sqrt{2gh} = \sqrt{2 \times 9.8 \times 0.5} = \sqrt{9.8} \text{ m/s}$$

3. i. (a) accelerated motion

ii. (d) velocity at the lowest point = $\sqrt{5gr}$

iii. (b) at the highest point $mrw^2 = mg \implies w = \sqrt{\frac{g}{r}}$

iv. (c) $T_L = \frac{mv_L^2}{r} + mg$

v. (d) $\frac{(KE)_L}{(KE)_H} = \frac{v_L^2}{v_H^2} = \frac{5gr}{gr} = \frac{5}{1}$

4. i. (a) both momentum & KE are conserved.

ii. (c) $M_1 = M_2$ [when both the colliding bodies have equal masses, maximum transfer of energy occurs].

iii. (a) only momentum is conserved.

(as this is an example of perfectly inelastic collisions)

iv. (d) $-0.3 \text{ m/s}, +0.5 \text{ m/s}$
(In elastic collision, two identical bodies exchange their velocities after collision)

v. (c) 1 m/s

$$[\text{Common velocity } V = \frac{m_1 u_1 - m_2 u_2}{m_1 + m_2}, u_1 = 3 \text{ m/s}, u_2 = -1 \text{ m/s}]$$

5. i. (a) decreases

ii. (c) 10 m/s

Work done = change in KE

$$\text{Area under } f-x = \frac{1}{2} mv^2 - 0$$

$$\frac{1}{2} (9 + 3) \times 20 = \frac{1}{2} \times 2.4 \times v^2$$

$$\Rightarrow v = 10 \text{ m/s}$$

iii. (a) become twice its initial value [Using $p = \sqrt{2mk}$].

iv. (d) $1 : 4$ [again using $p = \sqrt{2mk} \Rightarrow k = \frac{p^2}{2m}$]

v. (a) -2J [Work done = change in KE = $\frac{1}{2} m(v^2 - u^2) = -2\text{J}$]

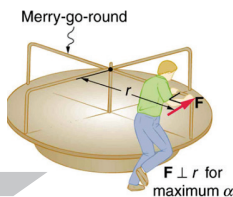

Unit - 5

Rotational Motion

5.1 Introduction

Rigid body : A rigid body is a body that can rotate with all the parts locked together and without any change in its shape.

5.2 Centre of Mass

Centre of mass of a system is a point that moves as though all the mass were concentrated there and all external forces were applied there.

(1) Position vector of centre of mass for n particle system : If a system consists of n particles of masses $m_1, m_2, m_3, \dots, m_n$, whose position vectors are $\vec{r}_1, \vec{r}_2, \vec{r}_3, \dots, \vec{r}_n$ respectively then position vector of centre of mass

$$\vec{r} = \frac{m_1 \vec{r}_1 + m_2 \vec{r}_2 + m_3 \vec{r}_3 + \dots + m_n \vec{r}_n}{m_1 + m_2 + m_3 + \dots + m_n}$$

If two masses are equal *i.e.*, $m_1 = m_2$, then position vector of centre of mass of two particle system is $\vec{r} = \frac{\vec{r}_1 + \vec{r}_2}{2}$.

(2) Important points about centre of mass

- (i) The position of centre of mass is independent of the co-ordinate system chosen.
- (ii) The position of centre of mass depends upon the shape of the body and distribution of mass.
- (iii) In symmetrical bodies in which the distribution of mass is homogeneous, the centre of mass coincides with the geometrical centre or centre of symmetry of the body. Centre of mass of cone

or pyramid lies on the axis of the cone at point distance $\frac{3h}{4}$ from the vertex where h is the height of cone.

(iv) The centre of mass changes its position only under the translatory motion. There is no effect of rotatory motion on centre of mass of the body.

(v) If the origin is at the centre of mass, then the sum of the moments of the masses of the system about the centre of mass is zero *i.e.*,

$$\sum m_i \vec{r}_i = 0$$

(vi) If a system of particles of masses m_1, m_2, m_3, \dots move with velocity v_1, v_2, v_3, \dots then the velocity of centre of mass

$$v_{\text{cm}} = \frac{\sum m_i v_i}{\sum m_i}$$

(vii) If a system of particles of masses m_1, m_2, m_3, \dots move with accelerations a_1, a_2, a_3, \dots then the acceleration of centre of mass

$$A_{\text{cm}} = \frac{\sum m_i a_i}{\sum m_i}$$

(viii) If \vec{r} is a position vector of centre of mass of a system then velocity

$$\text{of centre of mass } \vec{v}_{\text{cm}} = \frac{d\vec{r}}{dt}$$

(ix) Acceleration of centre of mass $\vec{A}_{\text{cm}} = \frac{d\vec{v}_{\text{cm}}}{dt} = \frac{d^2\vec{r}}{dt^2}$.

(x) Force on a rigid body $\vec{F} = M\vec{A}_{\text{cm}} = M\frac{d^2\vec{r}}{dt^2}$.

(xi) For an isolated system external force on the body is zero

$$\vec{F} = M\frac{d}{dt}(\vec{v}_{\text{cm}}) = 0$$

$$\Rightarrow \vec{v}_{\text{cm}} = \text{constant.}$$

i.e., centre of mass of an isolated system moves with uniform velocity along a straight-line path.

5.3 Equations of Linear Motion and Rotational Motion

Rotational Motion

If angular acceleration is 0, $\omega = \text{constant}$ and $\theta = \omega t$

If angular acceleration $\alpha = \text{constant}$ then

$$(i) \quad \theta = \frac{(\omega_1 + \omega_2)}{2} t$$

$$(ii) \quad \alpha = \frac{\omega_2 - \omega_1}{t}$$

$$(iii) \quad \omega_2 = \omega_1 + \alpha t$$

$$(iv) \quad \theta = \omega_1 t + \frac{1}{2} \alpha t^2$$

$$(v) \quad \omega_2^2 = \omega_1^2 + 2\alpha\theta$$

$$(vi) \quad \theta_{nth} = \omega_1 + (2n - 1) \frac{\alpha}{2}$$

If acceleration is not constant, the above equation will not be applicable. In this case

$$(i) \quad \omega = \frac{d\theta}{dt}$$

$$(ii) \quad \alpha = \frac{d\omega}{dt} = \frac{d^2\theta}{dt^2}$$

$$(iii) \quad \omega d\omega = \alpha d\theta$$

5.4 Moment of Inertia

Moment of inertia plays the same role in rotational motion as mass plays in linear motion. It is the property of a body due to which it opposes any change in its state of rest or of uniform rotation.

- (1) Moment of inertia of a particle $I = mr^2$; where r is the perpendicular distance of particle from rotational axis.
- (2) Moment of inertia of a body made up of number of particles (discrete distribution)

$$I = m_1 r_1^2 + m_2 r_2^2 + m_3 r_3^2 + \dots$$

- (3) Moment of inertia of a continuous distribution of mass, $dI = dm r^2$ i.e.,

$$I = \int r^2 dm$$

- (4) Dimension : $[ML^2T^0]$

- (5) S.I. unit : kgm^2 .
- (6) Moment of inertia depends on mass, distribution of mass and on the position of axis of rotation.
- (7) Moment of inertia is a tensor quantity.

5.5 Radius of Gyration

Radius of gyration of a body about a given axis is the perpendicular distance of a point from the axis, where if whole mass of the body were concentrated, the body shall have the same moment of inertia as it has with the actual distribution of mass.

When square of radius of gyration is multiplied with the mass of the body gives the moment of inertia of the body about the given axis.

$$I = Mk^2 \text{ or } k = \sqrt{\frac{I}{M}}$$

Here k is called radius of gyration.

$$k = \sqrt{\frac{r_1^2 + r_2^2 + r_3^2 + \dots + r_n^2}{n}}$$

Note :

- For a given body inertia is constant whereas moment of inertia is variable.

5.6 Theorem of Parallel Axes

Moment of inertia of a body about a given axis I is equal to the sum of moment of inertia of the body about an axis parallel to given axis and passing through centre of mass of the body I_g and Ma^2 where M is the mass of the body and a is the perpendicular distance between the two axes.

$$I = I_g + Ma^2$$

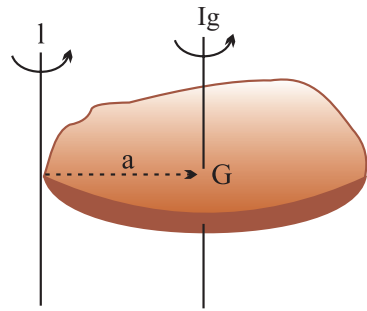

5.7 Theorem of Perpendicular Axes

According to this theorem the sum of moment of inertia of a plane lamina about two mutually perpendicular axes lying in its plane is equal to its moment of inertia about an axis perpendicular to the plane of lamina and passing through the point of intersection of first two axis.

$$I_z = I_x + I_y$$

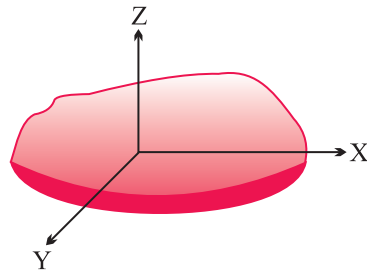

Note :

- In case of symmetrical two-dimensional bodies as moment of inertia for all axes passing through the centre of mass and in the plane of body will be same so the two axes in the plane of body need not be perpendicular to each other.



5.8 Analogy between Translatory Motion and Rotational Motion

Translatory motion		Rotatory motion	
Mass	(m)	Moment of Inertia	(I)
Linear	$P = mv$	Angular	$L = I\omega$
Momentum	$P = \sqrt{2mE}$	Momentum	$L = \sqrt{2IE}$
Force	$F = ma$	Torque	$\tau = I\alpha$
Kinetic energy	$E = \frac{1}{2}mv^2$		$E = \frac{1}{2}I\omega^2$
	$E = \frac{P^2}{2m}$		$E = \frac{L^2}{2I}$

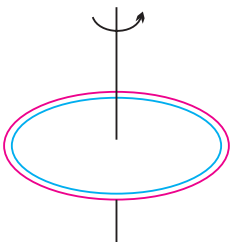
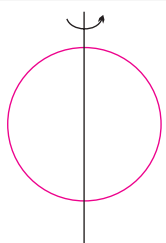
5.9 Moment of Inertia of Some Standard Bodies and Different Axes

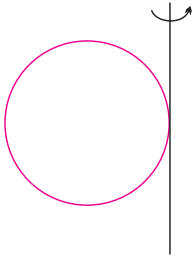
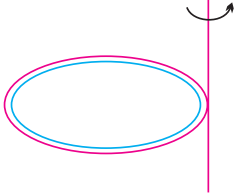
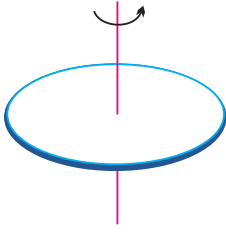
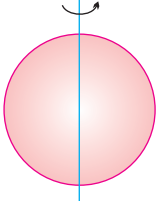
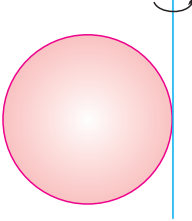
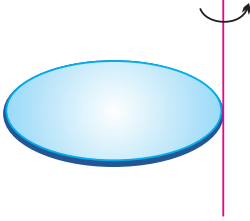
Body	Axis of Rotation	Figure	Moment of inertia	K	K^2/R^2
Ring (Cylindrical Shell)	About an axis Passing through C.G. and perpendicular to its plane		MR^2	R	1
Ring	About its diameter		$\frac{1}{2}MR^2$	$\frac{R}{\sqrt{2}}$	$\frac{1}{2}$

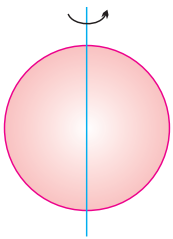
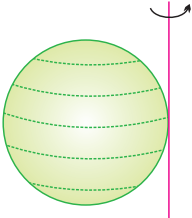
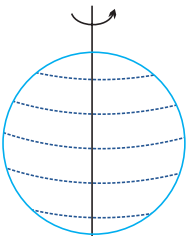
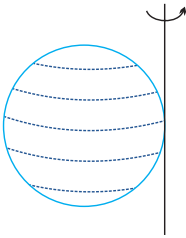
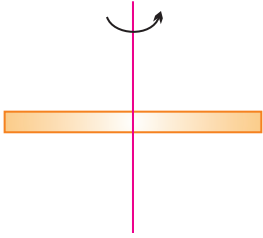
Body	Axis of Rotation	Figure	Moment of inertia	K	K^2/R^2
Ring	About a tangential axis in its own plane		$\frac{3}{2}MR^2$	$\sqrt{\frac{3}{2}}R$	$\frac{3}{2}$
Ring	About a tangential axis perpendicular to its own plane		$2MR^2$	$\sqrt{2}R$	2
Disc (Solid cylinder)	About an axis Passing through C.G. and perpendicular to its plane		$\frac{1}{2}MR^2$	$\frac{R}{\sqrt{2}}$	$\frac{1}{2}$
Disc	About its diameter		$\frac{1}{4}MR^2$	$\frac{R}{2}$	$\frac{1}{4}$
Disc	About a tangential axis in its own plane		$\frac{5}{4}MR^2$	$\frac{\sqrt{5}}{2}R$	$\frac{5}{4}$
Disc	About a tangential axis perpendicular to its own plane		$\frac{3}{2}MR^2$	$\sqrt{\frac{3}{2}}R$	$\frac{3}{2}$

Body	Axis of Rotation	Figure	Moment of inertia	K	K^2/R^2
Solid Sphere	About its diametric axis		$\frac{2}{5}MR^2$	$\sqrt{\frac{2}{5}}R$	$\frac{2}{5}$
Solid Sphere	About a tangential axis		$\frac{7}{5}MR^2$	$\sqrt{\frac{7}{5}}R$	$\frac{7}{5}$
Spherical Shell	About its diametric axis		$\frac{2}{3}MR^2$	$\sqrt{\frac{2}{3}}R$	$\frac{2}{3}$
Spherical Shell	About a tangential axis		$\frac{5}{3}MR^2$	$\sqrt{\frac{5}{3}}R$	$\frac{5}{3}$
Long thin rod	About an axis passing through its centre of mass and perpendicular to the rod		$\frac{ML^2}{12}$	$\frac{L}{\sqrt{12}}$	
Long thin rod	About an axis passing through its edge and perpendicular to the rod		$\frac{ML^2}{3}$	$\frac{L}{\sqrt{3}}$	

5.10 Torque

If the particle rotating in xy plane about the origin under the effect of force \vec{F} and at any instant the position vector of the particle is \vec{r} then,

$$\text{Torque } \vec{\tau} = \vec{r} \times \vec{F}$$

$$\tau = rF \sin \phi$$

[where ϕ is the angle between the direction of \vec{r} and \vec{F}]

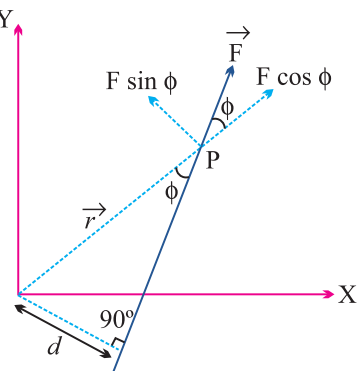

- (1) Torque is an axial vector *i.e.*, its direction is always perpendicular to the plane containing vector \vec{r} and \vec{F} in accordance with right hand screw rule. For a given figure the sense of rotation is anti-clockwise so the direction of torque is perpendicular to the plane, outward through the axis of rotation.

i.e., Torque = Force \times Perpendicular distance of line of action of force from the axis of rotation.

Torque is also called as moment of force and d is called moment or lever arm.

- (2) Unit : Newton-metre (M.K.S.) and Dyne-cm (C.G.S.)
- (3) Dimension : $[ML^2T^{-2}]$.
- (4) A body is said to be in rotational equilibrium if resultant torque acting on it is zero *i.e.*, $\sum \vec{\tau} = 0$.
- (5) Torque is the cause of rotatory motion and in rotational motion it plays same role as force plays in translatory motion *i.e.*, torque is rotational analogue of force. This all is evident from the following correspondences between rotatory and translatory motion.

Rotatory Motion	Translatory Motion
$\vec{\tau} = I \vec{\alpha}$	$\vec{F} = m \vec{a}$
$W = \int \vec{\tau} \cdot d\vec{\theta}$	$W = \int \vec{F} \cdot d\vec{s}$
$P = \vec{\tau} \cdot \vec{\omega}$	$P = \vec{F} \cdot \vec{V}$
$\vec{\tau} = \frac{d\vec{L}}{dt}$	$\vec{F} = \frac{d\vec{P}}{dt}$

5.11 Couple

A couple is defined as combination of two equal but oppositely directed force not acting along the same line. The effect of couple is known by its moment of couple or torque by a couple $\vec{\tau} = r \times \vec{F}$.

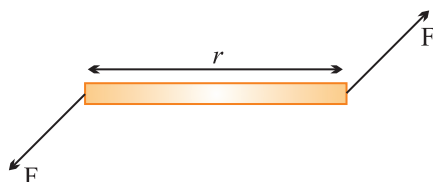

5.12 Angular Momentum

The moment of linear momentum of a body with respect to any axis of rotation is known as angular momentum. If \vec{P} is the linear momentum of particle and \vec{r} its position vector from the point of rotation then angular momentum.

$$\vec{L} = \vec{r} \times \vec{P}$$

$$\vec{L} = rP \sin \phi \hat{n}$$

Angular momentum is an axial vector *i.e.*, always directed perpendicular to the plane of rotation and along the axis of rotation.

- (1) S.I. Unit : $\text{kgm}^2 \text{s}^{-1}$ or J-sec.
- (2) Dimension : $[\text{ML}^2\text{T}^{-2}]$ and it is similar to Planck's constant (h).
- (3) Angular momentum = (Linear momentum) \times (Perpendicular distance of line of action of force from the axis of rotation)

(4) In vector form $\vec{L} = I\vec{\omega}$.

(5) From $\vec{L} = I\vec{\omega}$, $\therefore \frac{d\vec{L}}{dt} = I \frac{d\vec{\omega}}{dt} = I\vec{\alpha} = \vec{\tau}$

[Rotational analogue of Newton's second law]

(6) If a large torque acts on a particle for a small time then 'angular impulse'

of torque is given by $\vec{J} = \int \vec{\tau} dt = \vec{\tau}_{av} \int_{t_1}^{t_2} dt$

\therefore Angular impulse = Change in angular momentum

5.13 Law of Conservation of Angular Momentum

If the net external torque on a particle (or system) is zero then $\frac{d\vec{L}}{dt} = 0$
i.e.,

$$\vec{L} = \vec{L}_1 + \vec{L}_2 + \vec{L}_3 + \dots = \text{constant.}$$

Angular momentum of a system (may be particle or body) remains constant if resultant torque acting on it zero.

As $L = I\omega$ so if $\vec{\tau} = 0$ then $I\omega = \text{constant}$.

5.14 Slipping, Spinning and Rolling

(1) **Slipping** : When the body slides on a surface without rotation then its motion is called slipping motion.

In this condition friction between the body and surface $F = 0$.

Body possess only translatory kinetic energy $K_T = \frac{1}{2}mv^2$.

(2) **Spinning** : When the body rotates in such a manner that its axis of rotation does not move then its motion is called spinning motion. In this condition axis of rotation of a body is fixed.

In spinning, body possess only rotatory kinetic energy $K_R = \frac{1}{2}I\omega^2$.

(3) **Rolling** : If in case of rotational motion of a body about a fixed axis, the axis of rotation also moves, the motion is called combined translatory and rotatory.

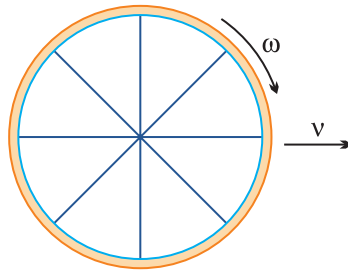

Example :

- (i) Motion of a wheel of cycle on a road.
- (ii) Motion of football rolling on a surface.

In this condition friction between the body and surface $F \neq 0$. Body possesses both translational and rotational kinetic energy.

Net kinetic energy = (Translatory + Rotatory) kinetic energy.

5.15 Rolling Without Slipping

In case of combined translatory and rotatory motion if the object rolls across a surface in such a way that there is no relative motion of object and surface at the point of contact, the motion is called rolling without slipping.

Friction is responsible for this type of motion but work done or dissipation of energy against friction is zero as there is no relative motion between body and surface at the point of contact.

Rolling motion of a body may be treated as a pure rotation about an axis through point of contact with same angular velocity ω . [$v = R\omega$]

Linear velocity of different points in rolling : In case of rolling, all points of a rigid body have same angular speed but different linear speed. Let A, B, C and D are four points then their velocities are shown in the following figure.

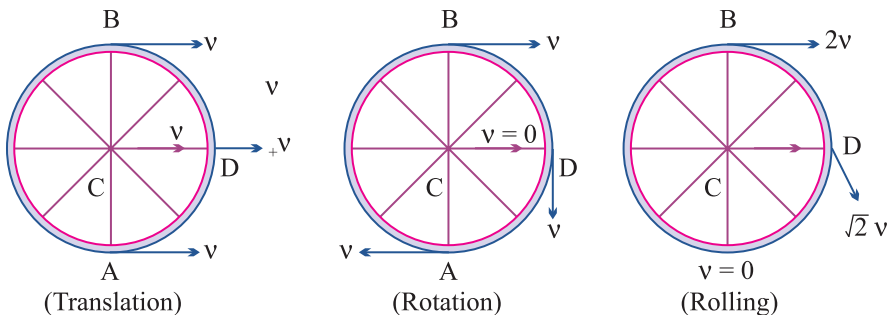

5.16 Rolling on an Inclined Plane

When a body of mass m and radius R rolls down on inclined plane of height ' h ' and angle of inclination θ , it loses potential energy. However it acquires both linear and angular speeds and hence, gain kinetic energy of translation and that of rotation.

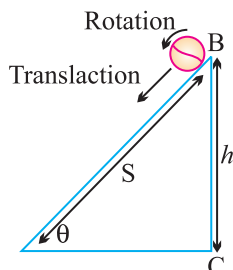

(1) Velocity at the lowest point : $v = \sqrt{\frac{2gh}{1 + \frac{k^2}{R^2}}}$

(2) Acceleration in motion : From equation $v^2 = u^2 + 2as$.

By substituting $u = 0$, $s = \frac{h}{\sin \theta}$ and $v = \sqrt{\frac{2gh}{1 + \frac{k^2}{R^2}}}$, we get $a = \frac{g \sin \theta}{1 + \frac{k^2}{R^2}}$.

(3) Time of descent : From equation $v = u + at$

By substituting $u = 0$ and value of v and a from above expressions

$$t = \frac{1}{\sin \theta} \sqrt{\frac{2h}{g} \left[1 + \frac{k^2}{R^2} \right]}$$

Rotational Motion (1 mark)

1. About which axis a uniform cube will have minimum moment of inertia ?
2. State the principle of moments of rotational equilibrium.
3. Find the moment of inertia of a disc of radius R and mass m about an axis in its plane at a distance $R/2$ from its centre.
4. Can the couple acting on a rigid body produce translator motion ?
5. Which component of linear momentum does not contribute to angular momentum ?
6. A system is in stable equilibrium. What can we say about its potential energy ?
7. Is radius of gyration a constant quantity ?

8. Two solid spheres of the same mass are made of metals of different densities. Which of them has a large moment of inertia about the diameter ?
9. The moment of inertia of two rotating bodies A and B are I_A and I_B ($I_A > I_B$) and their angular momenta are equal. Which one has a greater kinetic energy ?
10. A particle moves on a circular path with decreasing speed. What happens to its angular momentum ?
11. What is the value of instantaneous speed of the point of contact during pure rolling ?
12. Which physical quantity is conserved when a planet revolves around the sun ?
13. What is the value of torque on the planet due to the gravitational force of sun ?
14. If no external torque acts on a body, will its angular velocity be constant ?
15. Why there are two propellers in a helicopter ?
16. A child sits stationary at one end of a long trolley moving uniformly with speed V on a smooth horizontal floor. If the child gets up and runs about on the trolley in any manner, then what is the effect of the speed of the centre of mass of the (trolley + child) system ?

Rotational Motion (2 marks)

17. Show that in the absence of any external force, the velocity of the centre of mass remains constant.
18. State the factors on which the position of centre of mass of a rigid body depends.
19. What is the turning effect of force called for ? On what factors does it depend ?
20. State the factors on which the moment of inertia of a body depends.
21. On what factors does radius of gyration of body depend ?
22. Why the speed of whirl wind in a Tornado is alarmingly high ?
23. Can a body be in equilibrium while in motion ? If yes, give an example.
24. There is a stick half of which is wooden and half is of steel. (i) it is pivoted at the wooden end and a force is applied at the steel end at right angle to its length (ii) it is pivoted at the steel end and the same force is applied at the wooden end. In which case is the angular acceleration more and why ?
25. If earth contracts to half of its present radius what would be the length of the day at equator ?

26. An internal force can not change the state of motion of centre of mass of a body. How does the internal force of the brakes bring a vehicle to rest ?
27. When does a rigid body said to be in equilibrium ? State the necessary condition for a body to be in equilibrium.
28. How will you distinguish between a hard boiled egg and a raw egg by spinning it on a table top ?
29. Equal torques are applied on a cylinder and a sphere. Both have same mass and radius. Cylinder rotates about its axis and sphere rotates about one of its diameter. Which will acquire greater speed and why ?
30. In which condition a body lying in gravitational field is in stable equilibrium ?
31. Give the physical significance of moment of inertia. Explain the need of fly wheel in Engine.

Rotational Motion (3 marks)

32. Derive the three equation of rotational motion

$$(i) \omega = \omega_0 + at \quad (ii) \theta = \omega_0 t + \frac{1}{2} \alpha t^2 \quad (iii) \omega^2 = \omega_0^2 + 2\alpha\theta$$

Under constant angular acceleration. Here symbols have usual meaning.

33. Obtain an expression for the work done by a torque. Hence write the expression for power.
34. Prove that the rate of change of angular momentum of a system of particles about a reference point is equal to the net torque acting on the system.
35. Three mass point m_1, m_2, m_3 are located at the vertices of equilateral Δ of side 'a'. What is the moment of inertia of system about an axis along the altitude of Δ passing through m_1 ?
36. Show that moment of a couple does not depend on the point about which moment is calculated.
37. A disc rotating about its axis with angular speed ω_0 is placed lightly (without any linear push) on a perfectly frictionless table. The radius of the disc is R. What are the linear velocities of the points A, B and C on the disc shown in figure. Will the disc roll ?

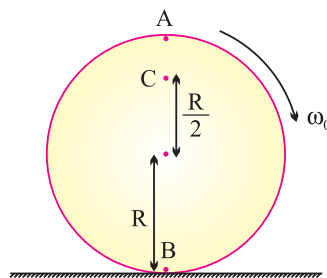

38. A uniform circular disc of radius R is rolling on a horizontal surface. Determine the tangential velocity (i) at the upper most point (ii) at the centre of mass and (iii) at the point of contact.
39. Explain if the ice on the polar caps of the earth melts, how will it affect the duration of the day ?
40. A solid cylinder rolls down an inclined plane. Its mass is 2 kg and radius 0.1 m. If the height of the incline plane is 4 m, what is rotational K.E. when it reaches the foot of the plane ?
41. Find the torque of a force $7i - 3j - 5k$ about the origin which acts on a particle whose position vector is $i + j - k$.

Numericals

42. Three masses 3 kg, 4 kg and 5 kg are located at the corners of an equilateral triangle of side 1 m. Locate the centre of mass of the system.
43. Two particles mass 100 g and 300 g at a given time have velocities $10i - 7j - 3k$ and $7i - 9j + 6k$ ms^{-1} respectively. Determine velocity of COM.
44. From a uniform disc of radius R , a circular disc of radius $R/2$ is cut out. The centre of the hole is at $R/2$ from the centre of original disc. Locate the centre of gravity of the resultant flat body.
45. The angular speed of a motor wheel is increased from 1200 rpm to 3120 rpm in 16 seconds, (i) What is its angular acceleration (assume the acceleration to be uniform) (ii) How many revolutions does the wheel make during this time ?
46. A metre stick is balanced on a knife edge at its centre. When two coins, each of mass 5 g are put one on top of the other at the 12.0 cm mark, the stick is found to be balanced at 45.0 cm, what is the mass of the meter stick ?
47. A solid sphere is rolling on a frictionless plane surface about its axis of symmetry. Find ratio of its rotational energy to its total energy.
48. Calculate the ratio of radii of gyration of a circular ring and a disc of the same radius with respect to the axis passing through their centres and perpendicular to their planes.
49. Two discs of moments of inertia I_1 and I_2 about their respective axes (normal to the disc and passing through the centre), and rotating with angular speed ω_1 and ω_2 are brought into contact face to face with their axes of rotation coincident, (i) What is the angular speed of the two-disc system ? (ii) Show

that the kinetic energy of the combined system is less than the sum of the initial kinetic energies of the two discs. How do you account for this loss in energy? Take $\omega_1 \neq \omega_2$.

50. In the HCl molecule, the separating between the nuclei of the two atoms is about 1.27 Å ($1\text{Å} = 10^{-10}\text{ m}$). Find the approximate location of the CM of the molecule, given that the chlorine atom is about 35.5 times as massive as a hydrogen atom and nearly all the mass of an atom is concentrated in all its nucleus.
51. A child stands at the centre of turn table with his two arms out stretched. The turn table is set rotating with an angular speed of 40 rpm. How much is the angular speed of the child if he folds his hands back and thereby reduces his moment of inertia to $\frac{2}{3}$ times the initial value? Assume that the turn table rotates without friction. (ii) Show that the child's new kinetic energy of rotation is more than the initial kinetic energy of rotation.

How do you account for this increase in kinetic energy?

52. To maintain a rotor at a uniform angular speed of 200 rad s^{-1} , an engine needs to transmit a torque of 180 Nm. What is the power required by the engine? Assume that the engine is 100% efficient.
53. A car weighs 1800 kg. The distance between its front and back axles is 1.8 m. Its centre of gravity is 1.05 m behind the front axle. Determine the force exerted by the level ground on each front and back wheel.

Rotational Motion (5 marks)

54. Prove that the angular momentum of a particle is twice the product of its mass and areal velocity. How does it lead to the Kepler's second law of planetary motion?
55. Prove the result that the velocity V of translation of a rolling body (like a ring, disc, cylinder or sphere) at the bottom of an inclined plane of a height

$$h \text{ is given by } v^2 = \frac{2gh}{1 + \frac{k^2}{R^2}}$$

where K = Radius of gyration of body about its symmetry axis, and R is radius of body. The body starts from rest at the top of the plane.

56. (i) Establish the relation between torque and angular acceleration.

Hence define moment of inertia.

62. Distance of the centre of mass of a solid uniform cone from its vertex is Z_0 . If the radius of its base is R and its height is h , the Z_0 is equal to
- (a) $\frac{h^2}{4R}$ (b) $\frac{3h}{4}$
(c) $\frac{5h}{8}$ (d) $\frac{3h^2}{8R}$
63. Angular momentum of the particle rotating with a central force is constant due to
- (a) Constant force (b) Constant linear momentum
(c) Constant torque (d) Zero torque
64. Four point masses each of the value m , are placed at the corner of a square ABCD of side l . The moment of inertia of this system about an axis passing through (diagonal BD) B D is
- (a) $3 ml^2$ (b) ml^2
(c) $2 ml^2$ (d) $\sqrt{3} ml^2$
65. A couple is acting on a two particle system. The resultant motion will be
- (a) Purely rotational motion (b) Purely linear motion
(c) Both (a) & (b) (d) Neither (a) nor (b)
66. The dimension of angular momentum are
- (a) $[MLT^{-2}]$ (b) $[ML^2T^{-1}]$
(c) $[ML^2T^{-2}]$ (d) $[ML^2T]$
67. Moment of Inertia of an object does not depend up on
- (a) Mass of object (b) Mass distribution
(c) Angular velocity (d) Axis of rotation
68. One circular ring and one circular disc both having same mass and radius. The ratio of their moment of inertia about the axis passing through their centres and perpendicular to their planes will be
- (a) 1 : 1 (b) 2 : 1
(c) 1 : 2 (d) 4 : 1
69. What is the ratio of the moments of inertia of two rings radii r and nr about an axis perpendicular to their plane and passing through their centres?
- (a) 1 : n^2 (b) 1 : n
(c) 1 : $2n$ (d) n^2 : 1

70. Two rings of radii R and nR made from the same wire have the ratio of moments of inertia about an axis passing through their centres equal to $1:8$. The value of n is
- (a) 2 (b) $2\sqrt{2}$
(c) 4 (d) $\frac{1}{2}$
71. The moment of inertia of a ring about one of its diameters is I . What will be the moment of inertia about a tangent parallel to the diameter?
- (a) $4I$ (b) $2I$
(c) $\frac{3}{2}I$ (d) $3I$
72. A person standing on a rotating disc stretches out his hands, the angular speed will
- (a) Increase (b) Decrease
(c) Remains same (d) None of these
73. A sphere of radius ' r ' is rolling without sliding. What is the ratio of rotational kinetic energy and total kinetic energy associated with sphere
- (a) $\frac{2}{7}$ (b) $\frac{2}{5}$
(c) 1 (d) $\frac{1}{2}$
74. A solid sphere of radius ' r ' is rolling with velocity V on a smooth plane. The total kinetic energy of sphere is
- (a) $\frac{7}{10}mv^2$ (b) $\frac{3}{4}mv^2$
(c) $\frac{1}{2}mv^2$ (d) $\frac{1}{4}mv^2$
75. Two bodies have their moment of inertia I and $2I$ respectively about their axis of rotation. If their kinetic energies of rotation are equal, their angular momentum will be in the ratio
- (a) $1:2$ (b) $\sqrt{2}:1$
(c) $2:1$ (d) $1:\sqrt{2}$
76. An inclined plane makes an angle of 30° with horizontal. A solid sphere rolling down this inclined plane has a linear acceleration of
- (a) $\frac{5g}{14}$ (b) $\frac{2g}{3}$
(c) $\frac{2}{3}g$ (d) $\frac{5g}{7}$

77. Planetary motion in the solar system describes
- (a) Conservation of kinetic energy
 - (b) Conservation of linear momentum
 - (c) Conservation of angular momentum
 - (d) All of the above.

ASSERTION - REASON BASED QUESTIONS

Direction for Q.No. 1 to Q.No. 12

The following questions from 1 to 12 consists of two statements each, labelled Assertion (A) and the other labelled Reason (R). While answering these questions, you are required to choose any of the following from options (a), (b), (c) & (d).

- (a) If both A and R are true & R is the correct explanation of A.
 - (b) If both A and R are true & R is NOT the correct explanation of A.
 - (c) If A is true but R is false.
 - (d) If A is false and R is also false.
-
- 1. Assertion (A) : In rolling, all points of a rigid body have the same linear velocity.
Reason (R) : The rotational motion does not affect the linear velocity.
 - 2. Assertion (A) : The speed of a whirl wind in tornado is alarmingly high.
Reason (R) : If no external torque acts on a body, its angular velocity remains constant.
 - 3. Assertion (A) : The velocity of a body at the bottom of an inclined plane of given height is more when it slides down the plane compared when it is rolling down the same plane.
Reason (R) : In rolling down, a body acquires both kinetic energy of translation and rotation.
 - 4. Assertion (A) : Torque is due to the transverse component of force only. The radial component has no role to play.
Reason (R) : This is because transverse component is not perpendicular to radial component.
 - 5. Assertion (A) : Power associated with torque is product of torque and angular speed of the body about the axis of rotation.
Reason (R) : It is rotational analogue of power in translatory motion.

6. Assertion (A) : A wheel moving down a perfectly frictionless inclined plane shall undergo slipping (not rolling)
Reason (R) : For rolling torque is required, which is provided by tangential frictional force.
7. Assertion (A) : Torque is a vector whose direction is along the applied force.
Reason (R) : $\vec{\tau} = \vec{F} \times \vec{r}$
8. Assertion (A) : The centre of mass of a body may lie where there is no mass.
Reason (R) : The centre of mass has nothing to do with the mass of the body.
9. Assertion (A) : To unscrew a rusted nut, we need a wrench with longer arm.
Reason (R) : $\vec{\tau} = \vec{r} \times \vec{F}$
10. Assertion (A) : Moment of inertia of a body is same, whatever be the axis of rotations.
Reason (R) : Moment of inertia depends only a distribution of mass.
11. Assertion (A) : If polar ice melts, days will be longer.
Reason (R) : Moment of inertia decreases and these angular velocity increases.
12. Assertion (A) : Value of radius of gyration of body depends upon axis on rotation.
Reason (R) : Radius of gyration is root near square distance of particles of the body from the axis of rotation.

CASE STUDY BASED QUESTIONS

1. Motion of a rigid body and centre of mass :-

A Point object is only a hypothetical concept. In actual practice, we have bodies or objects which have definite size. An extended object or a real objects is made up of large number of particles. Whereas point object/mass can have only translation motion, extended object can have translational motion, rotational motion & combination of translational & rotational motion as well.

The motion of system of particles or an extended object is quite complicated. This is because every particle of the system moves in a different manner than the other particles of the system. Therefore to describe the overall motion of a body or a system of particles in a simple manner. We define a concept 'Centre of Mass'.

- (i) The centre of mass of a system of particles does not depend on
- position of particles
 - relative distance between the particles
 - forces acting on the particles
 - mass of the particles
- (ii) The centre of mass of a hallow sphere is at the its centre. Centre of mass of the hollow sphere when filled half with sand :
- shifts to A
 - shifts to B
 - shifts to C
 - remains at O
(centre of sphere)

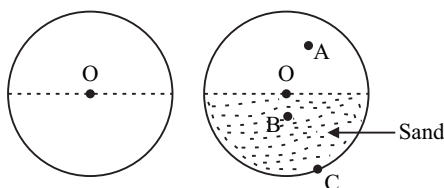

- (iii) For which of the following does the centre of mass outside the body
- a pencil
 - a dice
 - a bangle
 - a shot put
- (iv) Two identical particles move towards each other with velocities $2v$ and v respectively. The velocity of centre of mass is
- v
 - $\frac{v}{3}$
 - $\frac{v}{2}$
 - zero
- (v) A couple is acting on a two particle system. The resultant motion will be
- purely rotational motion
 - purely translatory motion
 - both (a) & (b)
 - neither (a) nor (b)

2. Torque :-

We know that when an external force is applied on a body. It accelerates the body and the body has translation motion. Similarly, a body has rotational motion, upon a force is applied on a body at a certain distance from the axis of rotation of the body. The product of the applied force & distance of the point of application of the force from the axis of rotation its expressed

by a physical quality known as a 'Torque'. Torque is rotational analogue of force. Torque is an axial vector as it points along the axis of rotation.

- (i) The torque about the origin of the force $\vec{F} = mg \hat{j}$ and $\vec{r} = x\hat{i} + y\hat{j}$ is
 (a) $\vec{\tau} = mgx\hat{i}$ (b) $\vec{\tau} = mgy\hat{j}$ (c) $\vec{\tau} = mgx\hat{k}$ (d) $\vec{\tau} = 0$
- (ii) Which of the following statement is false for torque
 (a) $\vec{\tau} = \frac{d\vec{l}}{dt}$ (b) $\vec{\tau} = \vec{r} \times \vec{f}$ (c) $\vec{\tau} = \vec{f} \times \vec{r}$ (d) $\vec{\tau} = I\vec{\alpha}$
- (iii) Let \vec{F} be the force acting on a particle having position vector \vec{r} and $\vec{\tau}$ be the torque of this force about the origin, then
 (a) $\vec{r} \cdot \vec{F} = 0$ and $\vec{F} \cdot \vec{\tau} \neq 0$ (b) $\vec{r} \cdot \vec{\tau} \neq 0$ and $\vec{F} \cdot \vec{\tau} = 0$
 (c) $\vec{r} \cdot \vec{\tau} \neq 0$ and $\vec{F} \cdot \vec{\tau} \neq 0$ (d) $\vec{r} \cdot \vec{\tau} = 0$ and $\vec{F} \cdot \vec{\tau} = 0$
- (iv) Angular momentum of the particle rotating with a central force is constant due to
 (a) constant force (b) constant linear momentum
 (c) constant torque (d) zero torque
- (v) When a disc rotates with uniform angular velocity, which of the following is correct?
 (a) The sense of rotation remains the same
 (b) The orientation of the axis of the rotation remains the same
 (c) The speed of rotation is non-zero & remains the same
 (d) The angular acceleration is non-zero & remains the same.
- (vi) The separation between the C and O atoms in CO is 1.2 \AA . The distance of carbon atom from the centre of mass is
 (a) 0.3 \AA (b) 0.7 \AA (c) 0.5 \AA (d) 0.9 \AA

3. Equilibrium of a rigid body :-

A rigid body is said to be in translational equilibrium, if the net external force acting on the body is zero and it is said to be in rotational equilibrium, if net external torque acting on the body is zero. A rigid body is said to be in partial equilibrium, if either it is in rotational equilibrium but not in translational equilibrium or it is in translational equilibrium but not in rotational equilibrium.

- (i) A couple is acting on rigid body then which statement is true
 (a) The body is in translational equilibrium but not in rotational equilibrium

- (b) The body is in rotational equilibrium but not in translational equilibrium
- (c) The body is in translational as well as in rotational equilibrium
- (d) The body is neither in translational equilibrium nor in rotational equilibrium.
- (ii) For a body in translational equilibrium, which of the following statement is false
- (a) $\sum \vec{F}_{\text{ext}} = 0$ (b) $\vec{p} = 0$ (c) $\vec{v} = 0$ or constant (d) $\vec{a} \neq 0$
- (iii) For a body in rotational equilibrium which of the following is true
- (a) $\sum \vec{\tau}_{\text{ext}} = 0$ (b) $\vec{L} \neq 0$ (c) $\vec{r} \neq 0$ (d) $\vec{\omega} \neq 0$
- (iv) A merry go round, made of a ring like platform of radius R and mass M, is revolving with angular speed ω . A person of mass M is standing on it. At one instant, the person jumps off the round, radially away from the centre of the round (as seen the ground). The speed of the merry go round afterwards is
- (a) 2ω (b) ω (c) $\frac{\omega}{2}$ (d) 0
- (iv) A thin horizontal circular disc is rotating about a vertical axis passing through its centre. An insect is at rest at a point near the rim of the disc. The insect now moves along a diameter of the disc to reach its other end. During the journey of the insect, the angular speed of the disc.
- (a) Continuously decrease
- (b) Continuously increase
- (c) First increases and then decrease
- (d) remaining unchanged

4. Moment of inertia, parallel and perpendicular axis theorem :-

A body rotating about a given axis tends to maintain its state of uniform rotation, unless an external torque is applied on it to change this state. The property of a body by virtue of which it opposes to change its state of rest or uniform rotation about an axis is called rotational inertia or moment of inertia. Moment of inertia is the rotational analogue of mass.

There are two theorem namely theorem of perpendicular axes and theorem of parallel axes, which are used to find the MI of a regular shaped bodies about any axis of rotation. If the value of MI of the given body is known about a certain axis of rotation.

- (i) The moment of inertia (MI) of a body does not depend upon its
- Axis of rotation
 - different orientation of axis of rotation
 - Nature of distribution of mass
 - Angular velocity
- (ii) Which physical quantity is represented by the product of MI and angular acceleration
- Centre of mass
 - Torque
 - Angular momentum
 - Linear momentum
- (iii) The MI of a this uniform rod of length L and mass M, about an axis passing through its one end and perpendicular to its length is
- $\frac{3}{2}ML^2$
 - $\frac{1}{2}ML^2$
 - $\frac{1}{12}ML^2$
 - $\frac{1}{3}ML^2$
- (iv) The radius of gyration of a solid cylinder about its own axis is
- $\frac{R}{2}$
 - $\frac{R}{\sqrt{2}}$
 - 2R
 - $\frac{R}{\sqrt{3}}$
- (v) The MI of a circular ring of radius R and mass M about its diameter is
- MR^2
 - $\frac{1}{2}MR^2$
 - $\frac{3}{2}MR^2$
 - $2MR^2$

5. Rolling Motion :-

One of the most common motion observed in daily life is the rolling motion. All wheels used in transportation have rolling motion. Rolling motion can be regarded as a combination of pure rotation and pure translation (without slipping). This means that at any instant of time, the bottom of the body which is in contact with the surface is at rest always.

Total kinetic energy of a rolling body is the sum of translational kinetic energy and rotational kinetic energy of the rolling body.

- (i) For a pure rolling (without slipping) of a spherical rigid body when of the following friction is not correct.
- During pure rolling, the force of friction acts in the same direction as the direction of motion of the CM of the body
 - The instantaneous speed of the point of contact during rolling is zero.
 - For perfect rolling, work done against friction is zero.
 - A sphere moving down a perfectly frictional inclined plane will undergo pure rolling motion.

- (ii) A spherical body is rolling over a horizontal surface w/o slipping such that the velocity of centre of mass (CM) of the body is 3 m/s. The velocity of point A & B on the body at any instant is

- (a) 0 m/s, 6 m/s
 (b) 0 m/s, 3 m/s
 (c) 3 m/s, 0 m/s
 (d) 6 m/s, 0 m/s

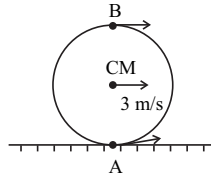

- (iii) A sphere of radius 1m is rolling over a horizontal floor w/o slipping with an angular velocity of 1 rad/s. The linear velocity of the centre of mass (CM) of the sphere is

- (a) $\frac{1}{2}$ m/s (b) 1 m/s (c) 2 m/s (d) at rest

- (iv) A solid sphere and hollow sphere both of same mass and same radius and made of same material are allowed to roll down on inclined plane, then

- (a) solid sphere reaches the bottom first
 (b) hollow sphere reaches the bottom first
 (c) both reach the bottom at the same time
 (d) cannot say

- (v) If a solid sphere of mass 1 kg and radius 0.1 m rolls w/o slipping at a uniform velocity of 1 m/s, along a straight line on a horizontal floor, then kinetic energy of the sphere is

- (a) $\frac{2}{5}$ J (b) 1 J (c) $\frac{7}{10}$ J (d) $\frac{7}{5}$ J

ANSWERS (ROTATIONAL MOTION) 1 MARK

- It will be about an axis passing through the centre of the cube and connecting the opposite corners.
- $\Sigma \vec{\tau} = 0$.
- $\frac{1}{2} MR^2$.
- No. It can produce only rotatory motion.
- Radial Component.
- P.E. is minimum.
- No, it changes with the position of axis of rotation.

8. Sphere of small density will have large moment of inertia.
9. $K = \frac{L^2}{2I} \Rightarrow K_B > K_A$.
10. as $\vec{L} = \vec{r} \times m \vec{v}$ i.e., magnitude \vec{L} decreases but direction remains constant.
11. Zero.
12. Angular momentum of planet.
13. Zero.
14. No. $\omega \propto \frac{1}{I}$.
15. Due to conservation of angular momentum.
16. No change in speed of system as no external force is working.

ANSWERS (2 MARKS)

18. (i) Shape of body
(ii) mass distribution
19. Torque
Factors
(i) Magnitude of force
(ii) Perpendicular distance of force vector from axis of rotation.
20. (i) Mass of body
(ii) Size and shape of body
(iii) Mass distribution w.r.t. axis of rotation
(iv) Position and orientation of rotational axis
21. Mass distribution.
22. In this, air from nearby regions get concentrated in a small space, so $I \downarrow$ considerably. Since $I.W = \text{constant}$ so $W \uparrow$, so high.
23. Yes, if body has no linear and angular acceleration. Hence a body in uniform straight line motion will be in equilibrium.

24. I (first case) $>$ I (Second case)

$$\therefore \tau = I\alpha$$

$\Rightarrow \alpha$ (first case) $<$ α (second case)

25.
$$I_1 = \frac{2}{5}MR^2 \Rightarrow I_2 = \frac{2}{5}M\left(\frac{R}{2}\right)^2 \Rightarrow I_2 = \frac{I_1}{4}$$

$$L = I_1\omega_1 = I_2\omega_2$$

or
$$I\left(\frac{2\pi}{T_1}\right) = \frac{1}{4}\left(\frac{2\pi}{T_2}\right)$$

or
$$T_2 = \frac{T_1}{4} = \frac{24}{4} = 6 \text{ hours}$$

26. In this case the force which bring the vehicle to rest is friction, and it is an external force.

27. For translation equilibrium

$$\Sigma \vec{F}_{\text{ext}} = 0$$

For rotational equilibrium

$$\Sigma \vec{\tau}_{\text{ext}} = 0$$

28. For same external torque, angular acceleration of raw egg will be small than that of Hard boiled egg.

29.
$$\tau = I\alpha, \alpha = \frac{\tau}{I}$$

α in cylinder,
$$\alpha_C = \frac{\tau}{I_C}$$

α in sphere,
$$\alpha_S = \frac{\tau}{I_S}$$

$$\frac{\alpha_C}{\alpha_S} = \frac{I_S}{I_C} = \frac{\frac{2}{5}MR^2}{MR^2} = \frac{2}{5}$$

30. When vertical line through centre of gravity passes through the base of the body.

31. It plays the same role in rotatory motion as the mass does in translatory motion.

ANSWERS (3 MARKS)

35.

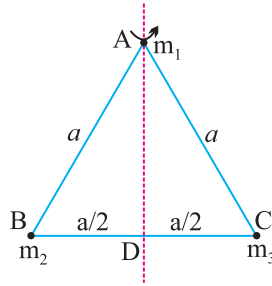

$$\begin{aligned}
 I &= \sum_{i=1}^n m_i r_i^2 \\
 &= m_1 \times 0 + m_2 \times (BD)^2 + m_3 \times (DC)^2 \\
 &= 0 + m_2 \left(\frac{a}{2}\right)^2 + m_3 \left(\frac{a}{2}\right)^2 \\
 I &= \frac{1}{4}(m_2 + m_3)a^2
 \end{aligned}$$

37. For A, $V_A = R\omega_0$ in forward direction

For B, $V_B = R\omega_0$ in backward direction

For C, $V_C = \frac{R}{2}\omega_0$ in forward direction disc will not roll.

$$41. \quad \vec{\tau} = \vec{r} \times \vec{F} = \begin{vmatrix} \hat{i} & \hat{j} & \hat{k} \\ 1 & 1 & -1 \\ 7 & -3 & -5 \end{vmatrix} = -8\hat{i} - 2\hat{j} - 10\hat{k}$$

ANSWERS (NUMERICALS)

42. $(x, y) = (0.54 \text{ m}, 0.36 \text{ m})$

43. Velocity of COM = $\frac{31i - 34j + 15k}{2} \text{ ms}^{-1}$.

44. COM of resulting portion lies at $R/6$ from the centre of the original disc in a direction opposite to the centre of the cut out portion.

45. $\alpha = 4\pi \text{ rad s}^{-1}$

$$n = 576$$

46. $m = 66.0 \text{ gm}$.

47.
$$\text{Rot. K.E.} = \frac{1}{2} I \omega^2 = \frac{1}{2} \times \frac{2}{5} MR^2 \times \frac{V^2}{R^2}$$

$$\left(\text{as } \omega = \frac{V}{R}, I = \frac{2}{5} MR^2 \right)$$

$$= \frac{1}{5} mv^2$$

$$\text{Total energy} = \text{Translational K.E.} + \text{Rot. K.E.}$$

$$= \frac{1}{2} mv^2 + \frac{1}{5} mv^2 = \frac{7}{10} mv^2$$

$$\therefore \frac{\text{Rot. K.E.}}{\text{Total Energy}} = \frac{\frac{1}{5} mv^2}{\frac{7}{10} mv^2} = \frac{2}{7}$$

48. $\sqrt{2} : 1$

49. (i) Let ω be the angular speed of the two-disc system. Then by conservation of angular momentum.

$$(I_1 + I_2) \omega = I_1 \omega_1 + I_2 \omega_2$$

or
$$\omega = \frac{I_1 \omega_1 + I_2 \omega_2}{I_1 + I_2}$$

(ii) Initial K.E. of the two discs.

$$K_1 = \frac{1}{2} I_1 \omega_1^2 + \frac{1}{2} I_2 \omega_2^2$$

Final K.E. of the two disc system.

$$K_2 = \frac{1}{2} (I_1 + I_2) \omega^2$$

$$= \frac{1}{2} (I_1 + I_2) \left(\frac{I_1 \omega_1 + I_2 \omega_2}{I_1 + I_2} \right)^2$$

$$\text{Loss in K.E.} = K_1 - K_2 = \frac{1}{2} (I_1 \omega_1^2 + I_2 \omega_2^2) - \frac{1}{2} (I_1 \omega_1 + I_2 \omega_2)^2$$

$$= \frac{I_1 I_2}{2(I_1 + I_2)} (\omega_1 - \omega_2)^2 = \text{a positive quantity} [\because \omega_1 \neq \omega_2]$$

Hence there is a loss of rotational K.E. which appears as heat.

When the two discs are brought together, work is done against friction between the two discs.

50. As shown in Fig. suppose the H nucleus is located at the origin. Then

$$x_1 = 0, x_2 = 1.27 \text{ \AA}, m_1 = 1, m_2 = 35.5$$

The position of the CM of HCl molecule is

$$x = \frac{m_1 x_1 + m_2 x_2}{m_1 + m_2}$$

$$\frac{1 \times 0 + 35.5 \times 1.27}{1 + 35.5} = 1.239 \text{ \AA}$$

Thus the CM of HCl is located on the line joining H and Cl nuclei at a distance of 1.235 Å from the H nucleus.

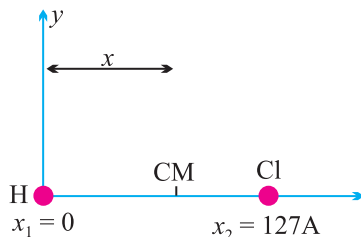

51. Here $\omega_1 = 40 \text{ rpm}$, $I_2 = \frac{2}{5} I_1$

By the principle of conservation of angular momentum,

$$I_1 \omega_1 = I_2 \omega_2 \text{ or } I_1 \times 40 = \frac{2}{5} I_1 \omega_2 \text{ or } \omega_2 = 100 \text{ rpm.}$$

(ii) Initial kinetic energy of rotation

$$\frac{2}{5} I_1 \omega_1^2 = \frac{2}{5} I_1 (40)^2 = 800 I_1$$

New kinetic energy of rotation

$$\frac{2}{5} I_2 \omega_2^2 = \frac{1}{2} \times \frac{2}{3} I_1 (100)^2 = 2000 I_1$$

$$\frac{\text{New K.E.}}{\text{Initial K.E.}} = \frac{2000 I_1}{800 I_1} = 2.5$$

Thus the child's new kinetic energy of rotation is 2.5 times its initial kinetic energy of rotation. This increase in kinetic energy is due to the internal energy

of the child which he uses in folding his hands back from the out stretched position.

52. Here $\omega = 200 \text{ rad s}^{-1}$, $\tau = 180 \text{ Nm}$

\therefore Power, $P = \tau \omega = 180 \times 200 = 36,000 \text{ W} = 36 \text{ kW}$.

53.

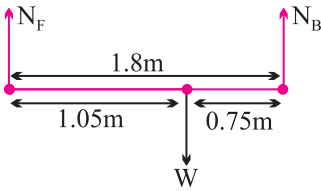

For translation equilibrium of car

$$N_F + N_B = W = 1800 \times 9.8 = 17640 \text{ N}$$

For rotational equilibrium of car

$$1.05 N_F = 0.75 N_B$$

$$1.05 N_F = 0.75 (17640 - N_F)$$

$$1.8 N_F = 13230$$

$$N_F = 13230/1.8 = 7350 \text{ N}$$

$$N_B = 17640 - 7350 = 10290 \text{ N}$$

Force on each front wheel = $\frac{7350}{2} = 3675 \text{ N}$

Force on each back wheel = $\frac{10290}{2} = 5145 \text{ N}$

ANSWERS (5 MARKS)

56. (ii) Yes, a body in translatory motion shall have angular momentum unless fixed point about which angular momentum is taken lies on the line of motion of body

$$\begin{aligned} \therefore |\bar{L}| &= rp \sin \theta \\ &= 0 \text{ only when } \theta = 0^\circ \text{ or } 180^\circ \end{aligned}$$

(iv) MI of stone $I = ml^2$ ($l \rightarrow$ length of string)

$$\tau = I\alpha$$

$$\alpha = \frac{\tau}{I} = \frac{\tau}{ml^2}$$

if l is large α is very small

\therefore more difficult to revolve.

Answer (MCQ) Key :

58. (d) 59. (d) 60. (c) 61. (a) 62. (b) 63. (d)
 64. (a) 65. (a) 66. 67. 68. (b) 69. (a)
 70. (a) 71. (d) 72. (b) 73. (a) 74. (a) 75. (d)
 76. (a) 77. (c)

HINTS AND SOLUTION (MCQ)

58. (d) In bangle centre of mass lies at it's centre.

59. (d) $\alpha = \frac{dw}{dt}$, given $w = \text{constant}$

Hence $\alpha = 0$

60. (c) $V_{\text{cm}} = \frac{m_1 v_1 + m_2 v_2}{m_1 + m_2} = \frac{m(2v) + m(-v)}{2m} = \frac{V}{2}$

61. (a) Mass of original disc = m

Mass of disc removed, $m_1 = \frac{m}{4}$

Mass of remaining disc = $\frac{3m}{4}$

Mass m_1 and m_2 are concentrated at O_1 and O_2 respectively and O is their centre of mass.

Moment of m_1 about O = moment of m_2 about O .

$$\frac{m}{4} \times R = \frac{3m}{R} \times \alpha R \Rightarrow \alpha = \frac{1}{3}$$

62. Mass of elementary disc,

$$dm = \pi r^2 dz$$

$$\frac{r}{R} = \frac{z}{h} \Rightarrow r = \frac{Rz}{h}$$

$$Z_o = \frac{\int z dm}{\int dm} = \frac{\int_0^h \pi r^2 dz}{\frac{1}{3} \pi R^2 h} = \frac{3}{4} h$$

63. (d) Torque due to central force is zero

$$\tau = \frac{dL}{dt} = 0 \Rightarrow L = \text{constant.}$$

64. (a) $AC = BD = \sqrt{2} \ell$

$$I_{BD} = m(AO)^2 + m(CO)^2 = ml^2$$

65. (a) Net force for a couple is zero.

So, couple produces only rotational motion.

66. (b) $\vec{L} = \vec{r} \times \vec{p}$ $[L] = [M L^2 T^{-1}]$

67. (c) M.I. does not depend up on angular velocity.

68. (b) $\frac{I_{\text{ring}}}{I_{\text{disc}}} = \frac{mR^2}{\frac{1}{2}mR^2} = 2 : 1$

69. (a) $\frac{I_1}{I_2} = \frac{Mr^2}{m(nr)^2} = 1 : n^2$

70. (a) As radius of round ring is n times, length and hence mass of wire is also n times

$$\frac{I_1}{I_2} = \frac{mR^2}{nM(nR)^2} = \frac{1}{n^3} = \frac{1}{8} \Rightarrow n = 2$$

71. (d) $I_T = I + mR^2 = \frac{1}{2}mR^2 + mR^2$
 $= 3 \times \frac{1}{2}mR^2 = 3I$

72. (b) As person stretches his hands outward, hence moment of inertia, $I =$ increases

$L = I\omega =$ constant, So ω decreases.

73. (a)

$$E_T = E_{\text{trans}} + E_{\text{rot}} = \frac{1}{2} mV^2 + \frac{1}{2} I\omega^2$$

$$I = \frac{2}{5}mr^2, E_T = \frac{7}{10} mV^2$$

$$\frac{E_{\text{rot}}}{E_{\text{trans}}} = \frac{\frac{1}{5}mV^2}{\frac{7}{10}mV^2} = \frac{2}{7}$$

74. (a) $E_T = E_{\text{trans}} + E_{\text{rot}} = \frac{7}{10} mV^2$
75. (d) Rotational K.E. = $\frac{1}{2} I\omega^2$
 $\frac{1}{2} I_1 \omega_1^2 = \frac{1}{2} I_2 \omega_2^2 \Rightarrow \omega_2 = \frac{\omega_1}{\sqrt{2}}$
 $\frac{L_1}{L_2} = \frac{1}{\sqrt{2}}$
76. (a) $a = \frac{5}{7}g \sin 30^\circ = \frac{5g}{14}$
77. (c) $T_{\text{ext}} = 0$ So $\frac{d\vec{L}}{dt} = 0$
 $\Rightarrow \vec{L} = \text{constant.}$

ASSERTION - REASON BASED ANSWERS

- (d) both A & R are false. In case of rolling body, all points on it have same angular velocity but different linear speed. Linear speed is different at different places. It is the maximum at highest point and minimum at lowest point.
- (c) here assertion is true but reason is false.
 Assertion is true as per conservation of angular momentum but when no external torque acts on the body, its angular momentum is constant not angular velocity.
- (b) both A & R are true but R is not the correct explanation of A. When a body slides its PE is converted into KE of translation, but when it rolls down, some part of its PE is converted into its KE of rotation, thereby reducing the KE of translation and hence its linear velocity.
- (c) A is true but R false.
- (a) both A & R are true & R is the correct explanation of A.
 In translatory motion $P = FV$.
 In rotatory motion $P = I\omega$.
- (a) both A & R are true and R is the correct explanation of A.
- (d) both A & R are false.
 $\vec{\tau} = \vec{r} \times \vec{F}$ so $\vec{\tau}$ is \perp to r to the force.

8. (c) A is true but R is false.
CM depends upon the distribution of mass.
9. (a) both A & R are true and R is the correct explanation of A.
10. (d) both A & R are false.
11. (c) A is true but R is false. When ice melts, MI increases and hence angular velocity decreases.
$$L = I\omega = \text{constant}$$
12. (a) both A & R are true and R is the correct explanation of A.

CASE STUDY BASED ANSWERS

1. i. (c) forces acting on the particle
ii. (b) shifts to B.
iii. (c) a bangle
iv. (c) $\frac{v}{2} = \left[\text{use } V_{\text{CM}} = \frac{m_1 \vec{v}_1 + m_2 \vec{v}_2}{m_1 + m_2} \right]$
v. (a) purely rotational motion
2. i. (c) $\vec{\tau} = \vec{r} \times \vec{F}$
$$\vec{\tau} = (x\hat{i} + y\hat{j}) \times mg\hat{j}$$
$$= mgx(\hat{i} \times \hat{j})$$
$$= mgx \hat{k}$$

ii. (c) $\vec{\tau} = \vec{F} \times \vec{r}$
iii. (d) $\vec{r} \cdot \vec{\tau} = 0$ and $\vec{F} \cdot \vec{\tau} = 0$ [as vector $\vec{\tau}$ is \perp r to both \vec{r} & \vec{F}]
[so $\vec{r} \cdot \vec{\tau} = 0$ and also $\vec{F} \cdot \vec{\tau} = 0$]
iv. (d) Zero torque [as $\frac{d\vec{\tau}}{dt} = \vec{\tau}_{\text{ent}}$ so then $\vec{\tau}_{\text{ent}} = 0$
then $\frac{d\tau}{dt} = 0 \Rightarrow \tau = \text{constant}$
v. (d) The angular acceleration is non-zero & remains the same.
3. i. (a) ii. (d) iii. (a)
iv. (a) v. (c)

4. i. (a)
 ii. (b)
 iii. (d) using parallel ones theorem.
 iv. (b) as radius of gravitation = $\sqrt{\frac{I}{M}}$
 v. (b) using perpendicular are theorem.
5. i. (d)
 ii. (a)
 iii. (b) as $V_{CM} = r\omega$
 iv. (a) $I_{\text{solid sphere}} < I_{\text{hallow sphere}}$ so $a_{\text{solid sphere}} > a_{\text{hallow sphere}}$

$$a = \frac{\int \sin \theta}{\left[1 + \frac{I}{MR^2}\right]}$$

v. (c) $\frac{7}{10} \text{ J}$ $[\text{KE} = -mv^2 + \frac{1}{2}I\omega^2$

$$= \frac{1}{2}mv^2 + \frac{1}{2} \cdot \frac{7}{5} MR^2 \times \frac{v^2}{R^2}$$

$$= \frac{7}{10} MV^2$$

$$= \frac{7}{10} \times 1 \times 1 \times 1 = \frac{7}{10} \text{ J}]$$

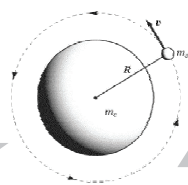

Unit - 6

Gravitation

6.1 Newton's Law of Gravitation

Newton's law of gravitation states that every body in this universe attracts every other body with a force, which is directly proportional to the product of their masses and inversely proportional to the square of the distance between their centres. The direction of the force is along the line joining the particles.

Thus the magnitude of the gravitational force F that two particles of masses m_1 and m_2 separated by a distance r exert on each other is given by $F \propto \frac{m_1 m_2}{r^2}$.

or

$$F = G \frac{m_1 m_2}{r^2}$$

Also clear that $\vec{F}_{12} = -\vec{F}_{21}$. Which is Newton's third law of motion.

Here G is constant of proportionality which is called 'Universal gravitational constant'.

- (i) The value of G is $6.67 \times 10^{-11} \text{ N-m}^2 \text{ kg}^{-2}$ in S.I and $6.67 \times 10^{-8} \text{ dyne-cm}^2 \text{ g}^{-2}$ in C.G.S. system.
- (ii) Dimensional formula $[M^{-1}L^3T^{-2}]$.
- (iii) The value of G does not depend upon the nature and size of the bodies.
- (iv) It does not depend upon the nature of the medium between the two bodies.

6.2 Acceleration Due to Gravity

The force of attraction exerted by the earth on a body is called gravitational pull or gravity.

The acceleration produced in the motion of a body under the effect of gravity is called acceleration due to gravity, it is denoted by g .

If M = mass of the earth and R = radius of the earth and g is the acceleration

due to gravity, then

$$\therefore g = \frac{GM}{R^2} = \frac{4}{3}\pi\rho GR$$

- (i) Its value depends upon the mass radius and density of planet and it is independent of mass, shape and density of the body placed on the surface of the planet.
- (ii) Acceleration due to gravity is a vector quantity and its direction is always towards the centre of the planet.
- (iii) Dimension $[g] = [LT^{-2}]$
- (iv) It's average value is taken to be 9.8 m/s^2 or 981 cm/sec^2 , on the surface of the earth at mean sea level.

6.3 Variation in g with Height

Acceleration due to gravity at height h from the surface of the earth

$$g = \frac{GM}{(R+h)^2}$$

Also

$$g' = g \left(\frac{R}{R+h} \right)^2$$
$$= g \frac{R^2}{r^2} \quad [\text{As } r = R + h]$$

(i) If $h \ll R$

$$g' = g \left[1 - \frac{2h}{R} \right]$$

(ii) If $h \ll R$. Percentage decrease $\frac{\Delta g}{g} \times 100\% = \frac{2h}{R} \times 100\%$.

6.4 Variation in g with Depth

Acceleration due to gravity at depth d from the surface of the earth

$$g' = \frac{4}{3}\pi\rho G(R-d)$$

also g'

$$= g \left[1 - \frac{d}{R} \right]$$

- (i) The value of g decreases on going below the surface of the earth.
- (ii) The acceleration due to gravity at the centre of earth becomes zero.

(iii) Percentage decrease $\frac{\Delta g}{g} \times 100\% = \frac{d}{R} \times 100\%$.

(iv) The rate of decrease of gravity outside the earth (if $h \ll R$) is double to that of inside the earth.

6.5 Gravitational Field

The space surrounding a material body in which gravitational force of attraction can be experienced is called its gravitational field.

Gravitational Field intensity : The intensity of the gravitational field of a material body at any point in its field is defined as the force experienced by a unit mass (test mass) placed at that point. If a test mass m at a point in a

gravitational field experiences a force \vec{F} then $\vec{I} = \frac{\vec{F}}{m}$.

6.6 Gravitational Potential

At a point in a gravitational field potential V is defined as negative of work done per unit mass in shifting a test mass from some reference point (usually at infinity) to the given point.

Negative sign indicates that the direction of intensity is in the direction where the potential decreases.

$$\text{Gravitational potential } V = -\frac{GM}{r}$$

6.7 Gravitational Potential Energy

The gravitational potential energy of a body at a point is defined as the amount of work done in bringing the body from infinity to that point against the gravitational force.

$$W = -\frac{GMm}{r}$$

This work done is stored inside the body as its gravitational potential energy

$$\therefore U = -\frac{GMm}{r}$$

If $r = \infty$ then it becomes zero (maximum).

6.8 Escape Velocity

The minimum velocity with which a body must be projected up so as to enable it to just overcome the gravitational pull, is known as escape velocity.

If v_e is the required escape velocity, then

$$v_e = \sqrt{\frac{2GM}{R}} \quad \Rightarrow \quad v_e = \sqrt{2gR}$$

- (i) Escape velocity is independent of the mass and direction of projection of the body.
- (ii) For the earth, $v_e = 11.2 \text{ km/sec}$
- (iii) A planet will have atmosphere if the velocity of molecule in its atmosphere is lesser than escape velocity. This is why earth has atmosphere while moon has no atmosphere.

6.9 Kepler's laws of Planetary Motion

- (1) **The law of Orbits :** Every planet moves around the sun in an elliptical orbit with sun at one of the foci.
- (2) **The law of Area :** The line joining the sun to the planet sweeps out equal areas in equal interval of time. *i.e.*, areal velocity is constant. According to this law planet will move slowly when it is farthest from sun and more rapidly when it is nearest to sun. It is similar to law of conservation of angular momentum.

Areal velocity $\frac{dA}{dt} = \frac{L}{2m}$

- (3) **The law of periods :** The square of period of revolution (T) of any planet around sun is directly proportional to the cube of the semi-major axis of the orbit.

$$T^2 \propto a^3 \text{ or } T^2 \propto \left(\frac{r_1 + r_2}{2} \right)^3$$

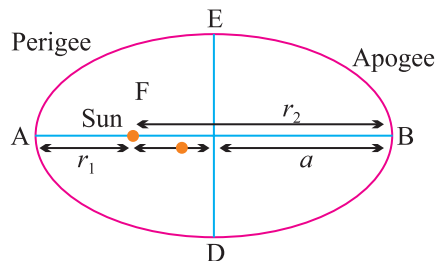

where a = semi-major axis

r_1 = Shortest distance of planet from sun (perigee).

r_2 = Largest distance of planet from sun (apogee).

- Kepler's laws are valid for satellites also.

6.10 Orbital Velocity of Satellite

$$\Rightarrow v = \sqrt{\frac{GM}{r}} \quad [r = R + h]$$

- (i) Orbital velocity is independent of the mass of the orbiting body.
- (ii) Orbital velocity depends on the mass of planet and radius of orbit.
- (iii) Orbital velocity of the satellite when it revolves very close to the surface of the planet, (earth is)

$$v = \sqrt{\frac{GM}{r}} = \sqrt{gR} \approx 8 \text{ km/sec} \quad \begin{matrix} [r = R + h] \\ [h = 0] \end{matrix}$$

6.11 Time Period of Satellite

$$T = 2\pi\sqrt{\frac{(R+h)^3}{gR^2}} = 2\pi\sqrt{\frac{R}{g}}\left(1 + \frac{h}{R}\right)^{3/2} \quad [\text{As } r = R + h]$$

- (i) Time period is independent of the mass of orbiting body
- (ii) $T^2 \propto r^3$ (Kepler's third law)

(iii) Time period of nearby satellite, $T = 2\pi\sqrt{\frac{R}{g}}$

For earth $T = 84.6 \text{ minute} \approx 1.4 \text{ hr.}$

6.12 Height of Satellite

$$h = \left(\frac{T^2 g R^2}{4\pi^2}\right)^{1/3} - R$$

6.13 Geostationary Satellite

The satellite which appears stationary relative to earth is called geostationary or geosynchronous satellite, communication satellite.

A geostationary satellite always stays over the same place above the earth. The orbit of a geostationary satellite is known as the parking orbit.

- (i) It should revolve in an orbit concentric and coplanar with the equatorial plane.
- (ii) Its sense of rotation should be same as that of earth.
- (iii) Its period of revolution around the earth should be same as that of earth.

- (iv) Height of geostationary satellite from the surface of earth $h = 6R = 36000$ km.
- (v) Orbital velocity $v = 3.08$ km/sec.
- (vi) Angular momentum of satellite depend on both the mass of orbiting and planet as well as the radius of orbit.

6.14 Energy of Satellite

(1) Potential energy : $U = \frac{-GMm}{r} = \frac{-L^2}{mr^2}$

(2) Kinetic energy : $K = \frac{1}{2}mv^2 = \frac{GMm}{2r} = \frac{L^2}{2mr^2}$

(3) Total energy : $E = U + K = \frac{-GMm}{r} + \frac{GMm}{2r} = \frac{-GMm}{2r} = -\frac{L^2}{2mr^2}$

(4) Energy graph for a satellite

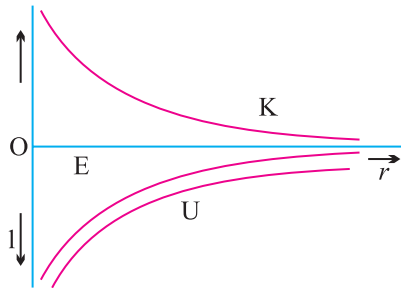

- (5) **Binding Energy** : The energy required to remove the satellite its orbit to infinity is called Binding Energy of the system, *i.e.*,

$$\text{Binding Energy (B.E.)} = -E = \frac{GMm}{2r}$$

6.15 Weightlessness

The state of weightlessness (zero weight) can be observed in the following situations.

- (1) When objects fall freely under gravity
- (2) When a satellite revolves in its orbit around the earth
- (3) When bodies are at null points in outer space. The zero gravity region is called null point.

Very Short Answer Type Questions (1 Mark)

1. The mass of moon is nearly 10% of the mass of the earth. What will be the gravitational force of the earth on the moon, in comparison to the gravitational force of the moon on the earth ?
2. Why does one feel giddy while moving on a merry go round ?
3. Name two factors which determine whether a planet would have atmosphere or not.
4. The force of gravity due to earth on a body is proportional to its mass, then why does a heavy body not fall faster than a lighter body ?
5. The force of attraction due to a hollow spherical shell of uniform density on a point mass situated inside is zero, so can a body be shielded from gravitational influence ?
6. The gravitational force between two bodies is 1 N if the distance between them is doubled, what will be the force between them ?
7. A body of mass 5 kg is taken to the centre of the earth. What will be its (i) mass, (ii) weight there.
8. Why is gravitational potential energy negative ?
9. A satellite revolves close to the surface of a planet. How is its orbital velocity related with escape velocity of that planet.
10. Two satellites A and B are orbiting around the earth in circular orbits of the same radius and mass of A is 16 times that of B. What is the ratio of the period of revolution of B to that of A ?
11. Identify the position of sun in the following diagram if the linear speed of the planet is greater at C than at D.

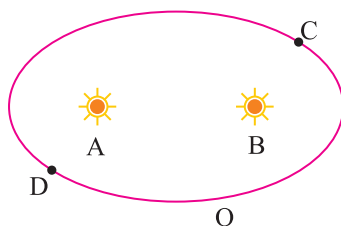

12. A satellite does not require any fuel to orbit the earth. Why ?
13. A satellite of small mass burns during its descent and not during ascent. Why ?

14. Is it possible to place an artificial satellite in an orbit so that it is always visible over New Delhi ?
15. If the density of a planet is doubled without any change in its radius, how does 'g' change on the planet.
16. Why is the weight of a body at the poles more than the weight at the equator ? Explain.
17. Why an astronaut in an orbiting space craft is not zero gravity although he is in weight lessness ?
18. Write one important use of (i) geostationary satellite, (ii) polar satellite.
19. A binary star system consists of two stars A and B which have time periods T_A and T_B , radius R_A and R_B and masses m_A and m_B which of the three quantities are same for the stars. Justify.
20. The time period of the satellite of the earth is 5 hr. If the separation between earth and satellite is increased to 4 times the previous value, then what will be the new time period of satellite.
21. Why does the earth impart the same acceleration to every bodies ?
22. If suddenly the gravitational force of attraction between earth and satellite become zero, what would happen to the satellite ?

Short Answer Type Questions (2 Marks)

23. If the radius of the earth were to decrease by 1%, keeping its mass same, how will the acceleration due to gravity change ?
24. Which of the following symptoms is likely to affect an astronaut in space (a) swollen feet, (b) swollen face, (c) headache, (d) orientation problem.
25. A satellite is moving round the earth with velocity v_0 what should be the minimum percentage increase in its velocity so that the satellite escapes.
26. The radii of two planets are R and $2R$ respectively and their densities ρ and $\rho/2$ respectively. What is the ratio of acceleration due to gravity at their surfaces ?

27. If earth has a mass 9 times and radius 4 times than that of a planet 'P'. Calculate the escape velocity at the planet 'P' if its value on earth is 11.2 kms^{-1} .
28. At what height from the surface of the earth will the value of 'g' be reduced by 36% of its value at the surface of earth.
29. At what depth is the value of 'g' same as at a height of 40 km from the surface of earth.
30. The mean orbital radius of the earth around the sun is $1.5 \times 10^8 \text{ km}$. Calculate mass of the sun if $G = 6.67 \times 10^{-11} \text{ N m}^2/\text{kg}^{-2}$?
31. Draw graphs showing the variation of acceleration due to gravity with (i) height above earth is surface (ii) depth below the earth's surface.
32. A rocket is fired from the earth towards the sun. At what point on its path is the gravitational force on the rocket zero ? Mass of sun = $2 \times 10^{30} \text{ kg}$, mass of the earth = $6 \times 10^{24} \text{ kg}$. Neglect the effect of other planets etc. Orbital radius = $1.5 \times 10^{11} \text{ m}$.
33. If the earth is one half its present distance from the sun. How many days will be present one year on the surface of earth will change ?
34. A body weighs 63 N on the surface of the earth. What is the gravitational force on it due to the earth at a height equal to half the radius of the earth ?
35. Why the space rockets are generally launched west to east ?
36. Explain why a tennis ball bounces higher on hills than in plane ?
37. The gravitational force on the earth due to the sun is greater than moon. However tidal effect due to the moon's pull is greater than the tidal effect due to sun. Why ?
38. The mass of moon is $\frac{M}{81}$ (where M is mass of earth). Find the distance of the point where the gravitational field due to earth and moon cancel each other. Given distance of moon from earth is 60 R, where R is radius of earth.

39. The figure shows elliptical orbit of a planet m about the sun S . The shaded area of SCD is twice the shaded area SAB . If t_1 is the time for the planet to move from D to C and t_2 is time to move from A to B , what is the relation between t_1 and t_2 ?

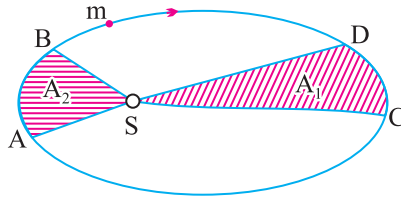

40. Calculate the energy required to move a body of mass m from an orbit of radius $2R$ to $3R$.
41. A man can jump 1.5 m high on earth. Calculate the height he may be able to jump on a planet whose density is one quarter that of the earth and whose radius is one third of the earth.

Short Answer Type Questions (3 Marks)

42. Define gravitational potential at a point in the gravitational field. Obtain a relation for it. What is the position at which it is (i) maximum (ii) minimum.
43. Find the potential energy of a system of four particles, each of mass m , placed at the vertices of a square of side a . Also obtain the potential at the centre of the square.
44. Three mass points each of mass m are placed at the vertices of an equilateral triangle of side l . What is the gravitational field and potential at the centroid of the triangle due to the three masses.
45. Briefly explain the principle of launching an artificial satellite. Explain the use of multistage rockets in launching a satellite.
46. In a two stage launch of a satellite, the first stage brings the satellite to a height of 150 km and the 2nd stage gives it the necessary critical speed to put it in a circular orbit. Which stage requires more expenditure of fuel? Given mass of earth = 6.0×10^{24} kg, radius of earth = 6400 km.
47. The escape velocity of a projectile on earth's surface is 11.2 km s^{-1} . A body is projected out with thrice this speed. What is the speed of the body far away from the earth? Ignore the presence of the sun and other planets.

48. A satellite orbits the earth at a height 'h' from the surface. How much energy must be expended to rocket the satellite out of earth's gravitational influence ?
49. Define gravitational potential. Give its SI units.
50. What do you mean by gravitational potential energy of a body ? Obtain an expression for it for a body of mass m lying at distance r from the centre of the earth.
51. What is the minimum energy required to launch a satellite of mass m kg from the earth's surface of radius R in a circular orbit at an altitude of $2R$?

Long Answer Type Questions (5 Marks)

52. What is acceleration due to gravity ?
Obtain relations to show how the value of 'g' changes with (i) altitude, (ii) depth.
53. Define escape velocity obtain an expression for escape velocity of a body from the surface of earth ? Does the escape velocity depend on (i) location from where it is projected (ii) the height of the location from where the body is launched.
54. State Kepler's three laws of planetary motion. Prove the second and third law. Name the physical quantities which remain constant during the planetary motion.
55. Derive expression for the orbital velocity of a satellite and its time period.
What is a geostationary satellite. Obtain the expression for the height of the geostationary satellite.
56. State and derive Kepler's law of periods (or harmonic law) for circular orbits.
57. A black hole is a body from whose surface nothing may ever escape. What is the condition for a uniform spherical mass M to be a black hole ? What should be the radius of such a black hole if its mass is the same as that of the earth ?

Numericals

58. The mass of planet Jupiter is 1.9×10^{27} kg and that of the sun is 1.99×10^{30} kg. The mean distance of Jupiter from the Sun is 7.8×10^{11} m. Calculate gravitational force which sun exerts on Jupiter, and the speed of Jupiter.
59. A mass 'M' is broken into two parts of masses m_1 and m_2 . How are m_1 and m_2 related so that force of gravitational attraction between the two parts is maximum.
60. If the radius of earth shrinks by 2%, mass remaining constant. How would the value of acceleration due to gravity change ?
61. A body released at the distance r ($r > R$) from the centre of the earth. What is the velocity of the body when it strikes the surface of the earth ?
62. How far away from the surface of earth does the acceleration due to gravity become 4% of its value on the surface of earth ? Radius of earth = 6400 km.
63. The gravitational field intensity at a point 10,000 km from the centre of the earth is 4.8 N kg^{-1} . Calculate gravitational potential at that point.
64. A geostationary satellite orbits the earth at a height of nearly 36000 km. What is the potential due to earth's gravity at the site of this satellite (take the potential energy at ∞ to be zero). Mass of earth is 6×10^{24} kg, radius of earth is 6400 km.
65. Jupiter has a mass 318 times that of the earth, and its radius is 11.2 times the earth's radius. Estimate the escape velocity of a body from Jupiter's surface, given that the escape velocity from the earth's surface is 11.2 km s^{-1} .
66. The distance of Neptune and Saturn from the sun is nearly 10^{13} m and 10^{12} m respectively. Assuming that they move in circular orbits, then what will be the ratio of their periods.
67. Let the speed of the planet at perihelion P in fig be v_p and Sun planet distance SP be r_p . Relate (r_A, v_A) to the corresponding quantities at the aphelion (r_A, v_A) . Will the planet take equal times to traverse BAC and CPB ?

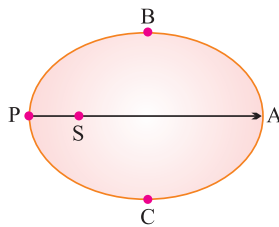

MULTIPLE CHOICE QUESTIONS

68. If both the mass and radius of the earth, each decreased by 50%, the acceleration due to gravity would
- (a) remains same (b) decreases by 50%
(c) decreases by 100% (d) increases by 100%
69. A body is suspended on a spring balance in a ship sailing along the equator with speed V . If w is the angular speed of the earth and w_0 is the scale reading when ship is at rest, the scale reading when the ship is sailing is
- (a) w_0 (b) zero
(c) $W_0 \left(1 \pm \frac{2wv}{g}\right)$ (d) $W_0 \left(1 - \frac{g}{2w}\right)$
70. The maximum vertical distance through which a full dressed astronaut can jump on the earth is 0.5m. Estimate the maximum vertical distance through which he can jump on the moon, which has mean density $\frac{2}{3}$ rd that of the earth and radius one quarter that of the earth
- (a) 1.5 m (b) 3 m
(c) 6 m (d) 7.5 m
71. A uniform ring of mass M and radius R is placed directly above a uniform sphere of mass $8M$ and same radius R . The centre of ring is at a distance of $d = \sqrt{3}R$ from the centre of sphere. The gravitational attraction between the sphere and ring is
- (a) $\frac{GM^2}{R^2}$ (b) $\frac{3GM^2}{R^3}$
(c) $\frac{2GM^2}{\sqrt{2}R^2}$ (d) $\frac{\sqrt{3}GM^2}{R^2}$
72. A satellite of mass m_s revolving in a circular orbit of radius r_s round the earth of mass M , has total energy E . Then it's angular momentum will be
- (a) $(2E m_s r_s)^{1/2}$ (b) $(2E m_s r_s)$
(c) $(2E m_s r_s^2)^{1/2}$ (d) $(2E m_s r_s^2)$
73. A mass M splits in to two parts m and $(M-m)$, which are separated by a certain distance. The ratio m/M which maximizes the gravitational force between the parts is
- (a) 1 : 4 (b) 1 : 3
(c) 1 : 2 (d) 1 : 1

74. If one moves from the surface of the earth to the moon, what will be the effect on it's weight
- Weight of the person decreases continuously with height from the surface of the earth
 - Weight of the person increases with height from the surface of earth
 - Weight of a person first decreases with height and then increases with height from surface of earth
 - Weight of person first increases with height and then decreases with height from the surface of earth
75. A satellites goes along an elliptical path around earth. The rate of change of area swept by the line joining earth and the satellite is proportional to
- $r^{1/2}$
 - r
 - $r^{3/2}$
 - r^2
76. The change in the value of 'g' at a height 'h' above the surface of the earth is same as at a depth 'd' below the surface of earth. When both 'd' and 'h' are much smaller than the radius of earth, then which one of the following in correct?
- $d = \frac{h}{2}$
 - $d = \frac{3h}{2}$
 - $d = 2h$
 - $d = h$
77. Two bodies of mass m and 4m are placed at a distance r. The gravitational potential at a point on the line joining them where the gravitational field is zero, is
- zero
 - $\frac{-4 Gm}{r}$
 - $\frac{-6 Gm}{r}$
 - $\frac{-9 Gm}{r}$
78. When a body is taken from poles to equator on the earth, its weight
- increases
 - decreases
 - remains same
 - increases at south pole and decreases at north pole

79. A man weights 60 kg at earth's surface. At what height above the earth's surface weight becomes 30 kg. Given radius of earth is 6400 km.
- (a) 2624 km (b) 3000 km
(c) 2020 km (d) None the these
80. There are two bodies of masses 1 kg and 100 kg reparated by a distance 1 m. At what distance from the smaller body, the intensity of gravitational field will be zero
- (a) $\frac{1}{9}$ m (b) $\frac{1}{10}$ m
(c) $\frac{1}{11}$ m (d) $\frac{10}{11}$ m
81. A particle falls towards earth from infinity. It's velocity on reaching the earth would be
- (a) infinity (b) $\sqrt{2gR}$
(c) $2\sqrt{gR}$ (d) zero
82. If g is the acceleration due to gravity on the earth's surface, the gain in potential energy of on object of mass m raised from the surface of earth to a height equal to radius R of the earth is
- (a) $\frac{1}{4} mgR$ (b) $\frac{1}{2} mgR$
(c) $2mgR$ (d) mgR
83. Energy required to move a satellite of mass m from an orbit of radius $2R$ to $3R$ is, (M mass of earth)
- (a) $\frac{GMm}{12 R^2}$ (b) $\frac{GMm}{3 R^2}$
(c) $\frac{GMm}{8 R}$ (d) $\frac{GMm}{6 R}$
84. If mass of a body is M on the surface of earth, then the mass of the same body on the moon surface is
- (a) $M/6$ (b) zero
(c) M (d) None of these

85. A body weighed 250N on the surface. Assuming the earth to be a sphere of uniform mass density, how much would it weigh half way down to the centre of earth
- (a) 240 N (b) 210 N
(c) 195 N (d) 125 N
86. If the earth stop moving around its polar axis, then what will be the effect on the weight of a body placed at the south pole?
- (a) Remains same (b) Increases
(c) Decreases but not zero (d) Decreases to zero

ASSERTION - REASON BASED QUESTIONS

Direction for Q.No. 1 to Q.No. 12

The following questions from 1 to 12 consists of two statements each, labelled as Assertion (A) and the other labelled as Reason (R). While answering these questions, you are required to choose any of the following from options (a), (b), (c) & (d).

- (a) If both A & R are true and R is the correct explanation of A.
(b) If both A & R are true but R is not the correct explanation of A.
(c) If A is true but R is false.
(d) If A is false and R is also false.
1. Assertion (A) : The time period of revolution of a satellite close to surface of earth is smaller than that revolving away from the surface of earth.
Reason (R) : The square of time period of revolution of a satellite is directly proportional to cube of its orbital radius.
2. Assertion (A) : We can not move even a finger without disturbing all the stars.
Reason (R) : Every body in this universe attracts every other body with a force which is inversely proportional to the square of distance between them.
3. Assertion (A) : Angular speed, linear speed and KE change with time but angular momentum remains constant for a planet orbiting the sun.
Reason (R) : Angular momentum is constant as no torque acts on the planet.

4. Assertion (A) : An artificial satellite moving in a circular orbit around the earth has a total energy (i.e. sum of potential & kinetic energy) E. Its potential energy $-E$.

Reason (R) : Potential energy of the body at a point in a gravitational field of earth is $\frac{-GMm}{2R}$.

5. Assertion (A) : The comets do not obey Kepler's Laws of planetary motion.

Reason (R) : The comets do not have elliptical orbits.

6. Assertion (A) : The square of the period of revolution of a planet is proportional to the cube of its distance from the sun.

Reason (R) : Sun's gravitational field is inversely proportional to the square of its distance from the planet.

7. Assertion (A) : The earth without its atmosphere would be inhospitably cold.

Reason (R) : All heat would escape in the absence of atmosphere.

8. Assertion (A) : The difference in the value of acceleration due to gravity at pole and equator is proportional to square of angular velocity of earth.

Reason (R) : The value of acceleration due to gravity is minimum at the equator and maximum at the pole.

9. Assertion (A) : At the centre of earth a body has centre of mass, but no centre of gravity.

Reason (R) : This is because $g = 0$ at the centre of the earth.

10. Assertion (A) : An astronaut in an orbiting space station above the earth experiences weightlessness.

Reason (R) : An object moving around the earth under the influence of earth's gravitational force is in a state of free fall.

11. Assertion (A) : Linear momentum of a planet does not remain conserved.

Reason (R) : Gravitational force acts on it.

12. Assertion (A) : Kepler's second law can be understood by conservation of angular momentum principle.

Reason (R) : Kepler's second law is related with areal velocity which can further be proved to be based on conservation of angular momentum as

$$\frac{dA}{dt} = \frac{1}{2} r^2 \omega.$$

CASE STUDY BASED QUESTIONS

1. Universal Law of Gravitation :-

Careful observations are the hallmarks of great discoveries and inventions. Isaac Newton observed that an apple fell from a tree towards the earth. This simple observation led him to propose an important law known as Newton Law of Gravitation. He proposed that all particles or objects in the universe attract each other as the earth attracts the apple.

Gravitation or gravitational force is the weakest of all the four basic forces in nature. Gravity is the special case of gravitation.

- (i) The force of gravitation is
- (a) repulsive (b) electro-state
(c) conservative (d) non-conservative
- (ii) The gravitational force between the two point masses does not depend upon
- (a) product of the two masses
(b) distance of separation between the two masses
(c) medium separating the two masses
(d) None the above
- (iii) The dimensional formula for 'G' universal gravitation constant is
- (a) $[M^{-1}L^3T^{-2}]$ (b) $[M^{-1}L^2T^{-2}]$
(c) $[M^{-1}L^3T^{-3}]$ (d) $[M^{-1}L^2T^{-3}]$
- (iv) strongest force among the following four forces is
- (a) electrostatic force (b) gravitational force
(c) nuclear force (d) magnetic force
- (v) Two spheres of masses m and M are situated in air and the gravitational force between them is F . The space around the masses is now filled with a liquid of relative density 3. The gravitational force will be
- (a) $3F$ (b) $\frac{F}{3}$ (c) F (d) $\frac{F}{9}$

2. Kepler's Law of Planetary Motion :-

To test the validity of Copernicus model (Heliocentric model), the great Danish astronomer Tycho Braho made extra-ordinary observations by studying the motions of planets and stars without the aid of telescope.

This data was critically analysed by Johannes Kepler. From these complicated data; Kepler deduced simple relations that governed planetary motion. These are three famous laws of Kepler which strongly supported the Copernicus model of solar system and played major role in the discovery of Newton's Law of Gravitation. The laws are (i) Law of orbits (ii) Law of areas (iii) Law of periods

(i) Kepler's second law is the consequence of the law of conservation of

- (a) linear momentum (b) energy
(c) angular momentum (d) mass

(ii) The distance of two planets from the sun are 10^{13}m & 10^{12}m respectively. The ratio of their time periods are

- (a) $10\sqrt{2}:1$ (b) $1:10\sqrt{9}$ (c) $1:1$ (d) $10^3:1$

(iii) The different positions of a planet around the sun in an elliptical orbit are shown by A, B & C. If v_1 , v_2 & v_3 be the tangential speeds of the planet at A, B & C respectively, then

- (a) $v_1 = v_2 = v_3$
(b) $v_1 > v_2 > v_3$
(c) $v_1 < v_2 < v_3$
(d) $v_1 = v_2 > v_3$

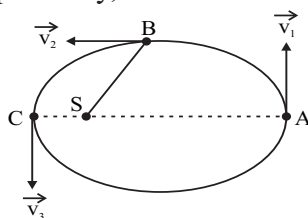

(iv) If the distance between the earth and the sun were one third of its present value, the number of days in a year would have been

- (a) increased (b) decreased
(c) remains same (d) cannot say

(v) A planet moves around the sun in an elliptical orbit with the sun at one of its foci. The physical quantity associated with the motion of the planet that remains constant with time is

- (a) velocity (b) centripetal force
(c) linear momentum (d) angular momentum

3. Acceleration due to gravity and its variation with altitude & depth :-

Relation between g and G : Where symbols have their usual meaning.

$$g = \frac{GM_e}{R_e^2} \quad \begin{array}{l} M_e = \text{Mass of the earth} \\ R_e = \text{Radius of the earth} \end{array}$$

This relation gives acceleration due to gravity at the surface of the earth.

The value g is independent of mass, size and shape of the body falling under gravity but g varies with altitude and depth & depends on shape of the earth and rotation of the earth.

- (i) Which of the following graph shows the correct variation of acceleration due to gravity with distance from the centre of the earth :

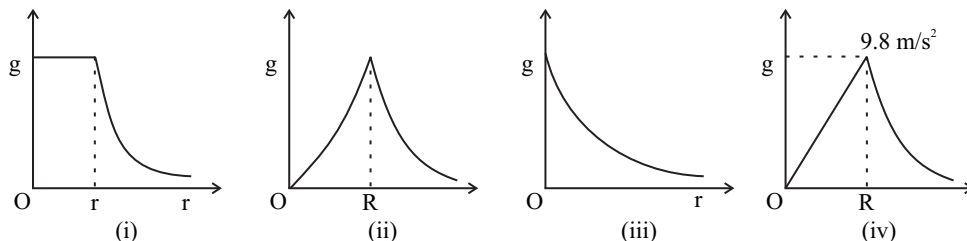

- (a) (i) (b) (ii) (c) (iii) (d) (iv)

- (ii) At which place, the weight of the body is maximum

- (a) at poles
 (b) equator
 (c) at the centre
 (d) at 1 km above the surface of the earth

- (iii) If the diameter of the earth becomes twice its present value but mass remaining the same, then the weight of the object would be

- (a) $\frac{W}{2}$ (b) $\frac{W}{4}$ (c) unaffected (d) $\frac{W}{\sqrt{2}}$

- (iv) The change in the value of g at a height h above the surface of the earth is same distance at a depth h below the surface of the earth. When both d & h are much smaller than the radius of the earth, then choose the correct answer

- (a) $d = \frac{h}{2}$ (b) $d = \frac{3h}{2}$ (c) $d = 2h$ (d) $d = h$

- (v) If the radius of two planets be R_1 & R_2 and their densities be ρ_1 & ρ_2 , then ratio of acceleration due to gravity on the planets will be

- (a) $R_1\rho_1 : R_2\rho_2$ (b) $R_1\rho_2 : R_2\rho_1$
 (c) 1 : 1 (d) $R_2\rho_1 : R_1\rho_1$

4. Escape Speed :-

If we throw a ball vertically upwards from the surface of the earth; it rises to a certain height and falls back. If we throw it with a greater velocity, it rises to a greater height. If we throw it with a sufficient velocity, it may

never come back. It will escape from the gravitational pull of the earth. This minimum velocity is called escape velocity.

- (i) Escape speed of a body of mass m depends upon its mass as
(a) m^0 (b) m (c) m^2 (d) m^3
- (ii) The escape velocity for an object projected vertically upward from the earth's surface is approx. 11 km/s. If the body is projected at an angle of 45° with the vertical, then escape velocity will be
(a) $11/\sqrt{2}$ km/s (b) 11 km/s (c) $11\sqrt{2}$ km/s (d) 22 km/s
- (iii) The value of escape velocity on a certain planet is 2 km/s. Then the value of orbital speed of a satellite orbiting close to its surface is
(a) 12 km/s (b) 1 km/s (c) $\sqrt{2}$ km/s (d) $2\sqrt{2}$ km/s
- (iv) The escape speed of the planet is v . If the radius of the planet contracts to $\frac{1}{4}$ th of present value, without any change in mass, the escape speed would become
(a) halved (b) doubled (c) quadrupled (d) one fourth
- (v) The moon has no atmosphere as
(a) The escape speed on the moon is very large as the thermal speed of the molecules of gases on moon.
(b) The escape speed on the moon is equal to the thermal speed of the gaseous molecules on the moon.
(c) The escape speed on the moon is very small as compared to the thermal speed of the molecules of gases on moon.
(d) Size of the moon as compared to the earth is very less and hence escape speed of moon is large.

5. Satellite :-

A small body revolving around a planet in an orbit is called its satellite. To put the satellite with a particular orbit around the earth, we need to give it two velocities. A minimum vertical velocity to take the satellite to a suitable height for which multistage rockets are used and secondly when satellite is reached at a particular height it is given a horizontal velocity called orbital velocity.

Geostationary satellite are used for communication purposes and polar satellite are used for spying and remote sensing.

- (i) Time period of earth's satellite in circular orbit is independent of
- (a) mass of the satellite
 - (b) radius of the orbit
 - (c) both the mass and radius of the orbit
 - (d) neither the mass of the satellite nor the radius of the orbit
- (ii) The time period of a satellite of the earth is 5 hrs. If the separation between the earth & satellite is increased to 4 time the previous value, the new time period will become
- (a) 10 hrs. (b) 80 hrs. (c) 40 hrs. (d) 20 hrs.
- (iii) If suddenly the gravitational force of attraction between the earth and a satellite revolving around it becomes zero, then the satellite will
- (a) continue to move in its orbit with the same velocity
 - (b) move tangentially to the original orbit with the same velocity
 - (c) become stationary in its orbit
 - (d) move towards the earth
- (iv) The total energy of a satellite is E . What is its potential energy?
- (a) $2E$ (b) $-2E$ (c) E (d) $-E$
- (v) A synchronous relay satellite reflects TV signals and transmits TV program from one part of the world to the other because its
- (a) period of revolution is greater than the period of rotation of the earth about its axis.
 - (b) Period of revolution is less than the period of rotation of the earth about its axis.
 - (c) Period of revolution is equal to the period of rotation of the earth about its axis.
 - (d) mass is less than the mass of the earth.

Answers For Very Short Questions (1 Mark)

1. Both forces will be equal in magnitude as gravitational force is a mutual force between the two bodies.
2. When moving in a merry go round, our weight appears to decrease when we move down and increases when we move up, this change in weight makes us feel giddy.
3. (i) Value of acceleration due to gravity
(ii) Surface temperature of planet.

4. $\therefore F = \frac{GMm}{R^2}$, $F \propto m$ but $g = \frac{GM}{R^2}$ and does not depend on 'm' hence they bodies fall with same 'g'.
5. No, the gravitational force is independent of intervening medium.
6. $F = 1 F' = \frac{F}{4} = \frac{1}{4} N$.
7. Mass does not change, weight at centre of earth will be 0 because $g = 0$.
8. Because it arises due to attractive force of gravitation.
9. $v_e = \sqrt{2} v_0$, $\therefore v_e = \sqrt{\frac{2GM}{R}}$ and $v_0 = \sqrt{\frac{GM}{R}}$ when $r = R$.
10. $T = \frac{2\pi r}{v}$ and $v = \sqrt{\frac{Gm}{r}}$, T is independent of mass, $\frac{T_B}{T_A} = 1 : 1 \Rightarrow T_A = T_B$.
11. Sun should be at B as speed of planet is greater when it is closer to sun.
12. The gravitational force between satellite and earth provides the necessary centripetal force for the satellite to orbit the earth.
13. The speed of satellite during descent is much larger than during ascent, and so heat produced is large.
14. No, A satellite will be always visible only if it revolves in the equatorial plane, but New Delhi does not lie in the region of equatorial plane.
15. 'g' gets doubled as $g \propto \rho$ (density).
16. As $g = GM/R^2$ and the value of R at the poles is less than that the equator, so g at poles is greater than that g at the equator. Now, $g_p > g_e$, hence $mg_p > mg_e$ i.e., the weight of a body at the poles is more than the weight at the equator.
17. The astronaut is in the gravitational field of the earth and experiences gravity. However, the gravity is used in providing necessary centripetal force, so is in a state of free fall towards the earth.
18. Geostationary satellite are used for telecommunication and polars satellite for remote sensing.
19. Angular velocity of binary stars are same is $\omega_A = \omega_B$,

$$\frac{2\pi}{T_A} = \frac{2\pi}{T_B} \Rightarrow T_A = T_B$$

$$20. \frac{T_2^2}{T_1^2} = \left(\frac{R_2}{R_1} \right)^3 \Rightarrow T_2^2 = 64 \times 25 \Rightarrow 40 \text{ hr.}$$

21. The force of gravitation exerted by the earth on a body of mass m is

$$F = G \frac{Mm}{R^2} = mg$$

$$\text{Acceleration imparted to the body, } g = \frac{Gm}{R^2}$$

Clearly, g does not depend on m . Hence the earth imparts same acceleration to all bodies.

22. The satellite will move tangentially to the original orbit with a velocity with which it was revolving.

Short Answers (2 Marks)

$$23. g = \frac{GM}{R^2} \text{ if } R \text{ decreases by } 1\% \text{ it becomes } \frac{99}{100}R$$

$$g' = \frac{GM}{(.99R)^2} = 1.02 \frac{GM}{R^2} = (1 + 0.02) \frac{GM}{R^2}$$

$$\therefore g' \text{ increases by } 0.02 \frac{GM}{R^2}, \text{ therefore increases by } 2\%.$$

24. (b), (c) and (d) are affected in space.

25. The maximum orbital velocity of a satellite orbiting near its surface is

$$v_0 = \sqrt{gR} = \frac{v_e}{\sqrt{2}}$$

For the satellite to escape gravitational pull the velocity must become v_e

$$\text{But } v_e = \sqrt{2}v_0 = 1.414v_0 = (1 + 0.414)v_0$$

This means that it has to increase 0.414 in 1 or 41.4%.

\therefore The minimum increment is required, as the velocity of satellite is maximum when it is near the earth.

26. Here

$$g = \frac{GM}{R^2} = \frac{G}{R^2} \cdot \frac{4}{3} \pi R^3 \rho$$

or $g \propto R\rho$

$\therefore \frac{g_1}{g_2} = \frac{R\rho}{2R \cdot \frac{\rho}{2}} = 1:1.$

27. $v_e = \sqrt{\frac{2GM}{R_e}}, v_p = \frac{\sqrt{2GM_p}}{R_p}$

$M_p = \frac{M}{9}, R_p = \frac{R_e}{4}$

$\therefore v_p = \sqrt{2G \frac{M}{9} \times \frac{4}{R_e}}$
 $= \frac{2}{3} \sqrt{\frac{2GM}{R_e}} = \frac{2}{3} \times 11.2 = \frac{22.4}{3}$
 $= 7.47 \text{ km/sec.}$

28. $g' = 64\% \text{ of } g = \frac{64}{100} g$

$g' = g \frac{R^2}{(R+h)^2} = \frac{64}{100} g$

$\therefore \frac{R}{R+h} = \frac{8}{10}$

$h = \frac{R}{4} = 1600 \text{ km.}$

29. $g_d = g_h$

$g \left(1 - \frac{d}{R}\right) = g \left(1 - \frac{2h}{R}\right)$

$d = 2h = 2 \times 40 = 80 \text{ km.}$

30. $R = 1.5 \times 10^8 \text{ km} = 1.5 \times 10^{11} \text{ m}$

$T = 365 \text{ days} = 365 \times 24 \times 3600 \text{ s}$

Centripetal force = gravitational force

$$\frac{Mv^2}{R} = \frac{GMm}{R^2} = \frac{m \left(\frac{2\pi R}{T} \right)^2}{R} = \frac{GMm}{R^2}$$

$$M_s = \frac{4\pi^2 R^3}{GT^2}$$

$$= \frac{4 \times 9.87 \times (1.5 \times 10^{11})^3}{6.64 \times 10^{-11} \times (365 \times 24 \times 3600)^2}$$

$$M_s = 2.01 \times 10^{30} \text{ g.}$$

31. $g \propto \frac{1}{r^2}$ for $r > 0$ above surface of earth *i.e.*, AB

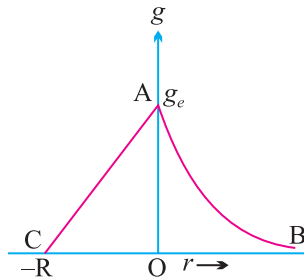

$g \propto (R - d)$ for $r < 0$ below surface of earth *i.e.*, AC

g is max. for $r = 0$ on surface.

32. Given $M_s = 2 \times 10^{30}$ kg,

$$M_e = 6 \times 10^{24} \text{ kg, } r = 1.5 \times 10^{11} \text{ m}$$

Let m be the mass of the rocket. Let at distance x from the earth, the gravitational force on the rocket be zero.

Then at this distance, Gravitational pull of the earth on the rocket

= Gravitational pull of the sun on the rocket.

$$\text{i.e., } \frac{GM_e m}{x^2} = \frac{GM_s m}{(r-x)^2} \text{ or } \frac{(r-x)^2}{x^2} = \frac{M_s}{M_e}$$

$$\text{or } \frac{R-x}{x} = \sqrt{\frac{M_s}{M_e}} = \sqrt{\frac{2 \times 10^{30}}{6 \times 10^{24}}} = \frac{10^3}{\sqrt{3}} = 577.35$$

$$\text{or } r-x = 577.35x$$

or $578.35 x = r = 1.5 \times 10^{11}$

or $x = \frac{1.5 \times 10^{11}}{578.35} = 2.59 \times 10^8 \text{ m.}$

33. $T_1 = 365 \text{ days; } r_1 = r, T_2 = ?, r_2 = r/2$

$$\frac{T_2^2}{T_1^2} = \frac{r_2^3}{r_1^3}$$

or
$$T_2 = T_1 \cdot \left[\frac{r_2}{r_1} \right]^{3/2}$$

$$= 365 \left[\frac{r/2}{r} \right]^{3/2} = 129 \text{ days}$$

Therefore decrease in number of days in one year will be
 $= 365 - 129 = 236 \text{ days.}$

34. Here $mg = 63 \text{ N, } h = R/2$

As
$$\frac{g_h}{g} = \left(\frac{R}{R+h} \right)^2 = \left(\frac{R}{R + \frac{R}{2}} \right)^2 = \left(\frac{2}{3} \right)^2 = \frac{4}{9}$$

$$g_h = \frac{4}{9} g$$

$\therefore mg_h = \frac{4}{9} mg = \frac{4}{9} \times 63 = 28 \text{ N.}$

35. Since the earth revolves from west to east, so when the rocket is launched from west to east the relative velocity of the rocket increases which helps it to rise without much consumption of fuel.

36. The value of 'g' on hills is less than at the plane, so the weight of tennis ball on the hills is lesser force than at planes that is why the earth attract the ball on hills with lesser force than at planes. Hence the ball bounces higher.

37. The tidal effect depends inversely on the cube of the distance, while gravitational force depends on the square of the distance.

38.

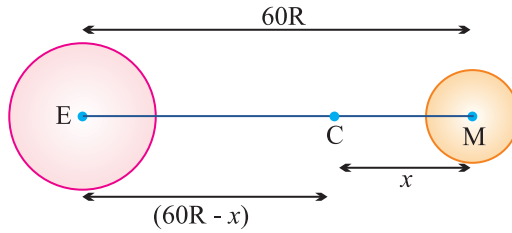

Gravitational field at C due to earth

= Gravitational field at C due to earth moon

$$\frac{GM}{(60R - x)^2} = \frac{GM/81}{x^2}$$

$$81x^2 = (60R - x)^2$$

$$9x = 60R - x$$

$$x = 6R.$$

39. According to Kepler's IInd law, area velocity for the planet is constant

$$\therefore \frac{A_1}{t_1} = \frac{A_2}{t_2}, A_1 = 2A_2$$

$$\therefore \frac{2A_2}{t_1} = \frac{A_2}{t_2}$$

$$t_1 = 2t_2.$$

40. Gravitational P.E. of mass m in orbit of radius $R = U = -\frac{GMm}{R}$

$$\therefore U_i = -\frac{GMm}{2R}$$

$$U_f = -\frac{GMm}{3R}$$

$$\Delta U = U_f - U_i = GMm \left[\frac{1}{2} - \frac{1}{3} \right]$$

$$= \frac{GMm}{6R}$$

41.

$$g = \frac{4}{3} \pi GR \rho$$

$$g' = \frac{4}{3} \pi GR'g'$$

The gain in P.E. at the highest point will be same in both cases. Hence

$$mg'h' = mgh$$

$$h' = \frac{mgh}{mg'} = \frac{m \times \frac{4}{3} \pi GRgh}{m \times \frac{4}{3} \pi GR^1g^1}$$

$$h' = \frac{3 \times 4 \times R \times g \times 1.5}{Rg}$$

$$h' = 18 \text{ m.}$$

Answers For 3 Marks Questions

44.

$$E_1 = \frac{GM}{(OA)^2}$$

$$E_2 = \frac{GM}{(OB)^2}$$

$$E_3 = \frac{GM}{(OC)^2}$$

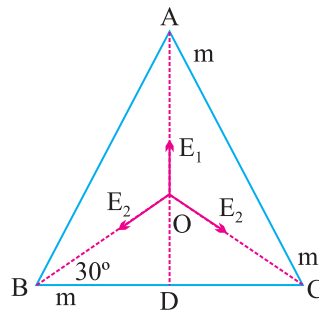

From ΔODB ,

$$\cos 30^\circ = \frac{BD}{OB} = \frac{l/2}{OB}$$

$$OB = \frac{l/2}{\cos 30^\circ} = \frac{BD}{\cos 30^\circ} = \frac{l/2}{\frac{\sqrt{3}}{2}} = l/\sqrt{3}$$

Gravitational field at O due to m at A, B and C is say \vec{E}_1, \vec{E}_2 and \vec{E}_3

$$\begin{aligned}
 E &= \sqrt{E_2^2 + E_3^2 + 2E_2E_3 \cos 120^\circ} \\
 &= \sqrt{\frac{(GM3)^2}{I^2} + \left(\frac{3Gm}{I}\right)^2 + 2\left(\frac{3GM}{I}\right)\left(-\frac{1}{2}\right)} \\
 &= \frac{3GM}{I} = \text{along OD}
 \end{aligned}$$

\vec{E} is equal and opposite to \vec{E}_1

\therefore net gravitational field = zero

As gravitational potential is scalar

$$\begin{aligned}
 V &= V_1 + V_2 + V_3 \\
 &= \frac{GM}{OA} - \frac{GM}{OB} - \frac{GM}{OC} \\
 V &= -\frac{3GM}{I/\sqrt{3}} = -3\sqrt{3} \frac{Gm}{I}.
 \end{aligned}$$

46. Work done on satellite in first stage = $W_1 = \text{PE at 150 km} - \text{PE at the surface}$

$$\begin{aligned}
 W_1 &= \frac{GMm}{R+h} - \left(-\frac{GMm}{R}\right) \\
 &= \frac{GMmh}{R(R+h)} \quad \boxed{}
 \end{aligned}$$

Work done on satellite in 2nd stage = W_2

= energy required to give orbital velocity v_0

$$= \frac{1}{2}mv_0^2 = \frac{1}{2}\left(\frac{GMm}{R+h}\right)$$

$$\frac{W_1}{W_2} = \frac{2h}{R} = \frac{2 \times 150}{6400} = \frac{3}{64} < 1$$

$W_2 > W_1$, so second stage requires more energy.

47. $V_e = 11.2 \text{ kms}^{-1}$, velocity of projection = $v = 3v_e$ Let m be the mass of projectile and v_0 the velocity after it escapes gravitational pull.

By law of conservation of energy

$$\frac{1}{2}mv^2 = \frac{1}{2}mv_e^2 + \frac{1}{2}mv_0^2$$

$$v_0 = \sqrt{v^2 - v_e^2} = \sqrt{9v_e^2 - v_e^2} = \sqrt{8v_e^2}$$

$$v_0 = 22.4\sqrt{2}$$

$$v_0 = 31.68 \text{ km s}^{-1}.$$

48. The energy required to pull the satellite from earth influence should be equal to the total energy with which it is revolving around the earth.

$$\text{The K.E. of satellite} = \frac{1}{2}mv^2 = \frac{1}{2}m \frac{GM}{R+h}, \therefore v = \sqrt{\frac{GM}{R+h}}$$

$$\text{The P.E. of satellite} = -\frac{GMm}{R+h}$$

$$\therefore \text{T.E.} = \frac{1}{2} \frac{mGM}{(R+h)} - \frac{GMm}{(R+h)} = -\frac{1}{2} \frac{GMm}{(R+h)}$$

$$\therefore \text{Energy required will be} \left(+\frac{1}{2} \frac{GMm}{(R+h)} \right).$$

$$51. E_1 = -\frac{GMm}{R} = -\frac{mgR^2}{R} = -mgR$$

If v is velocity of the satellite at distance $2R$, then total energy

$$\begin{aligned} E_2 &= \text{K.E.} + \text{P.E.} \\ &= \frac{1}{2}mv^2 - \frac{GMm}{(2R+R)} \end{aligned}$$

$$\text{Orbital velocity of satellite, } v = \sqrt{\frac{GM}{2R+R}} \text{ or } v^2 = \frac{GM}{3R}$$

$$\text{So, } \frac{1}{2}mv^2 = \frac{GMm}{6R}$$

$$E_2 = \frac{GMm}{6R} - \frac{GMm}{3R} = -\frac{GMm}{6R} = -\frac{mgR}{6}$$

Minimum energy required to launch the satellite is

$$= E_2 - E_1 = -\frac{1}{6}mgR + mgR = \frac{5}{6}mgR.$$

Answers For Numericals

58.
$$F = \frac{GMm}{r^2}$$

$$= \frac{6.67 \times 10^{-11} \times 1.99 \times 10^{30} \times 1.9 \times 10^{27}}{(7.8 \times 10^{11})^2}$$

$$F = 4.1 \times 10^{23} \text{ N}$$

\therefore
$$F = \frac{mv^2}{r}$$

$$v = \sqrt{\frac{Fr}{m}} = \sqrt{\frac{GMm}{r^2} \times \frac{r}{m}}$$

$$v = \sqrt{\frac{Gm}{r}} = \sqrt{\frac{6.67 \times 10^{-11} \times 1.9 \times 10^{30}}{7.8 \times 10^{11}}}$$

$$v = 1.3 \times 10^4 \text{ ms}^{-1}.$$

59. Let $m_1 = m$ then $m_2 = M - m$

Force between them when they are separated by distance 'r'

$$F = \frac{Gm(M-m)}{r^2} = \frac{G}{r^2}(Mm - m^2)$$

For F to be maximum, differentiate F w.r.t. m and equate to zero

$$\frac{dF}{dm} = \frac{G}{r^2}(M - 2m) = 0$$

$$M = 2m; m = \frac{M}{2}$$

\therefore
$$m_1 = m_2 = \frac{M}{2}.$$

60.
$$g = \frac{GM}{R^2}$$

Taking logarithm $\log g = \log G + \log M - 2 \log R$

Differentiating it

$$\frac{dg}{g} = 0 + 0 - 2 \frac{dR}{R} = -2 \frac{dR}{R} = -2 \left[\frac{-2}{100} \right]$$

$$\frac{dg}{g} \times 100 = -2 \left[\frac{-2}{100} \right] \times 100 = 4\%$$

61. Total Energy of the body = KE + PE = $0 + \left[-\frac{GMm}{r^2} \right] = -\frac{mgR^2}{r}$

Let v be velocity acquired by body on reaching the surface of earth.

$$\text{Total Energy on the surface} = \frac{1}{2}mv^2 + \left[-\frac{mgR^2}{R} \right] = \frac{1}{2}mv^2 - mgR$$

According to law of conservatives of energy

$$\frac{1}{2}mv^2 - mgR = \frac{mgR^2}{r}$$

$$v^2 = 2gR - \frac{2gR^2}{r} = 2gR^2 \left[\frac{1}{R} - \frac{1}{r} \right]$$

$$\Rightarrow v = R \sqrt{2g \left(\frac{1}{R} - \frac{1}{r} \right)}$$

62. $g' = 4\%$ of $g = \frac{4}{100} \cdot g$

$$\frac{4}{100}g = g \left[\frac{R}{R+h} \right]^2$$

$$\frac{2}{10} = \frac{R}{R+h}$$

$$\therefore h = 4R = 4 \times 6400 = 25,600 \text{ km.}$$

63. Gravitational intensity = $E = \frac{GM}{R^2}$

$$\text{Gravitational potential } V = -\frac{GM}{R}$$

$$\therefore \frac{V}{E} = -R$$

$$\text{or } V = -E \times R$$

$$\text{or } V = -4.8 \times 10,000 \times 10^3 = -4.8 \times 10^7 \text{ J kg}^{-1}.$$

$$64. \quad U = \text{Potential at height } h = -\frac{GM}{R+h}$$

$$U = \frac{6.67 \times 10^{-11} \times 6 \times 10^{24}}{6.4 \times 10^6 + 36 \times 10^6} = -9.44 \times 10^6 \text{ J/kg}$$

65. Escape velocity from the earth's surface is

$$v_e = \sqrt{\frac{2GM}{R}} = 11.2 \text{ kms}^{-1}$$

Escape velocity from Jupiter's surface will be

$$v_e' = \sqrt{\frac{2GM'}{R'}}$$

But $M' = 318 M$, $R' = 11.2 R$

$$\begin{aligned} \therefore v_e' &= \sqrt{\frac{2G(318M)}{11.2}} = \sqrt{\frac{2GM}{R} \times \frac{318}{11.2}} \\ &= v_e' \times \sqrt{\frac{318}{11.2}} = 11.2 \times \sqrt{\frac{318}{11.2}} = 59.7 \text{ kms}^{-1}. \end{aligned}$$

66. By Kepler's IIIrd law

$$\left(\frac{T_n}{T_s}\right)^2 = \left(\frac{R_n}{R_s}\right)^3$$

$$\begin{aligned} \frac{T_n}{T_s} &= \left(\frac{R_n}{R_s}\right)^{3/2} = \left(\frac{10^{13}}{10^{12}}\right)^{3/2} = 10^{3/2} \\ &= 10\sqrt{10} = 10 \times 3.16 = 31.6 \end{aligned}$$

\therefore

$$\boxed{T_N : T_S = 31.6 : 1.}$$

67. The magnitude of angular momentum at P is $L_P = m_P r_P v_P$

Similarly magnitude of angular momentum at A is $L_A = m_A r_A v_A$

From conservation of angular momentum

$$m_P r_P v_P = m_A r_A v_A$$

$$\frac{v_P}{v_A} = \frac{r_A}{r_P}$$

$$\therefore r_A > r_P, \therefore v_P > v_A$$

area bound by SB and SC (SBAC > SBPC)

\therefore By 2nd law equal areas are swept in equal intervals of time. Time taken to transverse BAC > time taken to transverse CPB.

Answer (MCQ) Key :

68. (d) 69. (c) 70. (b) 71. (d) 72. (c) 73. (c)
 74. (c) 75. (a) 76. (c) 77. (a) 78. (d) 79. (b)
 80. (d) 81. (c) 82. (b) 83. (b) 84. (d) 85. (c)
 86. (d) 87. (a)

HINTS AND SOLUTION (MCQ)

68. (d) $g = \frac{GM}{R^2}$ and $g^1 = \frac{G(M/2)}{\left(\frac{R}{2}\right)^2} = 2g$

$$\% \text{ increasing} = \frac{\Delta g}{g} \times 100 = \left(\frac{2g - g}{g}\right) \times 100 = 100\%$$

69. (c) At equator, $g_1 = g \left[1 - \frac{w^2 R}{g}\right] = g - w^2 R$

$$w_0 = m g_1 = m(g - w^2 R) = m \left[g - \frac{v^2 R}{R} \right]$$

Speed of ship relative to the velocity of centre of earth be $V_0 \pm V$.

$$\text{Weight on spring balance, } W = m \left[g - \frac{(V_0 \pm v)^2}{R} \right]$$

$$\frac{w}{w_0} = \left[1 - \frac{(v_0 \pm v)^2}{Rg} \right] \left[1 - \frac{v^2}{Rg} \right]^{-1}$$

$$w = w_0 \left[1 \pm \frac{2wv}{g} \right]$$

70. (b) On the moon, $g_m = \frac{4}{3} \pi G \left(\frac{R}{4} \right) \left(\frac{2e}{3} \right) = \frac{g}{6}$

Work done in jumping = $m \times g \times 0.5 = m \times \frac{g}{6} \times h_1$

$h_1 = 3.0\text{m}$

71. (d) Gravitational intensity due to ring at a distance $d = \sqrt{3}R$, on its axis

is $I = \frac{GMd}{(d^2 + R^2)^{3/2}} = \frac{\sqrt{3}GM}{8R^2}$

Force on sphere = $8m \times I = \frac{\sqrt{3}GM^2}{R^2}$

72. (c) Total energy of satellite, $E = \frac{-GMm_s}{2r_s}$

Orbital velocity, $v_s = \sqrt{\frac{GM}{r_s}}$

$L = m_s v_s r_s = (2E m_s r_s^2)^{1/2}$

73. (c) $F = \frac{GM(M-m)}{x^2}$ For maximum, $\frac{dF}{dm} = 0$

$\frac{dF}{dm} = \frac{G}{x^2} (M - 2m) = 0 \Rightarrow \frac{m}{M} = \frac{1}{2}$

74. (c) First decreases, becomes zero and then increases again.

75. (a) A real velocity = $\frac{dA}{dt} = \frac{L}{2m} = \frac{mVr}{2m} = \frac{Vr}{2}$

$= \frac{r}{2} \sqrt{\frac{GM}{r}} = \frac{1}{2} \sqrt{GMr}$

So, $\frac{dA}{dt} \propto \sqrt{r}$

76. (c) $g_n = g_d$

$$g\left(1 - \frac{2h}{R}\right) = g\left(1 - \frac{d}{R}\right) \quad \therefore d = 2h.$$

77. (d) Position of null point from mass m , $x = \frac{r}{1 + \sqrt{\frac{4m}{m}}} = \frac{r}{3}$

$$\text{Gravitational potential at null point} = -\frac{GM}{\frac{r}{3}} - \frac{G \cdot 4m}{\frac{2r}{3}} = -\frac{9GM}{r}.$$

78. (b) $g_p = g$, $g_e = g - \omega^2 R < g_p$

79. (d) $mg^1 = \frac{mgR^2}{(R+h)^2} \Rightarrow 30 = \frac{60 \times 6400^2}{(6400+h)^2}$
 $\Rightarrow h = 2651 \text{ km}$

80. (c) $\frac{G \times 1}{x^2} = \frac{G \times 100}{(1-x)^2} \Rightarrow x = \frac{1}{11} \text{ m}$

81. (b) $\frac{1}{2}mv^2 = U_i - U_f = 0 - \frac{(-GMm)}{R}$
 $v = \sqrt{2gR}$

82. (b) On earth's surface, $U_1 = -\frac{GMm}{R}$

At a height equal to radius of earth,

$$U_2 = -\frac{GMm}{R+r} = -\frac{GMm}{2R}$$

$$\Delta U = U_2 - U_1 = -\frac{GMm}{2R} + \frac{GMm}{R} = \frac{GMm}{2R}$$

$$\text{But } g = \frac{GM}{R^2} \Rightarrow \Delta U = \frac{gR^2 m}{2R} = \frac{mgR}{2}$$

83. (d) Gravitational P.E. of mass m in an orbit of radius R

$$U = \frac{-GMm}{R} \quad \therefore U_i = \frac{-GMm}{2R}, \quad U_f = \frac{-GMm}{3R}$$

$$\Delta U = U_f - U_i = \frac{GMm}{6R}.$$

84. (c) Mass does not change.

85. (d) At depth, $d = \frac{R}{2}$,

$$g_d = g \left(1 - \frac{d}{R} \right) = \frac{g}{2}$$

$$\text{Net weight} = \frac{mg}{2} = 125 \text{ N}$$

86. (a) At poles $\lambda = 90^\circ$, so,

$$g_{\text{pole}} = g - \omega^2 R \cos^2 \lambda = g.$$

ASSERTION - REASON BASED ANSWERS

1. (a) A & R both are true and R is the correct explanation of A.
2. (a) A & R both are true and R is the correct explanation of A.
3. (a) A & R both are true and R is the correct explanation of A.

4. (d) A & R both are false. $E = \frac{-GMm}{2(R+h)}$

$$PE = \frac{-GMM}{(R+h)}$$

5. (b) A & R both are true, but R is not the correct explanation of A. Some of the comets are non-periodic and move along hyperbolic or parabolic paths. They don't obey Kepler's law of planetary motion.
6. (b) both A & R are true and R is not the correct explanation of A.

$$\begin{aligned} \frac{GMm}{r^2} &= \frac{mv^2}{r} \\ \Rightarrow \frac{GMm}{r^2} &= \frac{m}{r} \left(\frac{2\pi r}{T} \right)^2 \\ \Rightarrow T^2 &= \left(\frac{4\pi^2}{GM} \right) r^3 \quad \Rightarrow T^2 \propto r^3 \end{aligned}$$

7. (a) both A & R are true and R is the correct explanation of A.
 8. (a) both A & R are true and R is the correct explanation of A.
 $(g_p - g_e) = R_e \omega^2$
 9. (a) both A & R are true and R is the correct explanation of A.
 10. (a)
 11. (a)
 12. (a)

CASE STUDY BASED ANSWERS

1. i. (c) conservative
 ii. (c) Medium separating the two masses
 iii. (a) $[M^{-1} L^3 T^{-2}]$
 iv. (c) Nuclear force
 v. (c) F
2. i. (c) angular momentum
 ii. (a) $10\sqrt{2} : 1$ use $\frac{T_1}{T_2} = \left[\frac{r_1}{r_2} \right]^{3/2}$
 iii. (c) $v_1 < v_2 < v_3$ as $L = mvr = \text{constant}$
 $\Rightarrow v \propto \frac{1}{r}$
 iv. (b) decreased as $T^2 \propto (R)^3$
 v. (d) angular momentum
3. i. (d) (iv)
 ii. (a) At poles
 iii. (b) $\frac{W}{4}$ use $g = \frac{GM}{R^2}$
 iv. (c) $d = 2h$ Put $\left(1 - \frac{2h}{R}\right) = 1 - \frac{d}{R}$ as $g_n = g_d$.
 v. (a) $R_1 \rho_1 : R_2 \rho_2$ [Use $g = \frac{4}{3} \rho G R \rho$.]

4. i. (a) m^0
ii. (b) 11 km/s
iii. (d) $2\sqrt{2}$ km/s
iv. (a) halved
v. (c)
5. i. (a) mass of the satellite
ii. (c) 40 hrs. Hint : $\left(\frac{T_1}{T_2}\right)^2 = \left(\frac{R_1}{R_2}\right)^3$
iii. (b)
iv. (a) $E = \frac{-GMm}{2r}$, P.E. = $\frac{-GMm}{r}$ so PE = 2E
v. (c)

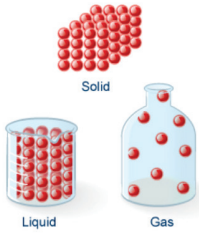

Unit - 7

Properties Of Matter

7.1 Interatomic Forces

The forces between the atoms due to electrostatic interaction between the charges of the atoms are called interatomic forces.

- (1) When two atoms are brought close to each other to a distance of the order of $10^{-10} m$, attractive interatomic force is produced between two atoms.
- (2) This attractive force increases continuously with decrease in r and becomes maximum for one value of r called critical distance, represented by X (as shown in the figure).
- (3) When the distance between the two atoms becomes r_0 , the interatomic force will be zero. This distance r_0 is called normal or equilibrium distance.

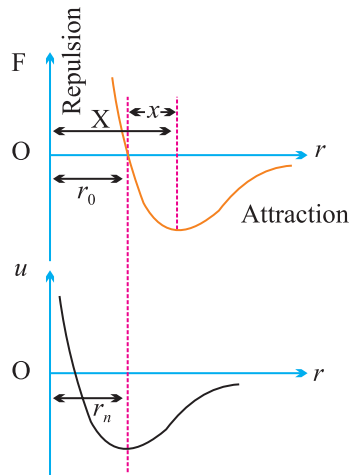

- (4) When the distance between the two atoms further decreased, the interatomic force becomes repulsive in nature and increases very rapidly.

- (5) The potential energy U is related with the interatomic force F by the following relation.

$$F = \frac{-dU}{dr}$$

When the distance between the two atoms becomes r_0 , the potential energy of the system of two atoms becomes minimum (*i.e.*, attains maximum negative value hence the two atoms at separation r_0 will be in a state of equilibrium.

7.2 Intermolecular Forces

The forces between the molecules due to electrostatic interaction between the charges of the molecules are called intermolecular forces. These forces are also called Vander Waal forces and are quite weak as compared to interatomic forces.

7.3 Solids

A solid is that state of matter in which its constituent atoms or molecules are held strongly at the position of minimum potential energy and it has a definite shape and volume.

7.4 Elastic Property of Matter

- (1) **Elasticity** : The property of matter by virtue of which a body tends to regain its original shape and size after the removal of deforming force is called elasticity.
- (2) **Plasticity** : The property of matter by virtue of which it does not regain its original shape and size after the removal of deforming force is called plasticity.
- (3) **Perfectly elastic body** : If on the removal of deforming forces the body regain its original configuration completely it is said to be perfectly elastic.

A quartz fibre and phosphor is the nearest approach to the perfectly elastic body.

- (4) **Perfectly plastic body** : If the body does not have any tendency to recover its original configuration on the removal of deforming force, it is said to be perfectly plastic.

Paraffin wax, wet clay are the nearest approach to the perfectly plastic body. Practically there is no material which is either perfectly elastic or perfectly plastic.

- (5) **Reason of elasticity** : On applying the deforming forces, restoring forces are developed. When the deforming force is removed, these restoring

forces bring the molecules of the solid to their respective equilibrium position ($r = r_0$) and hence the body regains its original form.

- (6) **Elastic limit** : The maximum deforming force upto which a body retains its property of elasticity is called elastic limit of the material of body.

Elastic limit is the property of a body whereas elasticity is the property of material of the body.

- (7) **Elastic fatigue** : The temporary loss of elastic properties because of the action of repeated alternating deforming force is called elastic fatigue.

It is due to this reason :

- (i) Bridges are declared unsafe after a long time of their use.
 - (ii) Spring balances show wrong readings after they have been used for a long time.
 - (iii) We are able to break the wire by repeated bending.
- (8) **Elastic after effect** : The time delay in which the substance regains its original condition after the removal of deforming force is called elastic after effect. It is negligible for perfectly elastic substance, like quartz, phosphor bronze and large for glass fibre.

7.5 Stress

The internal restoring force acting per unit area of cross section of the deformed body is called stress.

$$\text{Stress} = \frac{\text{Force}}{\text{Area}} = \frac{F}{A}$$

Unit : N/m^2 (S.I.), dyne/cm^2 (C.G.S.)

Stress developed in a body depends upon how the external forces are applied over it.

On this basis there are two types of stresses : Normal and Shear or tangential stress

- (1) **Normal stress** : Here the force is applied normal to the surface.

It is again of two types : Longitudinal and Bulk or volume stress.

- (i) Longitudinal stress
 - (a) Deforming force is applied parallel to the length and causes increase in length.

- (b) Area taken for calculation of stress is area of cross section.
 - (c) Longitudinal stress produced due to increase in length of a body under a deforming force is called tensile stress.
 - (d) Longitudinal stress produced due to decrease in length of a body under a deforming force is called compressional stress.
- (ii) Bulk or Volume stress
- (a) It occurs in solids, liquids or gases.
 - (b) Deforming force is applied normal to surface at all points.
 - (c) It is equal to change in pressure because change in pressure is responsible for change in volume.
- (2) **Shear or tangential stress** : It comes in picture when successive layers of solid move on each other *i.e.*, when there is a relative displacement between various layers of solid.
- (i) Here deforming force is applied tangential to one of the faces.
 - (ii) Area for calculation is the area of the face on which force is applied.
 - (iii) It produces change in shape, volume remaining the same.

7.6 Strain

The ratio of change in configuration to the original configuration is called strain. It has no dimensions and units. Strain are of three types :

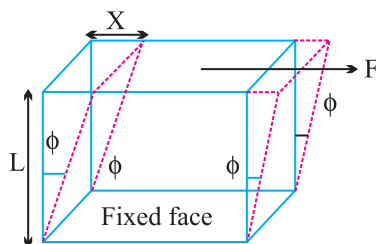

(1) **Linear strain** :
$$\text{Linear strain} = \frac{\text{Change in length}}{\text{Original length}} = \frac{\Delta L}{L}$$

Linear strain in the direction of deforming force is called longitudinal strain and in a direction perpendicular to force is called lateral strain.

(2) **Volumetric strain** :
$$\text{Volumetric strain} = \frac{\text{Change in volume } (\Delta V)}{\text{Original volume } (V)}$$

(3) **Shearing strain** : It is defined as angle in radians through which a plane perpendicular to the fixed surface of the cubical body gets turned under the effect of tangential force.

$$\phi = \frac{X}{L}$$

- When a beam is bent both compression strain as well as an extension strain is produced.

7.7 Stress-strain Curve

- (1) When the strain is small (region OP) stress is proportional to strain. This is the region where the so called Hooke's law is obeyed. The point P is called limit of proportionality and slope of line OP gives the Young's modulus Y of the material of the wire. $Y = \tan \theta$.

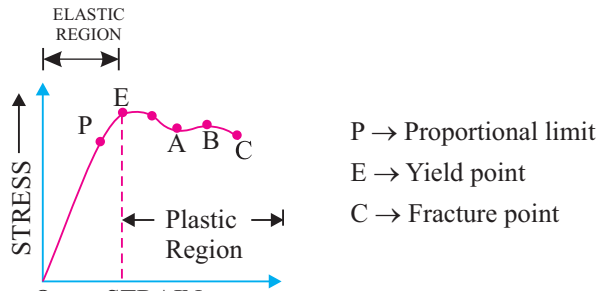

- (2) Point E known as elastic limit or yield-point.
- (3) Between EA, the strain increases much more.
- (4) The region EABC represents the plastic behaviour of the material of wire.
- (5) Stress-strain curve for different materials, are shown in following figure.

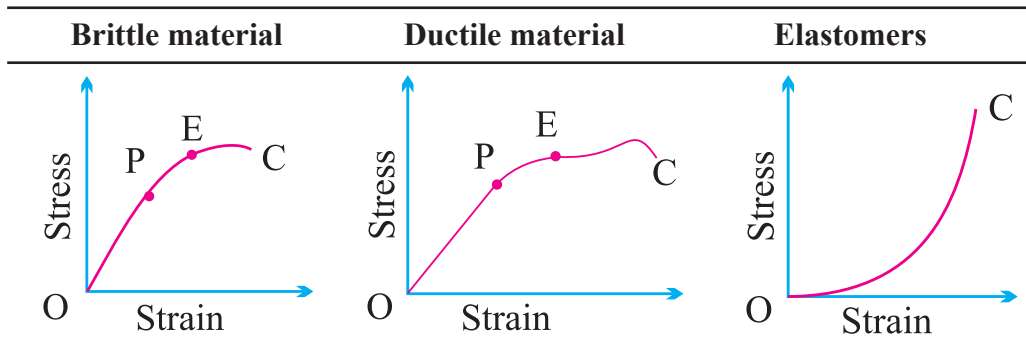

The plastic region between E and C is small for brittle material and it will break soon after the elastic limit is crossed.

AORTA - The large tube (Vessel) carrying blood from heart.

The material on this type have a good plastic range and such materials can be easily changed into different shapes and can be drawn into thin wires.

For elastomers the strain produced is much larger than the stress applied. Such materials have no plastic range and the breaking point lies very close to elastic limit. Example : Elastic tissue of aorta (AORTA)

7.8 Hooke's law and Modulus of Elasticity

According to this law, within the elastic limit, stress is proportional to the strain.

i.e., stress \propto strain

$$\Rightarrow k = \frac{\text{stress}}{\text{strain}} = \text{constant}$$

The constant k is called modulus of elasticity.

- (1) It's value depends upon the nature of material of the body and the manner in which the body is deformed.
- (2) It's value depends upon the temperature of the body.
- (3) It's value is independent of the dimensions of the body.

There are three moduli of elasticity namely Young's modulus (Y), Bulk modulus (K) and modulus of rigidity (η) corresponding to three types of the strain.

7.9 Young's Modulus (Y)

It is defined as the ratio of normal stress to longitudinal strain within limit of proportionality.

$$Y = \frac{\text{Normal stress}}{\text{Longitudinal strain}} = \frac{F/A}{\Delta L/L} = \frac{FL}{A\Delta L}$$

Thermal stress : If a rod is fixed between two rigid supports, due to change in temperature its length will change and so it will exert a normal stress. This stress is called thermal stress. Thermal stress = $Y \propto \Delta\theta$. Force produced in the body = $YA \propto \Delta\theta$. [Here, $\Delta\theta$ = change in temperate.]

7.10 Work Done in Stretching a Wire

In stretching a wire work is done against internal restoring forces. This work is stored in the wire as elastic potential energy or strain energy.

$$\therefore \text{Energy stored in wire } U = \frac{1}{2} \frac{YA l^2}{L} = \frac{1}{2} Fl \quad (l = \text{change in length})$$

Energy stored in per unit volume of wire

$$= \frac{1}{2} \times \text{stress} \times \text{strain} = \frac{1}{2} \times Y \times (\text{strain})^2 = \frac{1}{2Y} (\text{stress})^2$$

7.11 Breaking of Wire

When the wire is loaded beyond the elastic limit, then strain increases much more rapidly. The maximum stress corresponding to B (see stress-strain curve) after which the wire begins to flow and breaks, is called breaking stress or tensile strength and the force by application of which the wire breaks is called the breaking force.

- (i) Breaking force depends upon the area of cross-section of the wire.
- (ii) Breaking stress is a constant for a given material.
- (iii) Breaking force is independent of the length of wire.
- (iv) Breaking force $\propto \pi r^2$.
- (v) Length of wire if it breaks by its own weight

$$L = \frac{P}{dg} \quad [\text{Here, } P \rightarrow \text{Stress or pressure}]$$

[and $d \rightarrow$ Density and $g \rightarrow$ Acceleration due to gravity]

7.12 Bulk Modulus

The ratio of normal stress to the volumetric strain within the elastic limits is called as Bulk modulus.

This is denoted by K .

$$K = \frac{\text{Normal stress}}{\text{Volumetric strain}};$$

$$K = \frac{F/A}{-\Delta V/V} = \frac{-pV}{\Delta V}$$

where p = increase in pressure; V = original volume; ΔV = change in volume

The reciprocal of bulk modulus is called compressibility

$$C = \text{compressibility} = \frac{1}{K} = \frac{\Delta V}{pV}$$

S.I. unit of compressibility is N^{-1}m^2 and C.G.S. unit is $\text{dyne}^{-1} \text{cm}^2$.

Gases have two bulk moduli, namely isothermal elasticity E_θ and adiabatic elasticity E_ϕ .

7.13 Modulus of Rigidity

Within limits of proportionality, the ratio of tangential stress to the shearing strain is called modulus of rigidity of the material of the body and is denoted

by η , *i.e.*,

$$\eta = \frac{\text{Shear Stress}}{\text{Shear strain}} = \frac{F/A}{\phi} = \frac{F}{A\phi}$$

Only solids can exhibit a shearing as these have definite shape.

7.14 Poisson's Ratio

Lateral strain : The ratio of change in radius to the original radius is called lateral strain.

Longitudinal strain : The ratio of change in length to the original length is called longitudinal strain. The ratio of lateral strain to longitudinal strain is called Poisson's ratio (σ).

i.e.,
$$\sigma = \frac{\text{Lateral strain}}{\text{Longitudinal strain}}$$

7.15 Factors Affecting Elasticity

- (1) **Hammering and rolling** : This result is increase in the elasticity of material.
- (2) **Annealing** : Annealing results is decrease in the elasticity of material.
- (3) **Temperature** : Elasticity decreases with rise in temperature but the elasticity of invar steel (alloy) does not change with change of temperature.
- (4) **Impurities** : The type of effect depends upon the nature of impurities present in the material.

7.16 Practical Applications of Elasticity

- (i) The thickness of the metallic rope used in the crane is decided from the knowledge of elasticity.
- (ii) Maximum height of a mountain on earth can be estimated.
- (iii) A hollow shaft is stronger than a solid shaft made of same mass, length and material.

7.17 Intermolecular Force

The force of attraction or repulsion acting between the molecules are known as intermolecular force. The nature of intermolecular force is electromagnetic.

The intermolecular forces of attraction may be classified into two types.

Cohesive force	Adhesive force
The force of attraction between molecules of same substance is called the force of cohesion. This force is lesser in liquids and least in gases.	The force of attraction between the molecules of the different substances is called the force of adhesion.

7.18 Surface Tension

The property of a liquid due to which its free surface tries to have minimum surface area is called surface tension. A small liquid drop has spherical shape due to surface tension. Surface tension of a liquid is measured by the force acting per unit length on either side of an imaginary line drawn on the free surface of liquid, then $T = (F/L)$.

- (1) It depends only on the nature of liquid and is independent of the area of surface or length of line considered.
- (2) It is a scalar as it has a unique direction which is not to be specified.
- (3) Dimension : $[MT^{-2}]$. (Similar to force constant)
- (4) Units : N/m (S.I.) and Dyne/cm [C.G.S.]

7.19 Factors Affecting Surface Tension

- (1) **Temperature** : The surface tension of liquid decreases with rise of temperature

$$T_t = T_0 (1 - \alpha t)$$

where T_t , T_0 are the surface tensions at $t^{\circ}C$ and $0^{\circ}C$ respectively and α is the temperature coefficient of surface tension.

- (2) **Impurities** : A highly soluble substance like sodium chloride when dissolved in water, increases the surface tension of water. But the sparingly soluble substances like phenol when dissolved in water, decreases the surface tension of water.

7.20 Surface Energy

The potential energy of surface molecules per unit area of the surface is called surface energy.

Unit : Joule/m² (S.I.) erg/cm² (C.G.S.)

Dimension : $[MT^{-2}]$

$\therefore W = T \times \Delta A$ [ΔA = Total increase in area of the film from both the sides]

i.e., surface tension may be defined as the amount of work done in increasing the area of the liquid surface by unity against the force of surface tension at constant temperature.

7.21 Splitting of Bigger Drop

When a drop of radius R splits into n smaller drops, (each of radius r) then surface area of liquid increases.

$$R^3 = nr^3$$

$$\begin{aligned} \text{Work done} &= T \times \Delta A = T [\text{Total final surface area of } n \text{ drops} \\ &\quad - \text{surface area of big drop}] = T[4n\pi r^2 - 4\pi R^2]. \end{aligned}$$

7.22 Excess Pressure

Excess pressure in different cases is given in the following table :

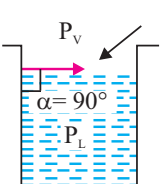
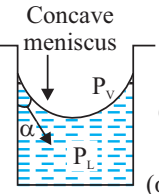
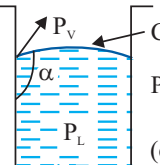
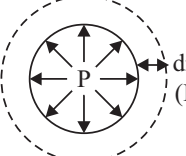
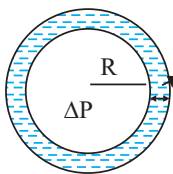
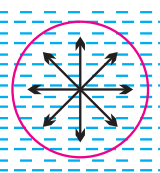
<p style="text-align: center;">Plane surface</p> <p style="text-align: center;">Plane meniscus</p>  <p style="text-align: center;">$\alpha = 90^\circ$ $(\alpha = 90^\circ)$</p> <ul style="list-style-type: none"> <input type="checkbox"/> Adhesive force = cohesive force <input type="checkbox"/> $P_L = P_V$ (i.e., Pressure on both sides of the surface is same) 	<p style="text-align: center;">Concave surface</p> <p style="text-align: center;">Concave meniscus</p>  <p style="text-align: center;">$(P_V > P_L)$ $(\alpha > 90^\circ)$</p> <ul style="list-style-type: none"> <input type="checkbox"/> Adhesive force > Cohesive force <input type="checkbox"/> Liquid wets the solid surface
<p style="text-align: center;">Convex surface</p> <p style="text-align: center;">Convex Meniscus</p>  <p style="text-align: center;">$P_L > P_V$ $(\alpha > 90^\circ)$</p> <ul style="list-style-type: none"> <input type="checkbox"/> Adhesive force < cohesive force <input type="checkbox"/> Liquid does not wet the solid surface 	<p style="text-align: center;">Liquid Drop</p>  <p style="text-align: center;">(Increase in radius)</p> <p style="text-align: center;">Excess pressure inside a liquid drop $(P) = \frac{2T}{R}$</p>
<p style="text-align: center;">Soap Bubble</p>  <p style="text-align: center;">dR (Increase in radius)</p> $\Delta P = \frac{4T}{R}$	<p style="text-align: center;">Air Bubble</p>  <p style="text-align: center;">Excess pressure (ΔP)</p> $\Delta P = \frac{2T}{R}$

7.23 Shape of Liquid Meniscus

The curved surface of the liquid is called meniscus of the liquid.

$$\text{If } F_c = \sqrt{2F_a}$$

$\tan \alpha = \infty \therefore \alpha = 90^\circ$ i.e., the resultant force acts vertically downwards. Hence the liquid meniscus must be horizontal.

$$F_c < \sqrt{2F_a}$$

$\tan \alpha = \text{positive} \therefore \alpha$ is acute angle i.e., the resultant force directed outside the liquid. Hence the liquid meniscus must be concave upward.

$$F_c > \sqrt{2F_a}$$

$\tan \alpha = \text{negative} \therefore \alpha$ is obtuse angle i.e., the resultant force directed inside the liquid. Hence the liquid meniscus must be convex upward.

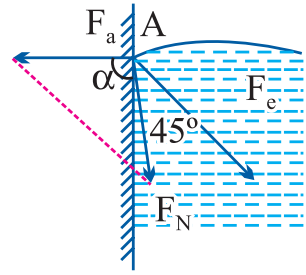
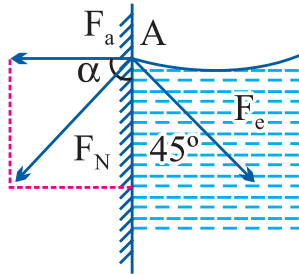
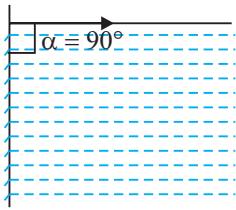

Example : Pure water in silver coated capillary tube.

Example : Water in glass capillary tube.

Example : Mercury in glass capillary tube.

7.24 Angle of Contact

Angle of contact between a liquid and a solid is defined as the angle enclosed between the tangents to the liquid surface and the solid surface inside the liquid, both the tangents being drawn at the point of contact of the liquid with the solid.

$$\theta < 90^\circ$$

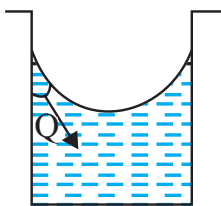

$$Q < 90^\circ$$

concave meniscus.
Liquid wets the solid surface.

$$\theta = 90^\circ$$

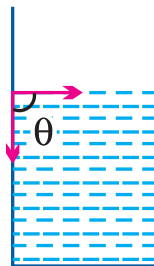

plane meniscus.
Liquid does not wet the solid surface.

$$\theta > 90^\circ$$

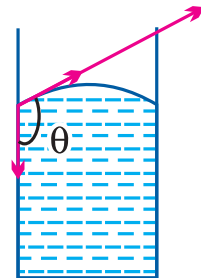

convex meniscus,
does not wet the solid surface.

- (i) Its value lies between 0° and 180° .
 $\theta = 0^\circ$ for pure water and glass, $\theta = 90^\circ$ for water and silver.
- (ii) On increasing the temperature, angle of contact decreases.
- (iii) Soluble impurities increases the angle of contact.
- (iv) Partially soluble impurities decreases the angle of contact.

7.25 Capillarity

If a tube of very narrow bore (called capillary) is dipped in a liquid, it is found that the liquid in the capillary either ascends or descends relative to the surrounding liquid. This phenomenon is called capillarity.

The cause of capillarity is the difference in pressures on two sides curved surface of liquid.

7.26 Ascent Formula

When one end of capillary tube of radius r is immersed into a liquid of density d which wets the sides of the capillary and R = radius of curvature of liquid meniscus.

T = surface tension of liquid

P = atmospheric pressure

$$\therefore h = \frac{2T \cos \theta}{rdg}$$

Important points

- (i) The capillary rise depends on the nature of liquid and solid both *i.e.*, on T , d , θ and R .
- (ii) Capillary action for various liquid-solid pair.

Meniscus	Angle of contact	Level
Concave	$\theta < 90^\circ$	Rises
Plane	$\theta = 90^\circ$	No rise no fall
Convex	$\theta > 90^\circ$	Fall

7.27 Pressure

The normal force exerted by liquid at rest on a given surface in contact with it is called thrust of liquid on that surface.

If F be the normal force acting on a surface of area A in contact with liquid, then

pressure exerted by liquid on this surface is $P = F/A$

(1) **Units** : N/m^2 or Pascal (S.I.) and Dyne/cm^2 (C.G.S.)

(2) **Dimension** : $[P] = \frac{[F]}{[A]} = \frac{[MLT^{-2}]}{[L^2]} = [ML^{-1}T^{-2}]$

(3) Pressure is a tensor quantity.

(4) **Atmospheric pressure** : $\text{atm} = 1.01 \times 10^5 \text{ Pa} = 1.01 \text{ bar} = 1 \text{ torr}$.

(5) If P_0 is the atmospheric pressure then for a point at depth h below the surface of a liquid of density ρ , hydrostatic pressure P is given by $P = P_0 + h\rho g$.

(6) **Gauge pressure** : The pressure difference between hydrostatic pressure P and atmospheric pressure P_0 is called gauge pressure. $P - P_0 + \rho gh$.

7.28 Pascal's Law

The increase in pressure at one point of the enclosed liquid in equilibrium of rest is transmitted equally to all other points of the liquid and also to the walls of the container, provided the effect of gravity is neglected.

Example : Hydraulic lift, hydraulic press and hydraulic brakes.

7.29 Archimedes Principle

When a body is immersed partly or wholly in a fluid, in rest it is buoyed up with a force equal to the weight of the fluid displaced by the body. This principle is called Archimedes principle. Apparent weight of the body of density (ρ) when immersed in a liquid of density (σ).

$$\begin{aligned}\text{Apparent weight} &= \text{Actual weight} - \text{Upthrust} \\ &= W - F_{up} = V\rho g - V\sigma g = V(\rho - \sigma)g \\ &= V\rho g \left(1 - \frac{\sigma}{\rho}\right)\end{aligned}$$

$$\therefore W_{app} = W \left(1 - \frac{\sigma}{\rho}\right)$$

(1) Relative density of a body (R.D.)

$$\begin{aligned}&= \frac{\text{Weight of body in air}}{\text{Weight in air} - \text{weight in water}} \\ &= \frac{W}{W_1 - W_2}\end{aligned}$$

(2) If the loss of weight of a body in water is 'a' while in liquid is 'b'

$$\begin{aligned}\therefore \frac{\sigma_L}{\sigma_w} &= \frac{\text{Upthrust on body in liquid}}{\text{Upthrust on body in water}} \\ &= \frac{\text{Loss of weight in liquid}}{\text{Loss of weight in water}} \\ &= \frac{W_{\text{air}} - W_{\text{liquid}}}{W_{\text{air}} - W_{\text{water}}}\end{aligned}$$

7.30 Streamline, Laminar and Turbulent Flow

(1) **Stream line flow** : Stream line flow of a liquid is that flow in which each element of the liquid passing through a point travels along the same path and with the same velocity as the preceding element passes through that point.

The two streamlines cannot cross each other and the greater is the crowding of streamlines at a place, the greater is the velocity of liquid particles at that place.

(2) **Laminar flow** : If a liquid is flowing a horizontal surface with a steady flow and moves in the form of layers of different velocities which do not mix with each other, then the flow of liquid is called laminar flow.

In this flow the velocity of liquid flow is always less than the critical velocity of the liquid.

(3) **Turbulent flow** : When a liquid moves with a velocity greater than its critical velocity, the motion of the particles of liquid becomes disordered or irregular. Such a flow is called a turbulent flow.

7.31 Critical Velocity

The critical velocity is that velocity of liquid flow upto which its flow is streamlined and above which its flow becomes turbulent.

7.32 Equation of Continuity

The equation of continuity is derived from the principle of conservation of mass.

For an incompressible, streamlined and non-viscous liquid product of area of cross section of tube and velocity of liquid remains constant.

i.e.,
$$a_1 v_1 = a_2 v_2$$

or

$$av = \text{constant}; \text{ or } a \propto \frac{1}{v}$$

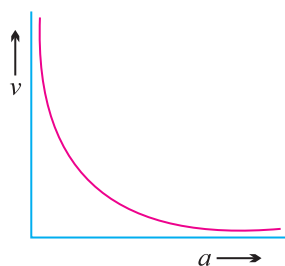

When water falls from a tap, the velocity of falling water under the action of gravity will increase with distance from the tap (*i.e.*, $v_2 > v_1$). So in accordance with continuity equation the cross section of the water stream will decrease (*i.e.*, $A_2 < A_1$), *i.e.*, the falling stream of water becomes narrower.

7.33 Energy of a Flowing Fluid

Pressure Energy	Potential energy	Kinetic energy
It is the energy possessed by a liquid by virtue of its pressure. It is the measure of work done in pushing the liquid against pressure without imparting any velocity to it.	It is the energy possessed by liquid by virtue of its height or position above the surface of earth or any reference level taken as zero level.	It is the energy possessed by a liquid by virtue of its motion or velocity.
Pressure energy of the liquid PV Pressure energy per unit mass of the liquid $\frac{P}{\rho}$ Pressure energy per unit volume of the liquid P	Potential energy of the liquid mgh Potential energy per unit mass of the liquid gh Potential energy per unit volume of the liquid ρgh	Kinetic energy of the liquid $\frac{1}{2}mv^2$ Kinetic energy per unit mass of the liquid $\frac{1}{2}v^2$ Kinetic energy per unit volume of the liquid $\frac{1}{2}\rho v^2$

7.34 Bernoulli's Theorem

According to this theorem the total energy (pressure energy, potential energy and kinetic energy) per unit volume or mass of an incompressible and non-viscous fluid in steady flow through a pipe remains constant throughout the flow.

$$P + \rho gh + \frac{1}{2}\rho v^2 = \text{constant}$$

(i) Bernoulli's theorem for unit mass of :

$$\frac{P}{\rho} + gh + \frac{1}{2}v^2 = \text{constant}$$

(ii) Dividing above equation by g , we get

$$\frac{P}{\rho g} + h + \frac{v^2}{2g} = \text{constant}$$

Here $\frac{P}{\rho g}$ is called pressure head, h is called gravitational head and $\frac{v^2}{2g}$ is called velocity head.

7.35 Applications of Bernoulli's Theorem

(i) Attraction between two closely parallel moving boats.

(ii) **Working of an aeroplane** : 'dynamic lift'
(= pressure difference \times area of wing)

(iii) **Action of atomiser** :

(iv) **Blowing off roofs by wind storms**

(v) **Magnus effect** : When a spinning ball is thrown, it deviates from its usual path in flight. This effect is called Magnus effect.

(vi) **Venturimeter** : It is a device used for measuring the rate of flow of liquid through pipes.

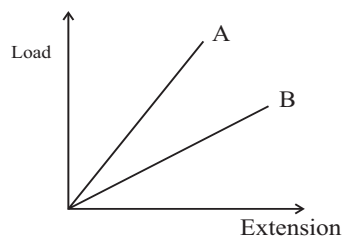

$$\text{Rate of flow of liquid } V = a_1 a_2 \sqrt{\frac{2hg}{a_1^2 - a_2^2}}$$

7.36 Velocity of Efflux

Velocity of efflux from a hole made at a depth h below the free surface of the liquid (of depth H) is given by $v = \sqrt{2gh}$.

Which is same as the final speed of a free falling object from rest through a height h . This result is known as Torricelli's theorem.

7.37 Viscosity and Newton's law of Viscous Force

The property of a fluid due to which it opposes the relative motion between its different layers is called viscosity (or fluid friction or internal friction) and the force between the layers opposing the relative motion is called viscous force.

Viscous force F is proportional to the area of the plane A and the velocity gradient $\frac{dv}{dx}$ in a direction normal to the layer,

i.e.,
$$F = -\eta A \frac{dv}{dx}$$

Where η is a constant called the coefficient of viscosity. Negative sign is employed because viscous force acts in a direction opposite to the flow of liquid.

- (1) Units : dyne-s-cm⁻² or Poise (C.G.S. system);
Newton-s-m⁻² or Poiseuille or decapoise (S.I. system)
1 Poiseuille = 1 decapoise = 10 Poise
- (2) Dimension : [ML⁻¹T⁻¹]
- (3) With increase in pressure, the viscosity of liquids (except water) increases while that of gases is independent of pressure. The viscosity of water decreases with increase in pressure.
- (4) Solid friction is independent of the area of surfaces in contact and the relative velocity between them.
- (5) Viscosity represents transport of momentum, while diffusion and conduction represents transport of mass and energy respectively.
- (6) The viscosity of gases increases with increase of temperature.
- (7) The viscosity of liquid decreases with increase of temperature.

7.38 Stoke's Law and Terminal Velocity

Stokes established that if a sphere of radius r moves with velocity v through a fluid of viscosity η , the viscous force opposing the motion of the sphere is $F = 6\pi\eta rv$ (stokes law)

If a spherical body of radius r is dropped in a viscous fluid, it is first accelerated and then its acceleration becomes zero and it attains a constant velocity called terminal velocity.

$$\text{Terminal velocity } v = \frac{2}{9} \frac{r^2(\rho - \sigma)g}{\eta}$$

- (i) If $\rho > \sigma$ then body will attain constant velocity in downward direction.
- (ii) If $\rho < \sigma$ then body will attain constant velocity in upward direction.

Example : Air bubble in a liquid and clouds in sky.

(iii) Terminal velocity graph :

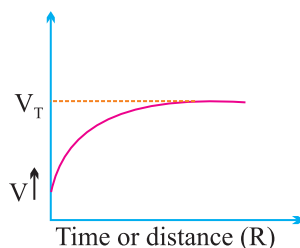

7.39 Poiseuille's Formula

Poiseuille studied the stream-line flow of liquid in capillary tubes. He found that if a pressure difference (P) is maintained across the two ends of a capillary tube of length ' l ' and radius r , then the volume of liquid coming out of the tube per second is

$$V = \frac{\pi P r^4}{8 \eta l} \quad (\text{Poiseuille's equation})$$

This equation also can be written as, $V = \frac{P}{R}$ where $R = \frac{8 \eta l}{\pi r^4}$

R is called as liquid resistance.

3.40 Stefan's Law

According to it the radiant energy emitted by a perfectly black body per unit area per sec (*i.e.*, emissive power of black body) is directly proportional to the fourth power of its absolute temperature.

$$\text{i.e.,} \quad E \propto T^4 \text{ or } E = \sigma T^4$$

where σ = Stefan's constant having dimension $[MT^{-3}\theta^{-4}]$ and value $5.67 \times 10^{-8} \text{ W/m}^2\text{K}^4$.

(i) If e is the emissivity of the body then $E = e \sigma T^4$

(ii) If Q is the total energy radiated by the body then $Q = A t e \sigma T^4$

(iii) If a body at temperature T is surrounded by a body at temperature T_0 , then $E = e \sigma (T^4 - T_0^4)$.

Nature of thermal Radiation

- Radiation emitted by a black body is a mixture of waves of different wavelengths and only a small range of wavelength has significant contribution in the total radiation.

- A body is heated at different temperature and Energy of radiation is plotted against wavelength is plotted for different temperature we get following curves.

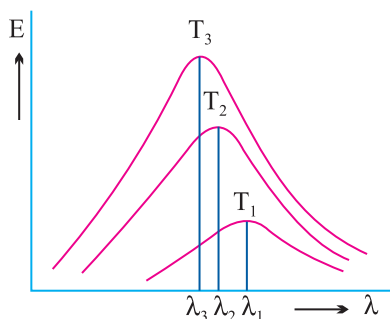

- These curves show
 - (i) Energy is not uniformly distributed in the radiation spectrum of black body.
 - (ii) At a given temperature the intensity of radiations increases with increase in wavelength, becomes maximum at particular wavelength and further increase in wavelength leads to decrease in intensity of heat radiation.
 - (iii) Increase in temperature causes increase in energy emission for all wavelengths.
 - (iv) Increase in temperature causes decrease in λ_m , where λ_m is wavelength corresponding to highest intensity. This wavelength λ_m is inversely pre-operational to the absolute temperature of the emitter. $\lambda_m T = b$

where b is a constant and this equation is known as Wein's displacement law. $b = 0.2896 \times 10^{-2} \text{ mk}$ for black body and is known as Wien's constant.

Very Short Answer Questions (1 Mark)

1. Why do spring balances show wrong readings after they have been used for a long time ?
2. Why do we prefer steel to copper in the manufacture of spring ?
3. Draw stress-strain curve for elastomers (elastic tissue of Aorta)
4. How are we able to break a wire by repeated bending ?
5. What is the value of bulk modulus for an incompressible liquid ?

6. Define Poisson's ratio ? Does it have any unit ?
7. What is elastic fatigue ?
8. Why is it easier to swim in sea water than in the river water ?
9. Railway tracks are laid on large sized wooden sleepers. Why ?
10. The dams of water reservoir are made thick near the bottom. Why ?
11. Why is it difficult to stop bleeding from a cut in human body at high altitude ?
12. The blood pressure in human is greater at the feet than at the brain. Why ?
13. Define coefficient of viscosity and write its SI unit.
14. Why machine parts get jammed in winter ?
15. Why do the clouds float in the sky ?
16. Antiseptics have low surface tension. Why ?
17. What will be the effect of increasing temperature on (i) angle of contact (ii) surface tension ?
18. For solids with elastic modulus of rigidity, the shearing force is proportional to shear strain. On what factor does it depend in case of fluids ?
19. How does rise in temperature effect (i) viscosity of gases (ii) viscosity of liquids ?
20. Explain why detergents should have small angle of contact ?
21. Write the dimensions of coefficient of viscosity and surface tension.
22. Obtain a relation between SI unit and cgs unit of coefficient of viscosity.
23. Explain, how the use of parachute helps a person jumping from an aeroplane.
24. Why two ships moving in parallel directions close to each other get attracted ?
25. Why the molecules of a liquid lying near the free surface possess extra energy ?
26. Why is it easier to wash clothes in hot water soap solution ?

27. Why does mercury not wet glass ?
28. Why ends of a glass tube become rounded on heating ?
29. What makes rain coats water proof ?
30. What happens when a capillary tube of insufficient length is dipped in a liquid ?
31. Does it matter if one uses gauge pressure instead of absolute pressure in applying Bernoulli's equation ?
32. State Wein's displacement law for black body radiation.
33. State Stefan Boltzmann law.
34. Name two physical changes that occur on heating a body.
35. Distinguish between heat and temperature.
36. Which thermometer is more sensitive a mercury or gas thermometer ?
37. Metal disc has a hole in it. What happens to the size of the hole when disc is heated ?
38. Name a substance that contracts on heating.
39. A gas is free to expand what will be its specific heat ?
40. Is the bulb of a thermometer made of diathermic or adiabatic wall ?
41. What is the absorptive power of a perfectly black body ?
42. At what temperature does a body stop radiating ?
43. If Kelvin temperature of an ideal black body is doubled, what will be the effect on energy radiated by it ?
44. In which method of heat transfer does gravity not play any part ?
45. Give a plot of Fahrenheit temperature versus Celsius temperature.
46. Why birds are often seen to swell their feather in winter ?
47. A brass disc fits snugly in a hole in a steel plate. Should we heat or cool the system to loosen the disc from the hole.

Short Answer Type Questions (2 Marks)

48. State Hooke's law. Deduce expression for Young's modulus of material of a wire of length ' l ', radius of cross-section ' r ' loaded with a body of mass M producing an extension Δl in it.
49. A wire of length l area of cross-section A and Young's modulus Y is stretched by an amount x . What is the work done ?
50. Prove that the elastic potential energy per unit volume is equal to $\frac{1}{2} \times$ stress \times strain.
51. Define the term bulk modulus. Give its SI unit. Give the relation between bulk modulus and compressibility.
52. Define shear modulus. With the help of a diagram explain how shear modulus can be calculated.
53. Which is more elastic steel or rubber. Explain.
54. Two wires P and Q of same diameter are loaded as shown in the figure. The length of wire P is L m and its Young's modulus is Y N/m² while length of wire Q is twice that of P and its material has Young's modulus half that of P. Compute the ratio of their elongation.

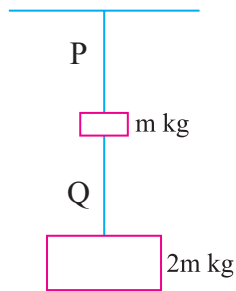

55. In case of emergency, a vacuum brake is used to stop the train. How does this brake works ?
56. Define surface tension and surface energy. Obtain a relation between them.
57. State and prove Torricelli's theorem for velocity of efflux.
58. Using dimensional method obtain, Stoke's law expression for viscous force $F = 6\pi \eta a v$.
59. The fig (a) & (b) refer to the steady flow of a non-viscous liquid which of

the two figures is incorrect ? Why ?

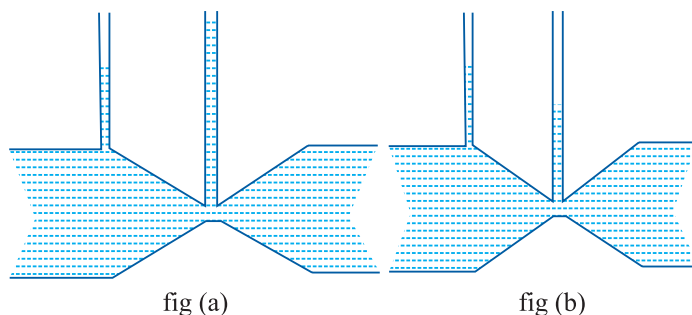

60. The fig. below shows a thin liquid supporting a small weight 4.5×10^{-2} N. What is the weight supported by a film of same liquid at the same temperature in fig. (b) & (c). Explain your answer.

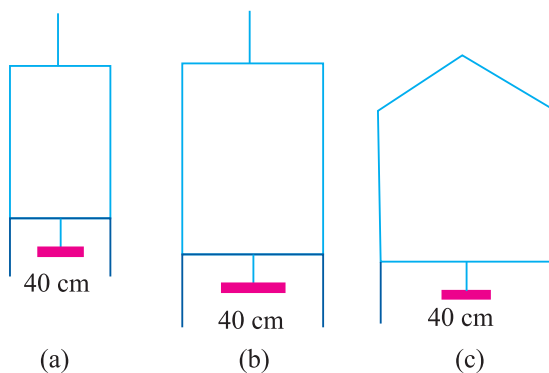

61. Two soap bubbles of different diameter are in contact with a certain portion common to both the bubbles. What will be the shape of the common boundary as seen from inside the smaller bubble ? Support your answer with a neat diagram and justify your answer.
62. During blood transfusion the needle is inserted in a vein where gauge pressure is p_g and atmospheric pressure is p . At what height must the blood container be placed so that blood may just enter the vein. Given density of blood is ρ .
63. Why we cannot remove a filter paper from a funnel by blowing air into narrow end.
64. On a hot day, a car is left in sunlight with all windows closed. Explain why it is considerably warmer than outside, after some time ?
65. A capillary tube is dipped first in cold water and then in hot water. Comment on the capillary rise in the second case.

66. If a drop of water falls on a very hot iron, it does not evaporate for a long time. Why ?
67. The earth without its atmosphere would be inhospitably cold. Why ?
68. The coolant used in chemical or in a nuclear plant should have high specific heat. Why ?
69. A sphere, a cube and a disc made of same material and of equal masses heated to same temperature of 200°C . These bodies are then kept at same lower temperature in the surrounding, which of these will cool (i) fastest, (ii) slowest, explain.
70. (a) Why pendulum clocks generally go faster in winter and slow in summer.
(b) Why the brake drums of a car are heated when it moves down a hill at constant speed.
71. The plots of intensity versus wavelength for three black bodies at temperature T_1 , T_2 and T_3 respectively are shown.

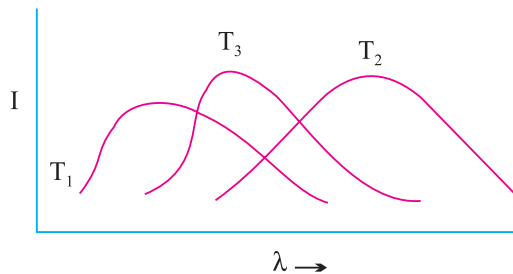

Arrange the temperature in decreasing order. Justify your answer.

72. The triple point of water is a standard fixed point in modern thermometry. Why ? Why melting point of ice or boiling point of water not used as standard fixed points.

Short Answer Type Questions (3 Marks)

73. The knowledge of elasticity useful in selecting metal ropes show its use, in cranes for lifting heavy loads, when rope of steel is used (Elastic limit $30 \times 10^7 \text{ Nm}^{-2}$) if load of 10^5 kg is to be lifted.

What should be the radius of steel rope ? What should we do to increase flexibility of such wire ?

74. Stress-strain curve for two wires of material A and B are as shown in Fig.

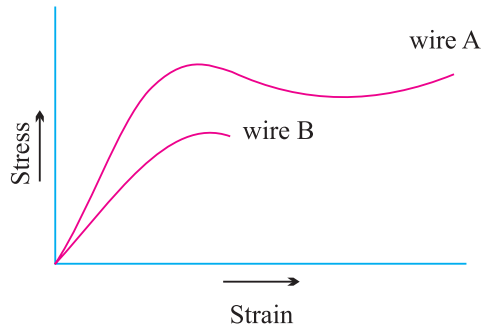

- which material is more ductile ?
 - which material has greater value of young modulus ?
 - which of the two is stronger material ?
 - which material is more brittle ?
75. State Pascal's law for fluids with the help of a neat labelled diagram explain the principle and working of hydraulic brakes.
76. A manometer reads the pressure of a gas in an enclosure as shown in the fig. (a) when some of the gas is removed by a pump, the manometer reads as in fig (b). The liquid used in manometer is mercury and the atmospheric pressure is 76 cm of mercury, (i) Give absolute and gauge pressure of the gas in the enclosure for cases (a) and (b).

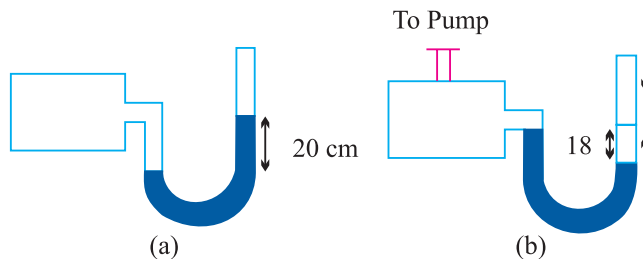

77. How would the levels change in (b) if 13.6 cm of H_2O (immiscible with mercury) are poured into the right limb of the manometer in the above numerical.
78. Define Capillarity and angle of contact. Derive an expression for the ascent of a liquid in a capillary tube.
79. The terminal velocity of a tiny droplet is v . N number of such identical

droplets combine together forming a bigger drop. Find the terminal velocity of the bigger drop.

80. Two spherical soap bubble coalesce. If v be the change in volume of the contained air, A is the change in total surface area then show that $3PV + 4AT = 0$ where T is the surface tension and P is atmospheric pressure.
81. Give the principle of working of venturi-meter. Obtain an expression for volume of liquid flowing through the tube per second.
82. A big size balloon of mass M is held stationary in air with the help of a small block of mass $M/2$ tied to it by light string such that both float in mid air. Describe the motion of the balloon and the block when the string is cut. Support your answer with calculations.
83. Two vessels have the same base area but different shapes. The first vessels takes twice the volume of water that the second vessel requires to fill upto a particular common height. Is the force exerted by the water on the base of the vessel the same ? Why do the vessels filled to same height give different reading on weighing scale.
84. A liquid drop of diameter D breaks up into 27 tiny drops. Find the resulting change in energy. Take surface tension of liquid as σ .
85. Define the coefficients of linear expansion. Deduce relation between it and coefficient of superficial expansion and volume expansion.
86. Describe the different types of thermometers commonly used. Used the relation between temperature on different scales. Give four reasons for using mercury in a thermometer.
87. Two rods of different metals of coefficient of linear expansion α_1 and α_2 and initial length l_1 and l_2 respectively are heated to the same temperature. Find relation in α_1, α_2, l_1 and l_2 such that difference between their lengths remain constant.
88. Explain why :
- (a) a body with large reflectivity is a poor emitter.
 - (b) a brass tumbler feels much colder than a wooden tray on a chilly day.
89. Draw a graph to show the anomalous behaviour of water. Explain its importance for sustaining life under water.

90. A brass wire 1.8 m long at 27°C is held taut with little tension between two rigid supports. If the wire is cooled to a temperature of – 39°C, what is the tension developed in the wire, if its diameter is 2.0 mm ? Coefficient of linear expansion of brass = $2.0 \times 10^{-5} \text{C}^{-1}$, Young's modulus of brass = $0.91 \times 10^{11} \text{ Pa}$.
91. Define (i) Specific heat capacity (ii) Heat capacity (iii) Molar specific heat capacity at constant pressure and at constant volume and write their units.
92. What is latent heat ? Give its units. With the help of a suitable graph, explain the terms latent heat of fusion and latent heat of vaporisation.
93. What is the effect of pressure on melting point of a substance ? What is regelation. Give a practical application of it.
94. What is the effect of pressure on the boiling point of a liquid. Describe a simple experiment to demonstrate the boiling of H_2O at a temperature much lower than 100°C. Give a practical application of this phenomenon.
95. State and explains the three modes of transfer of heat. Explains how the loss of heat due to these three modes is minimised in a thermos flask.
96. Define coefficient of thermal conductivity. Two metal slabs of same area of cross-section, thickness d_1 and d_2 having thermal conductivities K_1 and K_2 respectively are kept in contact. Deduce expression for equivalent thermal conductivity.

Long Answer Type Questions (5 Marks)

97. Draw and discuss stress versus strain graph, explaining clearly the terms elastic limit, permanent set, proportionality limit, elastic hysteresis, tensile strength.
98. Show that there is always an excess pressure on the concave side of the meniscus of a liquid. Obtain an expression for the excess pressure inside (i) a liquid drop (ii) soap bubble (iii) air bubble inside a liquid.
99. State and prove Bernoulli's theorem. Give its limitation. Name any two application of the principle.
100. Define terminal velocity. Obtain an expression for terminal velocity of a sphere falling through a viscous liquid. Use the formula to explain the observed rise of air bubbles in a liquid.
101. On what factors does the rate of heat conduction in a metallic rod in the steady state depend. Write the necessary expression and hence define the coefficient of thermal conductivity. Write its unit and dimensions.

- 102.** Show graphically how the energy emitted from a hot body varies with the wavelength of radiation. Give some of salient points of the graph.
- 103.** What is meant by a black body. Explain how a black body may be achieved in practice. State and explain Stefan's law ?
- 104.** State and prove Pascal's law of transmission of fluid pressure. Explain how is Pascal's law applied in a hydraulic lift.
- 105.** Discuss energy distribution of black body radiation spectrum and explain Wein's displacement law of radiation and Stefan's law of heat radiation.

NUMERICALS

- 106.** An aluminium wire 1 m in length and radius 1 mm is loaded with a mass of 40 kg hanging vertically. Young's modulus of Al is 7.0×10^{10} N/m². Calculate (a) tensile stress (b) change in length (c) tensile strain and (d) the force constant of such a wire.
- 107.** The average depth of ocean is 2500 m. Calculate the fractional compression $\left(\frac{\Delta V}{V}\right)$ of water at the bottom of ocean, given that the bulk modulus of water is 2.3×10^9 N/m².
- 108.** A force of 5×10^3 N is applied tangentially to the upper face of a cubical block of steel of side 30 cm. Find the displacement of the upper face relative to the lower one, and the angle of shear. The shear modulus of steel is 8.3×10^{10} pa.
- 109.** How much should the pressure on one litre of water be changed to compress it by 0.10%.
- 110.** Calculate the pressure at a depth of 10 m in an Ocean. The density of sea water is 1030 kg/m³. The atmospheric pressure is 1.01×10^5 pa.
- 111.** In a hydraulic lift air exerts a force F on a small piston of radius 5 cm. The pressure is transmitted to the second piston of radius 15 cm. If a car of mass 1350 kg is to be lifted, calculate force F that is to be applied.
- 112.** How much pressure will a man of weight 80 kg f exert on the ground when (i) he is lying and (2) he is standing on his feet. Given area of the body of the man is 0.6 m² and that of his feet is 80 cm².
- 113.** The manual of a car instructs the owner to inflate the tyres to a pressure of 200 k pa. (a) What is the recommended gauge pressure ? (b) What is the recommended absolute pressure (c) if, after the required inflation of the tyres,

the car is driven to a mountain peak where the atmospheric pressure is 10% below that at sea level, what will the tyre gauge read ?

- 114.** Calculate excess pressure in an air bubble of radius 6 mm. Surface tension of liquid is 0.58 N/m.
- 115.** Terminal velocity of a copper ball of radius 2 mm through a tank of oil at 20°C is 6.0 cm/s. Compare coefficient of viscosity of oil. Given $p_{\text{cu}} = 8.9 \times 10^3 \text{ kg/m}^3$, $\rho_{\text{oil}} = 1.5 \times 10^3 \text{ kg/m}^3$.
- 116.** Calculate the velocity with which a liquid emerges from a small hole in the side of a tank of large cross-sectional area if the hole is 0.2 m below the surface liquid ($g = 10 \text{ ms}^{-2}$).
- 117.** A soap bubble of radius 1 cm expands into a bubble of radius 2 cm. Calculate the increase in surface energy if the surface tension for soap is 25 dyne/cm.
- 118.** A glass plate of 0.2 m^2 in area is pulled with a velocity of 0.1 m/s over a larger glass plate that is at rest. What force is necessary to pull the upper plate if the space between them is 0.003 m and is filled with oil of η 0.01 Ns/m².
- 119.** The area of cross-section of a water pipe entering the basement of a house is $4 \times 10^{-4} \text{ m}^2$. The pressure of water at this point is $3 \times 10^5 \text{ N/m}^2$, and speed of water is 2 m/s. The pipe tapers to an area of cross section of $2 \times 10^{-4} \text{ m}^2$, when it reaches the second floor 8 m above the basement. Calculate the speed and pressure of water flow at the second floor.
- 120.** A large bottle is fitted with a siphon made of capillary glass tubing. Compare the times taken to empty the bottle when it is filled (i) with water (ii) with petrol of density 0.8 cgs units. The viscosity of water and petrol are 0.01 and 0.02 cgs units respectively.
- 121.** The breaking stress for a metal is $7.8 \times 10^9 \text{ Nm}^{-2}$. Calculate the maximum length of the wire made of this metal which may be suspended without breaking. The density of the metal = $7.8 \times 10^{-3} \text{ kg m}^{-3}$. Take $g = 10 \text{ N kg}^{-1}$.
- 122.** Two stars radiate maximum energy at wavelength, $3.6 \times 10^{-7} \text{ m}$ and $4.8 \times 10^{-7} \text{ m}$ respectively. What is the ratio of their temperatures ?
- 123.** Find the temperature of 149°F on kelvin scale.
- 124.** A metal piece of 50 g specific heat 0.6 cal/g°C initially at 120°C is dropped in 1.6 kg of water at 25°C. Find the final temperature or mixture.

133. A rigid bar of Mass M is supported symmetrically by three wires each of length L . Those at each end one of Copper and the middle one is of iron. The ratio of their diameters, if each is to have the same tension, is equal to

- (a) $\frac{Y_{\text{copper}}}{Y_{\text{iron}}}$ (b) $\sqrt{\frac{Y_{\text{iron}}}{Y_{\text{copper}}}}$
 (c) $\frac{Y^2_{\text{iron}}}{Y^2_{\text{copper}}}$ (d) $\frac{Y_{\text{iron}}}{Y_{\text{copper}}}$

134. A mild steel wire of Length $2L$ and cross sectional Area A is stretched well within elastic limit, horizontally between two pillars. A man m is suspended from the mid point of the wire strain in the wire is

- (a) $\frac{x^2}{2L^2}$ (b) $\frac{x}{L}$
 (c) $\frac{x^2}{L}$ (d) $\frac{x^2}{2L}$

135. For an ideal liquid : (More than one option may be correct)

- (a) the bulk modulus is infinite (b) the bulk modulus is zero
 (c) the shear modulus is infinite (d) the shear modulus is zero

136. The stress strain graph for this materials are shown figure. (Assume scale is same for both graph)

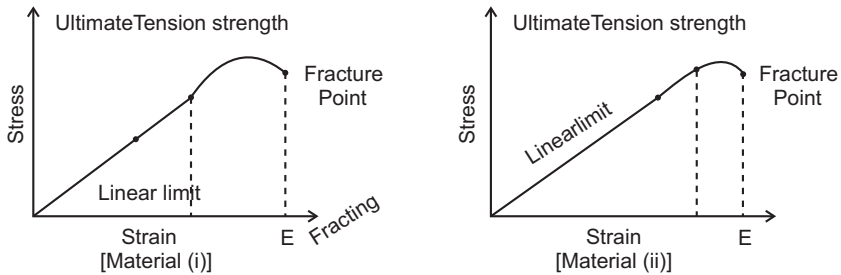

- (a) Material (ii) is more elastic than material (i) and hence material (ii) is more brittle.
 (b) Material (i) & (ii) have the same elasticity and the same brittleness.
 (c) Material (ii) is elastic over the larger region of strain as compared to (i)
 (d) Material (ii) is more brittle than material (i)

142. As the temperature is increased, the time period of pendulum
- increases as its effective length increases even though its centre of mass (CM) still remains at the centre of the bob
 - decreases as its effective length increases even though its CM still remains at the centre of the bob
 - increases as its effective length increases due to shifting of CM below the centre of the bob
 - decreases as its effective length remains same but the CM shifts above the centre of the bob.
143. Refer to the plot of temperature versus time showing the changes in the state of ice on heating (not of scale)

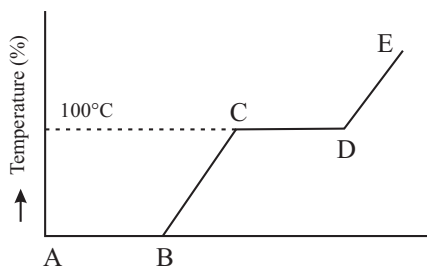

Which of the following is correct :

- The region AB represents ice & water in thermal equilibrium
 - At B water starts boiling
 - At C all the water gets converted into steam
 - C-D represents water & steam in equilibrium at boiling point.
144. A student records the initial length l , change in temperature ΔT and change in length Δl of a rod as follows :

S.No.	l (m)	ΔT ($^{\circ}\text{C}$)	Δl (m)
1	2	10	4×10^{-4}
2	1	10	4×10^{-4}
3	2	20	2×10^{-4}
4	3	10	6×10^{-4}

If the first observation is correct. Choose the correct answer about 2nd, 3rd & 4th observations

- 2nd observation correct
- 3rd observation correct
- 4th observation correct
- 4th observation incorrect

145. The approximate depth of an ocean is 2700 m. The compressibility of water is $45.4 \times 10^{-11} \text{ Pa}^{-1}$ and density of water is 10^3 kg/m^3 . What fractional compression of water will be obtained at the bottom of the ocean?
- (a) 1.0×10^{-2} (b) 1.2×10^{-2}
 (c) 1.4×10^{-2} (d) 0.8×10^{-2}
146. The Young's Modulus of steel is twice that of brass. Two wires of same length and of same area of cross-section; one of steel and another of brass are suspended from the same roof. If then the weights added to the steel and brass wires must be in the ratio of
- (a) 1 : 1 (b) 1 : 2
 (c) 2 : 1 (d) 4 : 2
147. Two rods of different materials having coefficients of thermal expansion α_1, α_2 and Young's Moduli Y_1, Y_2 respectively are fixed between two rigid massive walls. The rods are heated such that they undergo the same increase in temperature. There is no bending of the rods. If $\alpha_1 : \alpha_2 = 2 : 3$, the thermal stresses developed in the two rods are equal provided $Y_1 : Y_2$ is equal to
- (a) 2 : 3 (b) 1 : 1
 (c) 3 : 2 (d) 4 : 9
148. In the given figure; if the dimension of the two wires are the same and materials are different. Young's modulus is

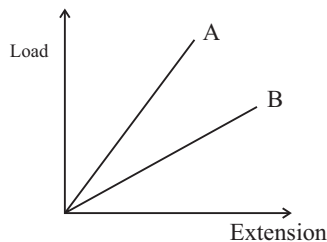

- (a) More for A than B (b) More for B than A
 (c) Equal for A & B (d) None of these
149. The two ends of a metal rod are maintained at temperatures 100°C and 110°C . The rate of heat flow in the rod is found to be 4.0 J/s . If the ends are now maintained at temperatures 200°C and 210°C , the rate of flow of heat will be
- (a) 16.8 J/s (b) 8.0 J/s
 (c) 4.0 J/s (d) 44.8 J/s

150. Steam at 100°C is passed into 20 g of water at 10°C , then water acquires a tempering of 80°C , the mass of water present will be [Take specific heat of water = $1 \text{ cal g}^{-1} \text{ }^{\circ}\text{C}^{-1}$ and Latent heat of steam = 540 cal g^{-1}]
- (a) 24 g (b) 31.5 g
(c) 42.5 g (d) 22.5 g

ASSERTION - REASON BASED QUESTIONS

Direction:- In the following questions, a statement of assertion is followed by a statement of reason. Mark the correct choice as :

- (a) If both assertion and reason are true and reason is the correct explanation of assertion.
(b) If both assertion and reason are true but reason is not correct explanation of assertion..
(c) If assertion is true, but reason is false.
(d) If both assertion and reason are false.

1. Assertion : The size of hydrogen balloon increases as it rises in the air.

Reason : The material of balloon can be easily stretched.

2. Assertion : Stress is the internal force per unit area of a body.

Reason : Rubber is more elastic than steel.

3. Assertion : A rigid body can be elastic.

Reason : If force is applied on rigid body, its dimension may change.

4. Assertion : Transverse sound waves do not occur in gases.

Reason : Gases can not sustain shearing strain.

5. Assertion : The shape and size of rigid body remain unaffected under the effect of external forces.

Reason : The distance between two particles remains constant in rigid body.

6. Assertion : A lead is more elastic than rubber.

Reason : If same load is applied on the lead and rubber wire of same cross-sectional area, the strain of lead is very much less than that of rubber.

7. Assertion : Bulk modulus of elasticity B represents incompressibility of the material.

Reason : $B = \frac{-\Delta PV}{\Delta V}$ where symbols have their usual meaning.

8. Assertion : The bridges declared unsafe after long use.
Reason : Elastic strength of bridges losses with time.
9. Assertion : Young's modulus for a perfectly plastic body is zero.
Reason : For perfectly plastic body restoring force is zero.
10. Assertion : Strain is a unit less quantity.
Reason : Strain is equivalent to force.
11. Assertion : The blood pressure in human is greater at the feet than at brain.
Reason : Pressure of liquid at any point is proportional to height, density of liquid and acceleration due to gravity.
12. Assertion : The velocity increases, when water flowing in a broader pipe enter a narrow pipe.
Reason : According to equation of continuity, product of area of cross-section and velocity is constant.
13. Assertion : The velocity of fall of a man jumping with a parachute first increases and then becomes constant.
Reason : The constant velocity of fall of man is called terminal velocity.
14. Assertion : The velocity of flow of a liquid is smaller when pressure is larger and vice versa.
Reason : According to Bernoulli's theorem for the stream line flow of an ideal fluid, the total energy per unit mass remains constant.
15. Assertion : Sudden fall of pressure at a place indicate storm.
Reason : Air flows from higher pressure to lower pressure.
16. Assertion : To empty an oil tank, two holes are made.
Reason : Oil will come out of two holes, so it will be emptied faster.
17. Assertion : A rain drop after falling through some height attains a constant velocity.
Reason : At constant velocity, the viscous drag is just equal to it's weight.
18. Assertion : The water rises higher in a capillary table of small diameter than in the capillary tube of large diameter.
Reason : Height through which liquid rises in a capillary tube is inversely proportional to the diameter of the capillary tube.

CASE STUDY BASED QUESTIONS

Q1. Bernoulli's theorem, in fluid dynamics, relation among the pressure, velocity and elevation in a moving fluid (liquid or gas), the compressibility and viscosity of which are negligible and the flow of which is steady, or laminar. Bernoulli's principle is applicable on those non-viscous liquids which have laminar or stream lined flow. It means that a liquid in which its particles exert no force on each other i.e. the speed of all particles of the liquid is same.

Answer the following questions (any four)

- (i) Bernoulli's principle is based on the conservation of
- (a) momentum
 - (b) energy and momentum both
 - (c) mass
 - (d) energy
- (ii) Water is following through a horizontal pipe in a streamline flow, at the narrowest part of the pipe
- (a) both pressure and velocity remains constant.
 - (b) velocity is maximum and pressure is minimum.
 - (c) both the pressure and velocity are maximum.
 - (d) both the pressure and velocity are minimum.
- (iii) In houses far away from municipal water tanks often find it difficult to get water on the top floor. This happens because
- (a) water wets the pipe.
 - (b) the pipes are not of uniform diameter.
 - (c) the viscosity of water is high.
 - (d) of loss of pressure during the flow of water.
- (iv) In which of the following types of flows is the Bernoulli's theorem strictly applicable
- (a) streamline and rotational
 - (b) turbulent and rotational
 - (c) turbulent and irrotational
 - (d) streamline and irrotational
- (v) Viscosity of gases
- (a) decreases with increases in temperature
 - (b) independent of temperature
 - (c) increases with increase in temperature
 - (d) may increase or decrease depend on nature of gas

Q2. Ram was doing an experiment in physics lab to find co-efficient of viscosity of glycerine. In this experiment the drop lead shots in the tube filled with glycerine. Find the velocity of lead shots then using Stoke's law he found the viscosity of the glycerine. The formula used by him was

$$\eta = \frac{2r^2}{9v} (\rho - \sigma)g$$

Answer the following questions (do any four)

- (i) Stokes force does not depend up on
 (a) radius of the object
 (b) viscosity of the medium
 (c) viscosity of the object
 (d) acceleration due to gravity.
- (ii) A steel ball is dropped in glycerine tube of large length, then
 (a) the ball stops after some time
 (b) the speed of ball keeps on increasing
 (c) the ball attains constant velocity after sometime
 (d) none of the above.
- (iii) A sphere of mass 'm' and radius 'r' is falling in one column of glycerine. Terminal velocity attained by falling object is proportional to
 (a) r^2 (b) $\frac{1}{r}$ (c) r (d) $\frac{1}{r^2}$
- (iv) The ratio of terminal velocities of two drops of radii R and $\frac{R}{2}$ is
 (a) 2 (b) 1 (c) $\frac{1}{2}$ (d) 4
- (v) S.I. unit of co-efficient of viscosity is
 (a) poise (b) deca poise (c) dimensionless (d) erg.

Q3. Surface tension is the tendency of fluid surfaces to shrink into the minimum surface area possible. Intermolecular forces such as Van der Waals Force draw the liquid particles together. The ratio of the surface force F to the length L along which the force acts.

$$T = F/L$$

Where,

F is the force per unit length

L is the length in which force act

T is the surface tension of the liquid

ANSWERS

VERY SHORT ANSWERS (1 MARK)

1. This is due to elastic fatigue.
2. Because steel is more elastic than copper as its Young's modulus is more than that of copper.
4. Repeated bending of wire decreases elastic strength and therefore it can be broken easily.
5. $K = \frac{\text{stress}}{\text{strain}} = \frac{\text{stress}}{0} = \infty$ (Infinity)
6. Poisson's ratio is the ratio of lateral strain to the longitudinal strain. It has no units.
7. It is the loss in strength of a material caused due to repeated alternating strains to which the material is subjected.
8. The density of sea water is more than the density of river water, hence sea water gives more up thrust for the same volume of water displaced.
9. This spreads force due to the weight of the train on a larger area and hence reduces the pressure considerably and in turn prevents yielding of the ground under the weight of the train.
10. Pressure exerted by liquid column = hpg so as 'h' increases p increases so to with stand high pressure dams are made thick near the bottom.
11. The atmospheric pressure is low at high altitudes. Due to greater pressure difference in blood pressure and the atmospheric pressure, it is difficult to stop bleeding from a cut in the body.
12. The height of blood column is quite large at feet than at the brain, hence blood pressure at feet is greater.
14. In winter *i.e.*, at low temperature the viscosity of lubricants increases.
15. Due to zero terminal velocity.
16. They have to spread over a large area.
17. Angle of contact increases with increase of temperature while surface tension generally decreases with increase of temperature.
18. Rate of Shear Strain.

19. Viscosity of gases increases while viscosity of liquid decreases.
20. Detergents should have small angle of contact so that they have low surface tension and greater ability to wet a surface. Further as $h = \frac{2T \cos \theta}{r\rho g}$ i.e., θ is small $\cos \theta$ will be large so h i.e., penetration will be high.
21. $[\eta] = [M^1L^{-1}T^{-1}]$
 $[T] = [M^1L^{-2}L^0]$
22. c.g.s unit of η = poise
 S.I. Unit of η = poiseuille or deca poise
 $1 \text{ poise} = 1 \text{ g cm}^{-1} \text{ s}^{-2} = 10^{-1} \text{ kg m}^{-1} \text{ s}^{-1}$
 $= 0.1 \text{ poiseuille}$
23. Viscous force on the parachute is large as $F = 6\pi \eta r v$, $F \propto r$, so its terminal velocity becomes small so the person hits the ground with this small velocity and does not get injured.
24. According to Bernoulli's theorem for horizontal flow $P + \frac{1}{2} \rho v^2 = \text{constant}$.
 As speed of water between the ships is more than outside them pressure between them gets reduced & pressure outside is more so the excess pressure pushes the ships close to each other therefore they get attracted.
25. The molecules in a liquid surface have a net downward force (cohesion) on them, so work done in bringing them from within the body of liquid to the surface increases surface energy.
26. Hot water soap solution has small surface tension therefore can remove the dirt from clothes by wetting them effectively.
27. Mercury does not wet glass because of larger cohesive force between Hg-Hg molecules than the adhesive forces between mercury-glass molecules.
28. When glass is heated, it melts. The surface of this liquid tends to have a minimum area. For a given volume, the surface area is minimum for a sphere. This is why the ends of a glass tube become rounded on heating.
29. The angle of contact between water and the material of the rain coat is obtuse. So the rain water does not wet the rain coat.

30. When a capillary tube of insufficient length is dipped in a liquid, the radius of curvature of the meniscus increase so that $hr = \text{constant}$. That is pressure on concave side becomes equal to pressure exerted by liquid column so liquid does not overflow.
31. No. Unless the atmospheric pressures at the two points where Bernoulli's equation is applied, are significantly different.
34. Volume and electrical resistance.
36. Gas thermometer is more sensitive as coefficient of expansion of Gas is more than mercury.
37. Expansion is always outward, therefore the hole size increased on heating.
38. Ice
39. Infinity
40. The temperature above which molar heat capacity of a solid substance becomes constant.
41. One.
42. At 0K.

43. $E \propto T^4 \therefore \frac{E_2}{E_1} = \left(\frac{T_2}{T_1}\right)^4 = \left(\frac{2T_1}{T_1}\right)^4 = 16$
 $\therefore E_2 = 16 E_1$

44. In conduction and radiation.

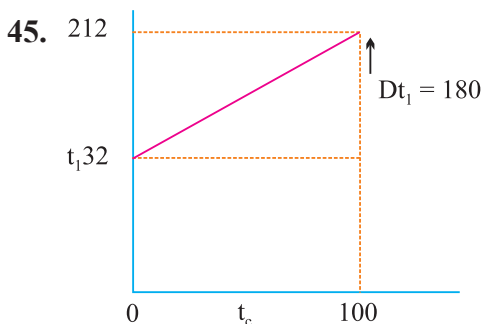

46. When birds swell their feathers, they trap air in the feather. Air being a poor conductor prevents loss of heat and keeps the bird warm.
47. The temp, coefficient of linear expansion for brass is greater than that for steel. On cooling the disc shrinks to a greater extent than the hole, and hence brass disc gets loosened.

SHORT ANSWERS (2 MARKS)

49. Restoring force in extension $x = F = \frac{\Delta Y x}{L}$

Work done in stretching it by $dx = dw = F \cdot dx$

Work done in stretching it from zero to $x = W = \int dw = \int_0^x F dx$

$$W = \int_0^x \frac{\Delta Y x}{L} dx = \frac{1}{2} \frac{\Delta Y x^2}{L}$$

50. Energy Density = $\frac{\text{Energy}}{\text{Volume}} = \frac{\frac{1}{2} \frac{\Delta Y}{L} x^2}{AL}$

$$= \frac{1}{2} \left(\frac{\Delta Y x}{L} \right) \frac{x}{L}$$

$$= \frac{1}{2} \frac{F}{A} \times \frac{x}{L} \quad \left[\because Y = \frac{FL}{Ax} \right]$$

$$= \frac{1}{2} \text{stress} \times \text{strain}$$

53. $Y_s = \frac{F}{A} \frac{L}{\Delta l_s}$

$$Y_r = \frac{F}{A} \frac{L}{\Delta l_r}$$

For same force applied to wires made of steel & rubber of same length and same area of cross section

$$\Delta l_s < \Delta l_r$$

$$\frac{Y_s}{Y_r} = \frac{\Delta l_r}{\Delta l_s} > 1$$

\therefore

$$Y_s > Y_r$$

54. $\Delta l_p = \frac{3mg}{A} \times \frac{L}{Y}$

$$\Delta l_Q = \frac{2mg}{A} \cdot \frac{2L}{Y/2} = \frac{8mg}{A} \frac{L}{Y}$$

$$\therefore \frac{\Delta I_p}{\Delta I_q} = \frac{3}{8}$$

55. Steam at high pressure is made to enter the cylinder of vacuum brake. Due to high velocity, pressure decreases in accordance with Bernoulli's principle. Due to this decrease in pressure, the piston gets lifted. Consequently brake gets lifted.

59. Fig. (a) incorrect.

At the constriction, the area of cross section is small so liquid velocity is large, consequently pressure must be small so height of liquid must be less.

60. The weight supported by (b) and (c) are same as that in (a) and is equal to 4.5×10^{-2} N.

The weight supported = $2 \sigma l$, where σ is surface tension and l is the length which is same in all the three cases, hence weight supported is same.

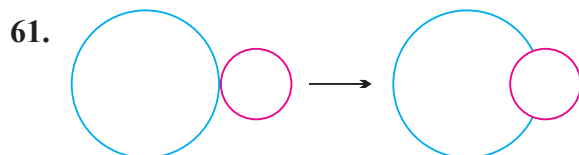

When seen from inside the smaller bubble the common surface will appear $2T$ concave as (1) the pressure (excess) = $\frac{2T}{R}$ will be greater for concave surface & as R is small for the smaller bubble, the pressure will be greater.

62.
$$P_g = \rho gh$$

$$h = \frac{P_g}{\rho g}$$

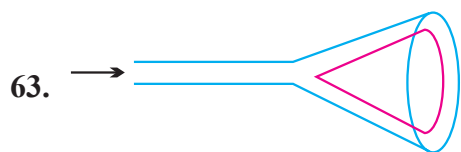

When air is blown into the narrow end its velocity in the region between filter paper and glass increases. This decreases the pressure. The filter paper gets more firmly held with the wall of the tunnel.

64. Glass transmits 50% of heat radiation coming from a hot source like sun but does not allow the radiation from moderately hot bodies to pass through it.

65. We know that $h = \frac{2S \cos \theta}{r\rho g}$

Surface tension of hot water is less than the surface tension of cold water. Moreover, due to thermal expansion the radius of the capillary tube will increase in hot water. Due to both reasons, the height of capillary rise will be less in hot water as compared to cold water.

66. A vapour film is formed between water drop and the hot iron. Vapour being a poor conductor of heat makes the water droplet to evaporate slowly.

67. Due to green house effect, the presence of atmosphere prevents heat radiations received by earth to go back. In the absence of atmosphere radiation will go back at night making the temperature very low and inhospitable.

68. So, that it absorbs more heat with comparatively small change in temperature and extracts large amount of heat.

69. Rate of energy emission is directly proportional to area of surface for a given mass of material. Surface area of sphere is least and that of disc is largest. Therefore cooling of (i) disc is fastest and (ii) sphere is slowest.

70. (a) Time period of pendulum = $T = 2\pi\sqrt{\frac{l}{g}}$ or $T \times \sqrt{l}$

In winter l becomes shorter so its time period reduces so it goes faster. In summer l increases resulting in increase in time period so the clock goes slower.

(b) When the car moves down hill, the decrease in gravitational potential energy is converted into work against force of friction between brake shoe and drum which appears as heat.

71. According to wein's displacement law, $\lambda m t = \text{Constant}$

$$\lambda_1 < \lambda_3 < \lambda_2$$

$$T_1 > T_3 > T_2$$

72. The melting point of ice as well as the boiling point of water changes with change in pressure. The presence of impurities also changes the melting and boiling points. However the triple point of water has a unique temperature and is independent of external factors. It is that temperatures at which water, ice & water vapour co-exist that is 273.16 K and pressure 0.46 cm of Hg.

ANSWERS FOR SHORT QUESTIONS (3 MARKS)

73. The ultimate stress should not exceed elastic limit of steel ($30 \times 10^7 \text{ N/m}^2$)

$$U = \frac{F}{A} = \frac{Mg}{\pi r^2} = \frac{10^5 \times 9.8}{\pi r^2} = 30 \times 10^7$$

$$\therefore r = 3.2 \text{ cm}$$

So to lift a load of 10^4 kg , crane is designed to withstand 10^5 kg . To impart flexibility the rope is made of large number of thin wires braided.

74. (a) Wire with larger plastic region is more ductile material A.

(b) Young's modulus is $\frac{\text{Stress}}{\text{Strain}}$

$$\therefore Y_A > Y_B$$

- (c) For given strain, larger stress is required for A than that for B.

\therefore A is stronger than B.

- (d) Material with smaller plastic region is more brittle, therefore B is more brittle than A.

76. (i) In case (a) Pressure head, $h = + 20 \text{ cm of Hg}$

$$\text{Absolute Pressure} = P + h = 76 + 20 = 96 \text{ cm of Hg.}$$

$$\text{Gauge Pressure} = h = 20 \text{ cm of Hg.}$$

In case (b) Pressure Head $h = - 18 \text{ cm of Hg}$

$$\text{Absolute Pressure} = 76 - 18 = 58 \text{ cm of Hg}$$

$$\text{Gauge Pressure} = h = - 18 \text{ cm of Hg}$$

77. as

$$h_1 p_1 g = h_2 p_2 g$$

$$h_1 \times 13.6 \times g = 13.6 \times 1 \times g$$

$$h_1 = 1 \text{ cm}$$

Therefore as 13.6 cm of H_2O is poured in right limb it will displace Hg level by 1 cm in the left limb, so that difference of levels in the two limbs will become 19 cm.

$$79. \quad v = \frac{2}{9} \left[\frac{g(\sigma - \rho)r^2}{\eta} \right]$$

$$\Rightarrow \quad \frac{v}{r^2} = \frac{2g}{9\eta} (\sigma - \rho) \quad \dots(1)$$

$$\text{Similarly,} \quad \frac{v'}{R^2} = \frac{2g}{9\eta} (\sigma - \rho) \quad \dots(2)$$

Dividing (1) by (2),

$$\frac{v}{v'} = \frac{r^2}{R^2} \Rightarrow v' = v \left(\frac{R}{r} \right)^2$$

If N drops coalesce, then

Volume of one big drop = Volume of N droplets

$$\frac{4}{3} \pi R^3 = N \left(\frac{4}{3} \pi r^3 \right)$$

$$R = N^{1/3} r$$

\therefore Terminal velocity of bigger drop

$$= \left(\frac{R}{r} \right)^2 \times v \text{ from equation (1)}$$

$$= N^{2/3} v \text{ from equation (2)}$$

80. Let P_1 & P_2 be the pressures inside the two bubbles, then

$$P_1 - P = \frac{4T}{r_1} \Rightarrow P_1 = P + \frac{4T}{r_1}$$

$$P_2 - P = \frac{4T}{r_2} \Rightarrow P_2 = P + \frac{4T}{r_2}$$

When bubbles coalesce

$$P_1 V_1 + P_2 V_2 = PV \quad \dots(1)$$

\therefore The pressure inside the new bubble

$$P = P + \frac{4T}{r}$$

Substituting for P , P_1 & P_2 in equation (1)

$$\left(P + \frac{4T}{r_1}\right) \frac{4}{3} \pi r_1^3 + \left(P + \frac{4T}{r_2}\right) \frac{4}{3} \pi r_2^3 = \left(P + \frac{4T}{r}\right) \frac{4}{3} \pi r^3$$

or $\frac{4}{3} \pi P (r_1^3 + r_2^3 - r^3) + \frac{16\pi T}{3} [r_1^2 + r_2^2 - r^2] = 0$

Given change in volume,

$$V = \frac{4}{3} \pi r_1^3 + \frac{4}{3} \pi r_2^3 - \frac{4}{3} \pi r^3 \quad \dots(3)$$

Change in Area

$$4\pi r_1^2 + 4\pi r_2^2 - 4\pi r^2 \quad \dots(4)$$

Using equation (3) and (4) in (2), we get

$$PV + \frac{4T}{3} A = 3PV + 4TA = 0$$

82. Free block diagram of balloon and block shown below :

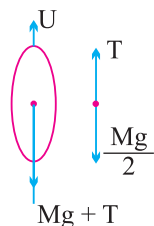

When the balloon is held stationary in air, the forces acting on it get balance

$$U_{\text{p thrust}} = \text{Wt. of Balloon} + \text{Tension in string}$$

$$U = Mg + T$$

M for the small block of mass $\frac{M}{2}$ floating stationary in air

$$T = \frac{M}{2} g$$

$$\therefore U = Mg + \frac{M}{2} g = \frac{3}{2} Mg$$

When the string is cut $T = 0$, the small block begins to fall freely, the balloon rises up with an acceleration 'a' such that

$$U - Mg = Ma$$

$$\frac{3}{2}Mg - Mg = Ma$$

$$a = \frac{g}{2} \text{ in the upward direction.}$$

83. (i) As the two vessels have liquid to same height and the vessels have same base area, the force exerted = pressure \times base area will be same as pressure

$$= h p g.$$

- (ii) Since the volume of water in vessel 1 is greater than in vessel (2) the weight of water = volume \times density $\times h$, so weight of first vessel will be greater than the water in second vessel.

84. Radius of larger drop = $\frac{D}{2}$

Radius of each small drop = r

$$27 \times \frac{4}{3} \pi r^3 = \frac{4}{3} \pi \left(\frac{D}{2} \right)^3 \Rightarrow r = \frac{D}{6}$$

Initial surface area of large drop $4\pi \left(\frac{D}{2} \right)^2 = \pi D^2$

Final surface area of 27 small drop

$$= 27 \times 4\pi r^2 = 27 \times 4\pi \frac{D^2}{36} = 3\pi D^2$$

\therefore Change in energy = Increase in area $\times \sigma$
 $= 2\pi D^2 \sigma$

87. $I_1^1 = I_1 [1 + \alpha_1 (t_2 - t_1)]$

$$I_2^1 = I_2 [1 + \alpha_2 (t_2 - t_1)]$$

Given that the difference in their length remain constant

$\therefore I_2^1 - I_1^1 = I_2 - I_1$

$$I_2 [1 + \alpha_2 (t_2 - t_1)] - I_1 [1 + \alpha_1 (t_2 - t_1)] = I_2 - I_1$$

$\therefore I_2 \alpha_2 = I_1 \alpha_1$

90. Here

$$l = 1.8 \text{ m}, t_1 = 27^\circ\text{C}, t_2 = -39^\circ\text{C}$$

$$r = \frac{2.0}{2} = 1.0 \text{ mm} = 1.0 \times 10^{-3} \text{ m}$$

$$r = 2.0 \times 10^{-5} \text{ }^\circ\text{C}^{-1}, Y = 0.91 \times 10^{11} \text{ Pa}$$

As $\Delta l = l \alpha (t_2 - t_1)$

\therefore Strain, $\frac{\Delta l}{l} = \alpha (t_2 - t_1)$

Stress = Strain \times Young's modulus = $\alpha (t_2 - t_1) \times Y$

$$= 2.0 \times 10^{-5} \times (-39 - 27) \times 0.91 \times 10^{11} = 1.2 \times 10^8 \text{ Nm}^{-2}$$

[Numerically]

Tension developed in the wire = Stress \times Area of cross-section

$$= \text{Stress} \times \pi r^2 = 1.2 \times 10^8 \times 3.14 \times (1.0 \times 10^{-3})^2 = 3.77 \times 10^2 \text{ N}.$$

96. Definition of coefficient of thermal conductivity.

In steady state the heat passing in unit time through the rod remain same that is

$$\frac{Q}{t} = \frac{K_1 A (T_1 - T)}{d_1} = \frac{K_2 A (T - T_2)}{d_2} = \frac{K A (T_1 - T_2)}{d_1 + d_2}$$

where k is the coefficient of thermal conductivity

Also $T_1 - T_2 = (T_1 - T) + (T - T_2)$

$$\therefore \frac{d_1 + d_2}{kA} = \frac{d_1}{K_1 A} + \frac{d_2}{K_2 A}$$

$$\therefore \frac{d_1 + d_2}{kA} = \frac{d_1}{K_1} + \frac{d_2}{K_2} = \frac{K_2 d_1 + K_1 d_2}{K_1 K_2}$$

$$\therefore K = \frac{K_1 K_2 (d_1 + d_2)}{K_2 d_1 + K_1 d_2}$$

ANSWERS FOR NUMERICALS

106. (a) $\text{Stress} = \frac{F}{A} = \frac{mg}{\pi r^2} = \frac{40 \times 10}{\pi \times (1 \times 10^{-3})^2} = 1.27 \times 10^8 \text{ N/m}^2$

(b) $\Delta L = \frac{FL}{AY} = \frac{40 \times 10 \times 1}{\pi \times (1 \times 10^{-3})^2 \times 7 \times 10^{10}} = 1.8 \times 10^{-3} \text{ m}$

(c) $\text{Strain} = \frac{\Delta L}{L} = \frac{1.8 \times 10^{-3}}{1} = 1.8 \times 10^{-3}$

(d) $F = Kx = K\Delta L$, $K = \text{Force constant}$

$$K = \frac{\Delta F}{L} = \frac{40 \times 10}{1.8 \times 10^{-3}} = 2.2 \times 10^5 \text{ N/m}$$

107. Pressure exerted at the bottom layer by water column of height h is

$$P = h\rho g = 2500 \times 1000 \times 10$$

$$= 2.5 \times 10^7 \text{ N/m}^2$$

$$= \text{Stress}$$

Bulk modulus $K = \frac{\text{Stress}}{\text{Strain}} = \frac{P}{\Delta V/V}$

$$\frac{\Delta V}{V} = \frac{P}{K} = \frac{2.5 \times 10^7}{2.3 \times 10^9} = 1.08 \times 10^{-2}$$

$$= 1.08\%$$

108. Area A of the upper face = $(0.30)^2 \text{ m}^2$

The displacement Δx of the upper face relative to the lower one is given by

$$\Delta x = \frac{yF}{\eta A}, \quad \therefore \eta = \frac{F/A}{\Delta x/y}$$

$$\frac{0.30 \times 5 \times 10^3}{8.3 \times 10^{10} \times (0.30)^2} = 2 \times 10^{-7} \text{ m}$$

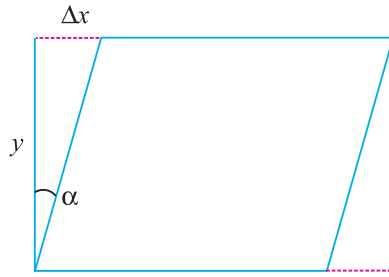

∴ Angle of shear α is given by

$$\tan \alpha = \frac{\Delta x}{y}$$

$$\begin{aligned} \alpha &= \tan^{-1} \left(\frac{\Delta x}{y} \right) \\ &= \tan^{-1} \left(\frac{2 \times 10^{-7}}{0.30} \right) = \tan^{-1} (0.67 \times 10^{-6}) \end{aligned}$$

109.

$$V = 1 \text{ litre} = 10^{-3} \text{ m}^3$$

$$\frac{\Delta V}{V} = 0.10\% = \frac{0.10}{100} = 0.001$$

$$K = \frac{P}{\Delta V/V} \Rightarrow P = \frac{K \Delta V}{V} = 2.2 \times 10^9 \times 0.001$$

$$P = 2.2 \times 10^6 \text{ Nm}^{-2}$$

110. Pressure at a depth of 10 m = $h\rho g$

$$= 10 \times 1030 \times 10 = 1.03 \times 10^5 \text{ N/m}^2$$

$$\text{ATM. pressure} = 1.01 \times 10^5 \text{ pa.}$$

$$\text{Total pressure at a depth of 10 m} = 1.03 \times 10^5 + 1.01 \times 10^5$$

$$= 2.04 \times 10^5 \text{ pa}$$

111.

$$\frac{F_1}{A_1} = \frac{F_2}{A_2}$$

$$F_1 = F_2 \frac{A_1}{A_2} = F_2 \left(\frac{\pi r_1^2}{\pi r_2^2} \right)$$

$$F_1 = 1350 \times 9.8 \left(\frac{5 \times 10^{-2}}{15 \times 10^{-2}} \right)^2$$

$$= 1470 \text{ N.}$$

112. (i) When man is lying $P = \frac{F}{A} = \frac{80 \times 9.8}{0.6} = 1.307 \times 10^3 \text{ N/m}^{-2}$

(ii) When man is standing then $A = 2 \times 80 \text{ cm}^2 = 160 \times 10^{-4} \text{ m}^2$

$$P = \frac{80 \times 9.8}{160 \times 10^{-4}} = 4.9 \times 10^4 \text{ Nm}^{-2}$$

113. (a) Pressure Instructed by manual = $P_g = 200 \text{ k P}_a$

(b) Absolute Pressure = $101 \text{ k P}_a + 200 \text{ k P}_a = 301 \text{ k P}_a$

(c) At mountain Peak P_a' is 10% less

$$P_a' = 90 \text{ k P}_a$$

If we assume absolute pressure in tyre does not change during driving then

$$P_g = P - P_a' = 301 - 30 = 211 \text{ k P}_a$$

So the tyre will read 211 k P_a , pressure.

114. Excess pressure in soap bubble = $p = \frac{4\Gamma}{r} = \left(\frac{4 \times 0.58}{6 \times 10^{-3}} \right)$

$$= 387 \text{ Nm}^{-2}$$

115.

$$v_t = \frac{2}{9} \left[\frac{g(\sigma - \rho)r^2}{\eta} \right]$$

$$\eta = \frac{2}{9} \left[\frac{9.8 \times (8.9 \times 10^3 - 1.5 \times 10^3)(2 \times 10^{-3})^2}{6 \times 10^{-2}} \right]$$

$$= 1.08 \text{ kg m}^{-1} \text{ s}^{-1}$$

116. From Torricelli theorem, velocity of efflux

$$v = \sqrt{2gh}$$

$$= \sqrt{2 \times 10 \times 0.2}$$

$$= 2 \text{ m/s}$$

117. Surface energy per unit area is equal to surface tension.

$$\begin{aligned} E &= \text{increase in surface area} \times ST \\ &= 4\pi (2^2 - 1^2) \times 2.5 \\ &= 4\pi \times 3 \times 2.5 \\ &= 1.02 \times 10^3 \text{ erg} \end{aligned}$$

118.

$$\begin{aligned} F &= \eta A \frac{dv}{dy} \\ &= 0.01 \times 0.2 \times \frac{0.1}{0.003} = 66.7 \times 10^{-3} \text{ N} \end{aligned}$$

119. Since

$$A_1 v_1 = A_2 v_2$$

$$v_2 = \frac{2 \times 4 \times 10^{-4}}{2 \times 10^{-4}} = 4 \text{ m/s}$$

Using Bernoulli's Theorem

$$P_2 = P_1 + \frac{1}{2} \rho (v_1^2 - v_2^2) + \rho g (h_1 - h_2)$$

\therefore

$$v_2 > v_1$$

$$h_2 > h_1$$

$$= 3 \times 10^5 + \frac{1}{2} (1000) [(2)^2 - (4)^2] - 1000 \times 9.8 \times 8$$

$$= 2.16 \times 10^5 \text{ N/m}^2$$

120. The volume of liquid flowing in time t through a capillary tube is given by

$$V = Qt = \frac{\pi Pr^4 t}{8\eta l} = \frac{\pi h \rho g r^4 t}{8\eta l}$$

$$\therefore \text{For Water,} \quad V_1 = \frac{\pi h \rho_1 g r^4 t_1}{8\eta_1}$$

$$\text{For Petrol,} \quad V_2 = \frac{\pi h \rho_2 g r^4 t_2}{8\eta_2}$$

$$\text{But} \quad V_1 = V_2$$

$$\therefore \quad \frac{\pi h \rho_1 g r^4 t_1}{8\eta_1} = \frac{\pi h \rho_2 g r^4 t_2}{8\eta_2}$$

or
$$\frac{t_1}{t_2} = \frac{\eta_1}{\eta_2} \times \frac{\rho_1}{\rho_2} = \frac{0.01}{0.02} \times \frac{0.8}{0.02} = 0.4$$

121. Breaking stress = Maximum stress that the wire can withstand

$$= 7.8 \times 10^9 \text{ Nm}^{-2}$$

When the wire is suspended vertically, it tends to break under its own weight.

Let its length be l and cross-sectional area A .

$$\text{Weight of wire} = mg = \text{volume} \times \text{density} \times g = A l \rho g$$

$$\text{Stress} = \frac{\text{Weight}}{A} = A l \rho g / A = l \rho g$$

For the wire not to break, $l \rho g = \text{Breaking stress} = 7.8 \times 10^9 \text{ Nm}^{-2}$

$$\therefore l = \frac{7.8 \times 10^9}{\rho g} = \frac{7.8 \times 10^9}{7.8 \times 10^3 \times 10} = 10^5 \text{ m.}$$

122. By Wein's Displacement Law

$$\lambda_m T = \lambda'_m T'$$

$$\frac{T}{T'} = \frac{\lambda'_m}{\lambda_m} = \frac{4.8 \times 10^{-7}}{3.6 \times 10^{-7}}$$

$$= \frac{4}{3}$$

123.
$$\frac{F - 32}{180} = \frac{T - 273}{100}$$

$$\frac{149 - 32}{180} = \frac{T - 273}{100} \Rightarrow \frac{117}{9} = T - 273$$

$$T = 286 \text{ K}$$

124.
$$m_1 c_1 (\theta_1 - \theta) = m_2 c_2 (\theta - \theta_2)$$

$$\therefore c_2 = 1 \text{ cal/gm}^\circ\text{C}$$

$$\therefore 50 \times 0.6 \times (120 - \theta) = 1.6 \times 10^3 \times 1 \times (\theta - 25)$$

$$\theta = 26.8^\circ\text{C}$$

125.

$$d_2 = d_1 [1 + \alpha \Delta t]$$

$$5.243 = 5.231 [1 + 1.2 \times 10^{-5} (T - 30)]$$

$$\left[\frac{5243}{5231} - 1 \right] = 1.2 \times 10^{-5} (T - 300)$$

$$T = 191 + 300 = 491 \text{ K} = 218^\circ\text{C}$$

126. ice at 0°C \rightarrow water at 0°C \rightarrow water at 6°C

$$m_1 c_1 (80 - 6) = m_2 L + m_2 c_2 (6 - 0)$$

$$100 \times 1 \times 74 = 100 L + 100 \times 1 \times 6$$

$$L = (1 \times 74) - 6$$

$$= 68 \text{ cal/g.}$$

127. Heat required to convert H_2O at 0° to H_2O at $100^\circ = m_1 c_1 t$

$$= 30 \times 4186 \times 100$$

$$= 1255800 \text{ J}$$

Heat required to convert H_2O at 100°C to steam at 100°C is = mL

$$= 3 \times 2.256 \times 10^6$$

$$= 6768000 \text{ J}$$

$$\text{Total heat} = 8023800 \text{ J}$$

128.

$$\text{Thermal stress} = K \times \text{strain} = \frac{K \Delta V}{V}$$

Now, $\gamma = \frac{\Delta V}{V \Delta T}$ or $\frac{\Delta V}{V} = \gamma \Delta T$

$$\text{Thermal stress} = K \gamma \Delta T = 3K \alpha \Delta T \quad [\because \gamma = 3\alpha]$$

$$= 3 \times 140 \times 10^9 \times 1.7 \times 10^{-5} \times 20$$

$$= 1.428 \times 10^8 \text{ Nm}^2$$

HINTS AND SOLUTION (MCQ)

131. (c) Longitudinal & shear.

132. (d) Breaking force = breaking stress \times area of cross section of wire ie it is independent of length of its wire till area of cross-section of wire is constant.

133. (b)

$$Y = \frac{F}{\pi \left(\frac{D}{2}\right)^2} \times \frac{1}{\left(\frac{\Delta \ell}{\ell}\right)} = \frac{4F\ell}{\pi D^2 \Delta \ell}$$

$$\Rightarrow D = \sqrt{\frac{4F\ell}{\pi \Delta \ell Y}} \quad \text{or} \quad D \propto \sqrt{\frac{1}{Y}}$$

$$\text{Hence } \frac{D_{\text{copper}}}{D_{\text{iron}}} = \sqrt{\frac{Y_{\text{iron}}}{Y_{\text{copper}}}}$$

134. (a) Increase in length = Bo + OC - BC

$$\text{or } \Delta L = 2B0 - 2L$$

$$\Delta L = 2(L^2 + x^2)^{1/2} - 2L$$

$$\Delta L = 2L \left[1 + \frac{x^2}{L^2} \right]^{1/2} - 2L$$

$$\Delta = \frac{\Delta L}{L} = \frac{2L \left[1 + \frac{x^2}{L^2} \right]^{1/2} - 2L}{L}$$

$$\text{So strain} = \frac{\Delta L}{2L} = \frac{x^2}{L \times 2L} = \frac{x^2}{2L^2}$$

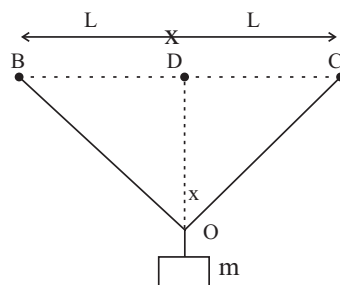

135.(a&d) Ideal liquid does not compress easily $\Delta V = 0$ so β & α . A liquid cannot sustain tangential force i.e. strain is infinite for a shear stress Hence $G = 0$.

136.(c&d) From graph it is clear that ultimate strength of the material (ii) is greater than that of material (i). Therefore the elastic behaviour of material (ii) is over a larger region of strains as compared to material (i).

If the fracting point E is closer to ultimate strength point, than the material is brittle.

137. (c) When a round pebble is dropped from the top of a tall cylinder, filled with viscous oil the pebble acquires terminal velocity after some time. Hence option (c) correct.

138. (a) According to Equation of continuity

$$a_1 v_1 = a_2 v_2$$

or

$$\frac{v_1}{v_2} = \frac{a_2}{a_1} = \frac{\pi d_2^2 / 4}{\pi d_1^2 / 4} = \left(\frac{d_2}{d_1}\right)^2 = \left(\frac{13.75}{2.5}\right)^2 = \frac{9}{4}$$

139. (c) Meniscus is convex upwards if angle contact is obtuse.

140. (d) Give $\alpha_{Al} > \alpha_{steel}$ so on heating aluminum strip will expand more than that of steel strip. So aluminum strip will bend more on convex side & steel strip on concave side.

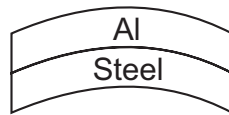

141. (b) When a metallic rod is heated it expands. Its M.I about perpendicular bisector increases. So according to Law of conservation of angular Momentum, its angular speed (ω) decrease. as $I_1 \omega_1 = I_2 \omega_2$.

142. (a) With increase in temperature; the effective length (ℓ) of the simple pendulum increases even though its CM still remains at the centre of bob. So As $T = 2\pi\sqrt{\frac{\ell}{g}}$ or $T \propto \sqrt{\ell}$ so T increases as temperature increase.

143.(a&d) In the given graph, the region AB represents no change the temperature with time. It means ICE & water are in thermal equilibrium.

144. (c) From 1st observation :

$$\alpha = \frac{\Delta \ell}{\ell \Delta T} = \frac{4 \times 16^{-4}}{2 \times 10} = 2 \times 10^{-5} \text{ } ^\circ\text{C}^{-1}$$

So From 2nd observation $= \Delta \ell = \alpha \ell \Delta T = (2 \times 10^{-5}) \times 1 \times 10 = 2 \times 10^{-4} \text{ m (Incorrect)}$

From 3rd observation $= \Delta \ell = \alpha \ell \Delta T = (2 \times 10^{-5}) \times 2 \times 20 = 8 \times 10^{-4} \text{ m (Incorrect)}$

From 4th observation $= \Delta \ell = \alpha \ell \Delta T = (2 \times 10^{-5}) \times 3 \times 10 = 6 \times 10^{-4} \text{ m (Correct)}$

145. (b) $B = \frac{P}{(\Delta v/v)}$ or $\frac{\Delta v}{v} = \frac{P}{B}$

$$\frac{\Delta v}{v} = h\rho g \times K \quad \text{as } p = h\rho g, \quad B = \frac{1}{K}$$

$$\frac{\Delta v}{v} = 2700 \times 10^3 \times 9.8 \times 45.4 \times 10^{-11}$$

$$= 1.2 \times 10^{-2}$$

146. (c) Here $Y_S = 2Y_B$, $\frac{Y_S}{Y_B} = \frac{2}{1}$

Let W_S & W_B the weights hanged to steel & brass wires

$$\ell_S = \ell_B = \ell; \quad A_B = A_S = A, \quad \Delta\ell_S = \Delta\ell_B = \Delta\ell$$

$$Y = \frac{W\ell}{A\Delta\ell} \quad \text{or} \quad \Delta\ell = \frac{W\ell}{AY}$$

as $\Delta\ell_S = \Delta\ell_B$

$$\therefore \frac{W_S \ell}{AY_S} = \frac{W_B \ell}{AY_B}$$

$$\frac{W_S}{W_B} = \frac{Y_B}{Y_S} = \frac{2}{1}$$

147. (c) Expansion in the rod due to rise in temp = Compression in rod.

For the first rod $\Delta\ell_1 = \alpha_1 \ell_1 \Delta\theta$

$$\text{Compression in the rod } \Delta\ell_1 = \frac{-F}{A} \frac{\ell_1}{Y_1}$$

or the length of the rod remains unchanged

$$\alpha_1 \ell_1 \Delta\theta = \frac{-F \ell_1}{A Y_1}$$

or

$$\alpha_1 \Delta\theta = \frac{-F}{A Y_1} \quad \text{---- (i)}$$

Similarly for second rod

$$\alpha_2 \Delta\theta = \frac{-F}{A Y_2} \quad \text{---- (ii)}$$

$$\frac{\alpha_1}{\alpha_2} = \frac{Y_2}{Y_1} \quad \text{or} \quad \frac{Y_1}{Y_2} = \frac{\alpha_2}{\alpha_1} = \frac{3}{2}$$

148. (a) As slope of the graph \propto Young's Modulus

149. (c) As we know $\frac{d\theta}{dt} \propto (T_2 - T_1)$ or $\frac{d\theta}{dt} = K(T_2 - T_1)$

$$\text{Case (i)} \quad \frac{d\theta_1}{dt} = k(110 - 100) = k \times 10 \quad \text{--- (i)}$$

$$\text{Case (ii)} \quad \frac{d\theta_2}{dt} = k(210 - 200) = k \times 10 \quad \text{--- (ii)}$$

$$\text{From (i) \& (ii)} \quad \frac{d\theta_1}{dt} = \frac{d\theta_2}{dt} = 4.0 \text{ J/s}$$

150. (d) Heat gain by water = heat loss by steam

$$20 \times 1 \times (80 - 100) = m \times 540 + m \times 1 \times (100 - 80)$$

$$1400 = 560 m$$

$$m = \frac{1400}{560} = 2.5 \text{ g}$$

$$\text{Total mass of water} = 20 + 2.5 = 22.5 \text{ g}$$

ASSERTION - REASON BASED ANSWERS

- | | | | | | |
|---------|---------|---------|---------|---------|---------|
| 1. (b) | 2. (b) | 3. (d) | 4. (b) | 5. (a) | 6. (a) |
| 7. (a) | 8. (a) | 9. (a) | 10. (c) | 11. (a) | 12. (a) |
| 13. (b) | 14. (a) | 15. (a) | 16. (c) | 17. (a) | 18. (a) |

SOLUTION

- (b) The size of balloon increase because outside pressure is extremely low at high altitudes. So volume increases, but reason is not the correct explanation of assertion.
- (b) Both are true but reason is not correct explanation of the assertion.
- (d) An ideal rigid body with definite and unchanging shape.
- (b) In gases, sound waves are always longitudinal because gases cannot sustain shearing strain.
- (a) In rigid body size and shape of the body remains same.

6. (a) both statements are true.
7. (a) both statements are true.
8. (a) due to alternating strains, it loses its elastic strength. Due to which the amount of strain in the bridge for given stress becomes large and ultimately, the bridge may collapse.
9. (a) $y = \frac{\text{stress}}{\text{strain}}$, $\text{stress} = \frac{\text{restoring force}}{\text{area}}$
 As restoring force is zero. i.e. $y = 0$
10. (c) Strain is the ratio of change in dimensions of the body to the original dimensions. Because this is a ratio, therefore it is dimensionless quantity.
11. (a) Height of the blood column in the human body is more at feet than the brain as $p = h\rho g$, therefore the blood exerts more pressure at the feet than at the brain.
12. (a) In stream line flow of a liquid, according to equation of continuity, $av = \text{constant}$, where 'a' is area of cross-section and 'v' is velocity. So, as area of cross-section decreases, therefore the velocity 'u' of water increases.
13. (b) As a man jumps out from a height in air with a parachute, its velocity increases first because the gravity pull dominates the viscous drag and buoyancy of air which opposes the motion. As the velocity increases, the viscous drag of air also increases and soon a stage is reached where viscous drag and buoyancy of air balances the gravity pull. Then the man with a parachute falls with constant velocity called terminal velocity.
14. (a) According to Bernoulli's theorem, $P + \frac{1}{2}\rho v^2 = \text{constant}$.
 i.e. when velocity is large, the pressure is less in a stream line flow of an ideal fluid through a horizontal tube.
15. (a)
16. (c) When two holes are made in the tin, air keeps on entering through the other hole. Due to this pressure inside the tin does not become less than atmospheric pressure which happens if only one hole is made.
17. (a)

18. (a) The height of capillary rise is inversely proportional to radius of capillary tube i.e. $h \propto \frac{1}{r}$
So for smaller 'r' the value of 'h' is higher.

CASE STUDY BASED ANSWERS

1. i. (d)
ii. (b)
iii. (d)
iv. (d)
v. (c)
2. i. (d)
ii. (c)
iii. (a)
iv. (d)
v. (b)
3. i. (c)
ii. (d)
iii. (b)
iv. (a)
v. (b)

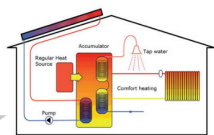

Unit - 8

Thermodynamics

THERMOMETRY, THERMAL EXPANSION AND CALORIMETRY

8.1 Heat

The energy associated with configuration and random motion of the atoms and molecules with in a body is called heat.

- (1) Units : Joule (S.I.) and calorie (Practical unit)
- (2) The ratio of work done (W) to heat produced (Q) is constant.

$$\frac{W}{Q} = J \text{ or } W = JQ$$

J is called mechanical equivalent of heat and has value 4.2 J/cal.

$$1 \text{ calorie} = 4.186 \text{ Joule} = 4.2 \text{ J}$$

- (3) Heat is a path dependent and is taken to be positive if the system absorbs it and negative if releases it.

8.2 Temperature

Temperature is defined as the degree of hotness or coldness of a body. Heat flows from higher temperature to lower temperature.

Two bodies are said to be in thermal equilibrium when both the bodies are

at the same temperature. Temperature \propto kinetic energy $\left[\text{As } E = \frac{3}{2} RT \right]$

8.3 Scales of Temperature

The Kelvin temperature scale is also known as thermodynamic scale. The S.I. unit of temperature is kelvin and is defined as (1/273.16) of the temperature of the triple point of water. The triple point of water is that point on a P–T diagram where the three phases of water, the solid, the liquid and the gas,

can coexist in thermal equilibrium.

To construct a scale of temperature, two fixed points are taken. First is the freezing point of water, it is called lower fixed point. The second is the boiling point of water, it is called upper fixed point.

Name of the scale	Symbol for each degree	Lower fixed point (LFP)	Upper fixed point (UFP)	Number of divisions on the scale
Celsius	°C	0°C	100°C	100
Fahrenheit	°F	32°F	212°F	180
Reaumer	°R	0°R	80°R	80
Rankine	°Ra	460 Ra	672 Ra	212
Kelvin	K	273.15 K	373.15 K	100

Temperature on one scale can be converted into other scale by using the following identity.

$$\frac{\text{Reading on any scale} - \text{Lower fixed point (LFP)}}{\text{Upper fixed point (UFP)} - \text{Lower fixed point (LFP)}} = \text{Constant for all scales}$$

8.4 Thermal Expansion

When matter is heated, it expands.

(i) Coefficient of linear expansion $\alpha = \frac{\Delta L}{L} \times \frac{1}{\Delta T}$

(ii) Coefficient of superficial expansion $\beta = \frac{\Delta A}{A} \times \frac{1}{\Delta T}$

(iii) Coefficient of volume expansion $\gamma = \frac{\Delta V}{V} \times \frac{1}{\Delta T}$

(iv) The value of α , β and γ depends upon the nature of material. All have dimension $[\theta^{-1}]$ and unit per °C.

(v) $\Delta L = L\alpha\Delta T$, $\Delta A = A\beta\Delta T$ and $\Delta V = V\gamma\Delta T$

(vi) Final length $L' = L + \Delta L = L(1 + \alpha\Delta T)$

Final area $A' = A + \Delta A = A(1 + \beta\Delta T)$

Final volume $V' = V + \Delta V = V (1 + \gamma \Delta T)$

(vii) $\beta = 2 \alpha$ and $\gamma = 3 \alpha$

8.5 Anomalous Expansion of Water

- (1) In case of water, it expands on heating if its temperature is greater than 4°C. In the range 0°C to 4°C water contracts on heating and expands on cooling, *i.e.*, negative.

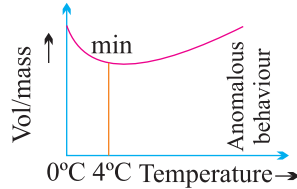

- (2) At 4°C, density of water is maximum while its specific volume is minimum.

8.6 Expansion of Gases

Gases have no definite shape, therefore gases have only volume expansion.

8.7 Thermal Capacity and Water Equivalent

- (1) **Thermal capacity** : It is defined as the amount of heat required to raise the temperature of the whole body (mass, m) through 1°C or 1 K.

$$\text{Thermal capacity} = m c = \mu C = \frac{Q}{\Delta T}$$

Dimension : $[ML^2T^{-2}\theta^{-1}]$, Unit : call °C (practical) Joule K (S.I.)

- (2) **Water Equivalent** : Water equivalent of a body is defined as the mass of water which would absorb or evolve the same amount of heat as is done by the body in rising or falling through the same range of temperature. It is represented by W .

If m = Mass of the body, c = Specific heat of body

$$\therefore \text{Water equivalent (W)} = mc \text{ gm}$$

8.8 Specific Heat

- (1) **Gram specific heat** : The heat required to raise the temperature of one gram mass of a body through 1°C (or 1 K) is called gram specific heat of the material of the body.

$$\text{specific heat, } c = \frac{Q}{m\Delta T}$$

Units : Calorie/ $gm^{\circ}C$ (Practical), J/kg K(S.I.)

Dimension : $[L^2T^{-2}\theta^{-1}]$

- (2) **Molar specific heat** : Amount of heat required to raise the temperature of one gram mole of the substance through a unit degree it is represented by (capital) C.

$$\therefore C = \frac{Q}{\mu\Delta T}$$

Units : Cal $\text{mol}^{-1} \text{ }^{\circ}C^{-1}$ (Practical), J $\text{mol}^{-1} \text{ K}^{-1}$ (S.I.)

Dimension : $[ML^2T^{-2}\theta^{-1}\mu^{-1}]$

8.9 Specific Heat of Solids

Specific heat of a solid is specific heat at constant volume C_v .

With rise in temperature, C_v increases and becomes constant = $3R$

Dulong and Petit law : Average molar specific heat of all metals at room temperature is constant and is equal to $3R$. This statement is known as Dulong and Petit law.

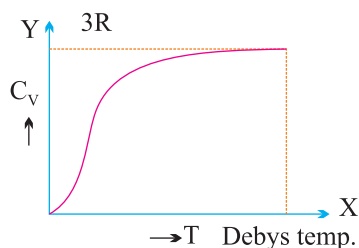

8.10 Latent Heat

- (1) When a substance changes from one state to another state then energy is either absorbed or liberated. This heat energy is called latent heat.
- (2) No change in temperature is involved when the substance changes its state.
- (3) $\Delta Q = mL$, where L is the latent heat.
- (4) Unit : cal/gm or J/kg and Dimension : $[L^2T^{-2}]$
- (5) Any material has two types of latent heats
 - (i) **Latent heat of fusion** : The heat required to change 1 kg of the material in its solid state to its liquid state, latent heat of fusion (or latent heat of ice) is $L_F = L_{ice} \approx 80 \text{ cal/g}$.

- (ii) **Latent heat of vaporisation** : The heat energy required to change 1 kg of the material in its liquid to 1 kg of the material in its gaseous state. Latent heat of vaporisation (latent heat of steam) is $L_v = L_{\text{steam}} \approx 540 \text{ cal/gm}$.

8.11 Principle of Calorimetry

Heat lost = Heat gained

i.e., principle of calorimetry represents the law of conservation of heat energy.

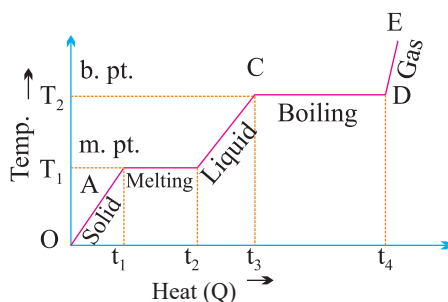

8.12 Heating Curve

Thermodynamic Processes

- (1) **Thermodynamics** : It is a branch of science which deals with exchange of heat energy between bodies and conversion of the heat energy into mechanical energy and vice versa.
- (2) **Thermodynamic system** : A collection of an extremely large number of atoms or molecules confined within certain boundaries such that it has a certain value of pressure, volume and temperature is called a thermodynamic system. Anything outside the thermodynamic system to which energy or matter is exchanged is called its surroundings.

Thermodynamic system may be of three types :

- (i) **Open system** : It exchange both energy and matter with the surrounding.
- (ii) **Closed system** : It exchange only energy (not matter) with the surroundings.
- (iii) **Isolated system** : It exchange neither energy nor matter with the surrounding.

- (3) **Thermodynamic variables and equation of state :** Pressure, volume, temperature, internal energy and the number of moles are called thermodynamic variables.

For μ moles of an ideal gas, equation of state is $PV = \mu RT$.

Thermodynamic State Variables :

- (i) Intensive variables
- (ii) Extensive variables.

8.13 Zeroth Law of Thermodynamics

If systems A and B are each in thermal equilibrium with a third system separately C, then A and B are in thermal equilibrium with each other.

The zeroth law leads to the concept of temperature.

8.14 Quantities Involved in First Law of Thermodynamics

- (1) **Heat (ΔQ) :** It is the energy that is transferred between a system and its environment.

- (i) Heat is a form of energy so it is a scalar quantity with dimension $[ML^2T^{-2}]$.
- (ii) Unit : Joule (S.I.), Calorie (1 calorie = 4.2 Joule)
- (iii) Heat is a path dependent quantity.
- (iv) $\Delta Q = mL$ [For change in state] and $\Delta Q = mc\Delta T$ [For change in temperature]

$(\Delta Q)_V = \mu C_V \Delta T$ [For constant volume] and $(\Delta Q)_P = \mu C_P \Delta T$ [For constant pressure]

- (2) **Work (ΔW) :**

$$\therefore \text{Work done } \Delta W = \int dW = \int_{V_i}^{V_f} p dV = P(V_f - V_i)$$

- (i) Like heat, work is also a path dependent, scalar physical quantity with dimension $[ML^2T^{-2}]$
- (ii) $\Delta W =$ positive if $V_f > V_i$ i.e., system expands
 $\Delta W =$ negative if $V_f < V_i$ i.e., system contracts

(iii) $W = \text{area under } P - V \text{ diagram}$

It is positive if volume increases (for expansion)

It is negative if volume decreases (for compression)

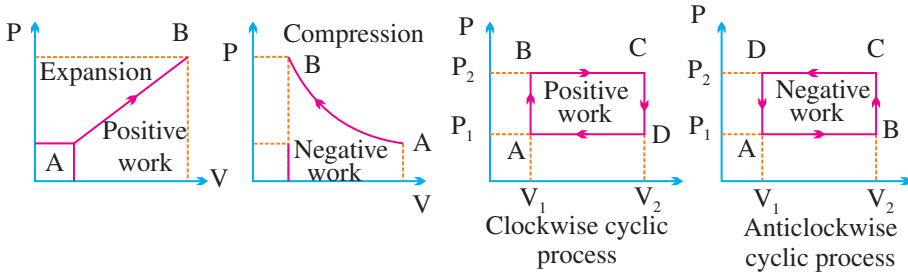

It is positive if the cycle is clockwise.

It is negative if the cycle is anticlockwise.

(3) Internal energy (U) : Internal energy of a system is the energy due to molecular motion and molecular configuration.

The energy due to molecular motion is called internal kinetic energy U_k and that due to molecular configuration is called internal potential energy U_p .

i.e., Total internal energy $U = U_k + U_p$

(i) Internal energy of an ideal gas is totally kinetic $U = U_k = \frac{3}{2} \mu RT$

(ii) In case of gases whatever be the process

$$\Delta U = \int P \, dV$$

(iii) Change in internal energy does not depend on the path.

$$\Delta U = U_f - U_i$$

(iv) Change in internal energy in a cyclic process is always zero.

8.15 First Law of Thermodynamics

It is a statement of conservation of energy. According to it $\Delta Q = \Delta U + \Delta W$

(1) First law introduces the concept of internal energy.

(2) Sign conventions

ΔQ	Positive	When heat is supplied to a system
	Negative	When heat is drawn from the system
ΔW	Positive	When work done by the gas (expansion)
	Negative	When work done on the gas (compression)
ΔU	Positive	When temperature increases, internal energy increases
	Negative	When temperature decreases, internal energy decreases

(3) **Limitation** : First law of thermodynamics does not indicate the direction of heat transfer. It does not tell anything about the conditions, under which heat can be transformed into work and also it does not indicate as to why the whole of heat energy cannot be converted into mechanical work continuously.

8.16 Isothermal Process

In this process, P and V change but $T = \text{constant}$ *i.e.*, change in temperature $\Delta T = 0$.

(1) Condition for isothermal process :

- The walls of the container must be perfectly conducting.
- The speed of process should be very slow.

(2) **Equation of state** : In all isothermal process Boyle's law is obeyed. Hence equation of state is $PV = \text{constant}$.

(3) Example of isothermal process :

- Melting process [Ice melts at constant temperature 0°C]
- Boiling process [water boils at constant temperature 100°C]

(4) Indicator diagram

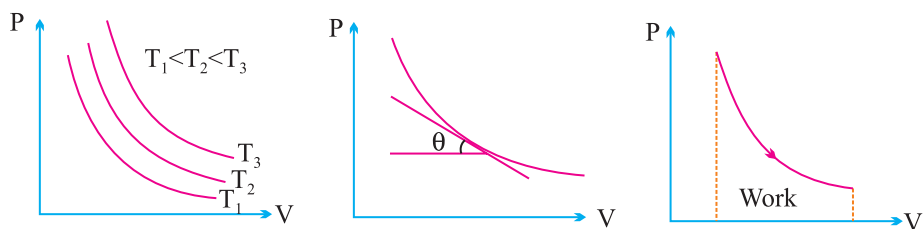

$$(5) \quad \text{Work done } W = \mu RT \log_e \left(\frac{V_f}{V_i} \right) = 2.303 \mu RT \log_{10} \left(\frac{V_f}{V_i} \right)$$

$$W = \mu RT \log_e \left(\frac{P_i}{P_f} \right) = 2.303 \mu RT \log_{10} \left(\frac{P_i}{P_f} \right)$$

(6) **Heat supplied in isothermal process :** $\Delta Q = \Delta W$ *i.e.*, heat supplied is used to do work against external surrounding.

8.17 Adiabatic Process

In this process P, V and T changes but $\Delta Q = 0$.

(1) **Essential conditions for adiabatic process :**

- (i) All walls of the container and the piston must be perfectly insulating.
- (ii) The speed of process should be fast.

(2) **Example of some adiabatic process :**

- (i) Sudden bursting of the tube of bicycle tyre.
- (ii) Propagation of sound waves in air and other gases.

(3) **Energy in adiabatic process :** For adiabatic process

$$\Delta Q = 0, \therefore \Delta U + \Delta W = 0$$

If $\Delta W =$ positive then $\Delta U =$ negative *i.e.*, adiabatic expansion produce cooling.

If $\Delta W =$ negative then $\Delta U =$ positive *i.e.*, adiabatic compression produce heating.

(4) **Equation of state :**

$$PV^\gamma = \text{constant}$$

It can also be re-written as

$$TV^{\gamma-1} = \text{constant}$$

and
$$\frac{T^\gamma}{P^{\gamma-1}} = \text{constant}$$

(5) **Indicator diagram :**

- (i) Curve obtained on PV graph are called adiabatic curve.

(ii) Slope of adiabatic curve

$$\tan \phi = -\gamma \left(\frac{P}{V} \right)$$

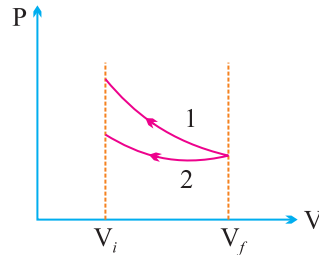

(6) Work done :

$$W = \frac{[P_i V_i - P_f V_f]}{(\gamma - 1)} = \frac{\mu R (T_i - T_f)}{(\gamma - 1)}$$

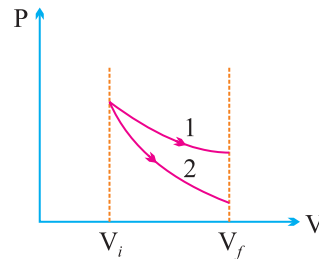

(7) **Free expansion :** Free expansion is adiabatic process in which no work is performed on or by the system. The final and initial energies are equal in free expansion.

8.18 Reversible and Irreversible Process

(1) **Reversible process :** A reversible process is one which can be reversed in such a way that all changes occurring in the direct process are exactly repeated in the opposite order and inverse sense. The conditions for reversibility are :

- (i) There must be complete absence of dissipative forces. (Friction, viscosity etc.)
- (ii) The speed of process should be infinitely slowly.
- (iii) The temperature of the system must not differ appreciably from its surroundings.

Examples of reversible process are :

- (a) All slow isothermal and adiabatic changes are reversible.
- (b) Very slow evaporation or condensation.

(2) **Irreversible process** : Any process which is not reversible exactly is an irreversible process. Examples of irreversible processes are :

- (i) Sudden expansion or contraction
- (ii) Heat transfer between bodies

8.19 Cyclic and Non-cyclic Process

A cyclic process consists of a series of changes which return the system back to its initial state.

In non-cyclic process the series of changes involved do not return the system back to its initial state.

- (1) In cyclic process change in internal energy is zero and temperature of system remains constant.
- (2) Heat supplied is equal to the work done by the system.
- (3) For cyclic process P–V graph is a closed curve and area enclosed by the closed path represents the work done.

If the cycle is clockwise work done is positive and if the cycle is anticlockwise work done is negative.

8.20 Graphical Representation of Various Processes

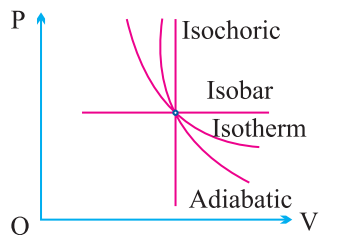

Heat engine is a device which converts heat into work continuously through a cyclic process.

The essential parts of a heat engine are :

Source : Working substance : Steam, petrol etc.

Sink : “efficiency” η is given by

$$\eta = \frac{\text{Work done}}{\text{Heat input}} = \frac{W}{Q_1}$$

also

$$\eta = \frac{Q_1 - Q_2}{Q_1} = 1 - \frac{Q_2}{Q_1}$$

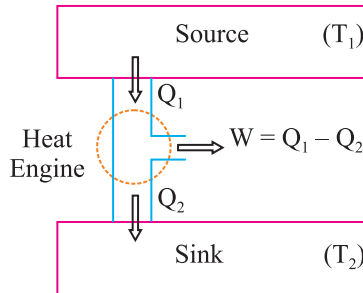

A perfect heat engine $\eta = 1$. Practically efficiency is always less than 1.

8.21 Refrigerator or Heat Pump.

A refrigerator or heat pump is basically a heat engine run in reverse direction.

It essentially consists of three same parts.

The performance of a refrigerator is expressed by means of “coefficient of performance” β which is defined as the ratio of the heat extracted from the cold body to the work needed to transfer it to the hot body.

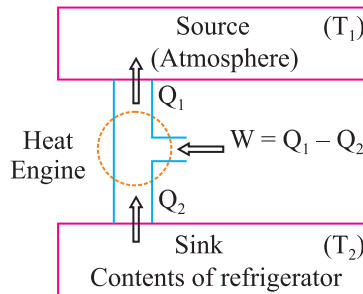

i.e.,

$$\beta = \frac{\text{Heat extracted}}{\text{work done}} = \frac{Q_2}{W} = \frac{Q_2}{Q_1 - Q_2}$$

A perfect refrigerator

$W = 0$ so that $Q_1 = Q_2$ and hence $\beta = \infty$.

(1) Carnot refrigerator :

$$\text{For carnot refrigerator} = \frac{Q_1}{Q_2} = \frac{T_1}{T_2}$$

$$\text{coefficient of performance } \beta = \frac{T_2}{T_1 - T_2}$$

where T_1 = temperature of surrounding, T_2 = temperature of cold body

- (2) Relation between coefficient of performance and efficiency of refrigerator

$$\beta = \frac{1-\eta}{\eta}$$

8.22 Second Law of Thermodynamics

- (1) **Clausius statement** : It is impossible for a self acting machine to transfer heat from a colder body to a hotter one without the aid of an external agency.
- (2) **Kelvin's statement** : It is impossible for a body or system to perform continuous work by cooling it to a temperature lower than the temperature of the coldest one of its surroundings.
- (3) **Kelvin-Planck's statement** : It is impossible to design an engine that extracts heat and fully utilises into work without producing any other effect.

8.23 Carnot Engine

Carnot designed a theoretical engine. This engine cannot be realised in actual practice.

- (1) **Carnot cycle** : The working substance of the engine undergoes a cycle known as Carnot cycle. It consists of the following four strokes.
- (i) Isothermal expansion :

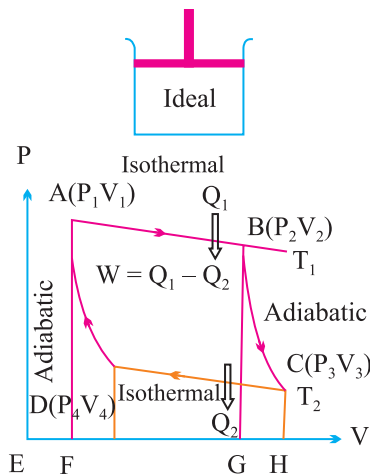

- (ii) Adiabatic expansion :
- (iii) Isothermal compression :
- (iv) Adiabatic compression :

(2) Efficiency of Carnot cycle :

$$\eta = \frac{\text{Work done}}{\text{Heat input}} = \frac{W}{Q_1}; \eta = 1 - \frac{T_2}{T_1}, T_1 \text{ and } T_2 \text{ are in Kelvin.}$$

- (i) Efficiency of a heat engine depends only on temperatures.
- (ii) Efficiency of a heat engine is always lesser than unity, *i.e.*, whole of heat can never be converted into work which is in accordance with second law.

(3) **Carnot theorem** : Carnot's reversible engine working between two given temperature is considered to be the most efficient engine.

TRANSMISSION OF HEAT

8.24 Introduction

The transfer of heat from one body to another may take place by one of the following modes.

Conduction	Convection	Radiation
Heat flows from hot end to cold end. Particles of the medium simply oscillate but do not leave their place.	Each particle absorbing heat is mobile.	Heat flows without any intervening medium in the form of electromagnetic waves.
Medium is necessary for conduction.	Medium is necessary for convection.	Medium is not necessary for radiation.
It is a slow process.	It is also a slow process.	It is a very fast process.
Path of heat flow may be zig-zag.	Path may be zig-zag or curved.	Path is a straight line.
Conduction takes place in solids.	Convection takes place in fluids.	Radiation takes place in gaseous and transparent media.
The temperature of the medium increases through which heat flows.	In this process also the temperature of medium increases.	There is no change in the temperature of the medium.

8.25 Conduction

(1) **Variable and steady state** : If temperature of every cross-section of the rod goes on increasing, hence rod is said to exist in variable state.

The state of the rod in which no part of rod absorbs heat is called steady state. (Temperature of every cross-section of the rod remains constant)

(2) **Isothermal surface** : Any surface having its all points at the same temperature, is called isothermal surface.

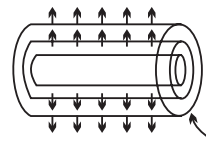
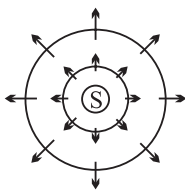
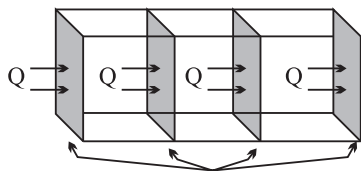

Plane Isothermal surfaces

Spherical Isothermal surfaces

Cylindrical Isothermal surfaces

(3) **Temperature Gradient** : The rate of change of temperature with distance between two isothermal surface is called temperature gradient.

$$\text{Temperature gradient} = \frac{(\theta - \Delta\theta) - \theta}{\Delta x} = \frac{-\Delta\theta}{\Delta t}$$

The negative sign show that temperature θ decreases as the distance x increases in the direction of heat flow.

(4) **Coefficient of thermal conductivity** : If L be the length of the rod, A the area of cross-section and θ_1 and θ_2 are the temperature of its two faces, then the amount of heat flowing from one face to the other face in time

$$t \text{ is given by } Q = \frac{KA (\theta_1 - \theta_2)t}{L}.$$

Where K is coefficient of thermal conductivity of material of rod.

(i) Units = $\text{Js}^{-1}\text{m}^{-1}\text{k}^{-1}$ or $\text{Wm}^{-1}\text{k}^{-1}$ (S.I.) CGS unit = $\text{cal s}^{-1} \text{cm}^{-1} \text{°C}^{-1}$

(ii) Dimension : $[\text{MLT}^{-3} \text{K}^{-1}]$

(iii) The magnitude of K depends only on nature of the material.

(iv) For perfect conductors, $K = \infty$ and for perfect insulators, $K = 0$

(v) The thermal conductivity of pure metals decreases with rise in temperature but for alloys thermal conductivity increases with increase of temperature.

(vi) Human body is a bad conductor of heat.

8.26 Combination of Conductors

(1) **Series combination** : Let n slabs each of cross-sectional area A are connected in the series Heat current is the same in all the conductors.

$$\text{i.e., } \frac{Q}{t} = H_1 = H_2 = H_3 \dots\dots\dots = H_n$$

(i) Equivalent resistance $R = R_1 + R_2 + R_3 + \dots\dots\dots R_n$

(ii) If K_s is equivalent conductivity,

$$\therefore \text{then } K_s = \frac{l_1 + l_2 + l_3 + \dots + l_n}{\frac{l_1}{K_1} + \frac{l_2}{K_2} + \frac{l_3}{K_3} + \dots + \frac{l_n}{K_n}}$$

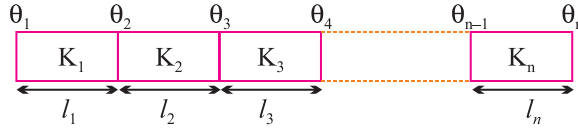

(2) **Parallel Combination :** Let n slabs each of length/are connected in parallel then.

(i) Equivalent resistance $\frac{1}{R} = \frac{1}{R_1} + \frac{1}{R_2} + \frac{1}{R_3} + \dots + \frac{1}{R_n}$

(ii) Temperature gradient across each slab will be same.

(iii) Heat current in each slab will be different.

$$\therefore K = \frac{K_1 A_1 + K_2 A_2 + K_3 A_3 + \dots + K_n A_n}{A_1 + A_2 + A_3 + \dots + A_n}$$

8.27 Convection

Mode of transfer of heat by means of migration of material particles of medium is called convection. It is of two types.

(1) **Natural convection :** This arise due to difference of densities at two places on account of gravity.

(2) **Forced convection :** If a fluid is forced to move then it is called forced convection. In this case Newton's law of cooling holds good. According to which rate of loss of heat from a hot body is directly proportional to the surface area of body and excess temperature of body over its surroundings.

$$i.e., \frac{Q}{t} \propto A(T - T_0)$$

where T = Temperature of body and T_0 = Temperature of surrounding

(i) Natural convection takes place from bottom to top while forced convection in any direction.

(ii) Natural convection is not possible in a gravity free region such as a free falling lift or an orbiting satellite.

8.28 Radiation

The process of the transfer of heat from one place to another place without heating the intervening medium is called radiation.

Properties of thermal radiation

- (1) Thermal radiations are also called infra-red radiations.
- (2) Medium is not required for the propagation of radiations.
- (3) Every body whose temperature is above zero Kelvin emits thermal radiation.
- (4) Their speed is equal to that of light.
- (5) They follow laws of reflection refraction, interference diffraction and polarisation.

QUESTIONS

1. Why spark is produced when two substances are struck hard against each other?
2. What is the specific heat of a gas in an isothermal process?
3. On what factors, does the efficiency of Carnot engine depend?
4. What are two essential features of Carnot's ideal heat engine?
5. Plot a graph between internal energy U and Temperature (T) of an ideal gas.
6. Refrigerator transfers heat from cold body to a hot body. Does this violate the second law of thermodynamics?
7. Is it possible to increase the temperature of gas without giving it heat?
8. Can the specific heat of a gas be infinity?
9. Out of the parameters : temperature, pressure, work and volume, which parameter does not characterise the thermodynamics state of matter?
10. Why a gas is cooled when expanded?
11. Why does air pressure in car tyre increases during driving?
12. Heat is supplied to a system, but its internal energy does not increase. What is the process involved?
13. Under what ideal condition the efficiency of a Carnot engine be 100%.

14. Which thermodynamic variable is defined by the first law of thermodynamics ?
15. Is coefficient of performance of a refrigerator a constant quantity ?
16. What is the efficiency of carnot engine working between ice point and steam point ?
17. Heat cannot flow itself from a body at lower temperature to a body at higher temperature is a statement or consequence of which law of thermodynamics ?
18. What is the specific heat of a gas in an adiabatic process ?

SHORT ANSWER TYPE QUESTIONS (2 MARKS)

19. Heat system based on circulation of steam are more efficient in warning a building than those based on circulation of hot water why ?
20. Write two limitation of the first law of thermodynamics.
21. Write the expressions for C_v and C_p of a gas in terms of gas constant R and γ where

$$\gamma = C_p / C_v$$

22. No real engine can have an efficiency greater that of a carnot engine working between the same low temperatures. Why ?
23. Why water at the base of a waterfall is slightly warmer than at the top ?
24. When ice melts, the change in internal energy is greater than the heat supplied. Why ?
25. Give two statements for the second law of thermodynamics.
26. An ideal monatomic gas is taken round the cycle ABCDA as shown. Calculate the work done during the cycle.

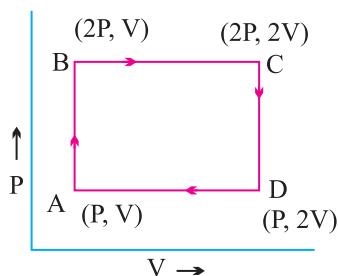

27. Can a room be cooled by opening the door of refrigerator in a closed room ?
28. Explain what is meant by isothermal and adiabatic operations.
29. Two bodies at different temperatures T_1 and T_2 , if brought in thermal contact do not necessarily settle to the mean temperature $(T_1 + T_2)/2$ Explain.

SHORT ANSWER TYPE QUESTIONS (3 MARKS)

30. Obtain an expression for work done in an isothermal process.
31. Identify and name the Thermodynamic processes 1, 2, 3 as shown in figure.

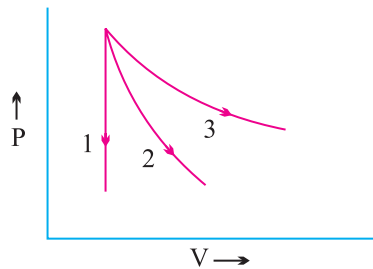

32. Two samples of gas initially at the same temperature and pressure are compressed from volume V to $V/2$ one sample is compressed isothermally and the other adiabatically in which case the pressure will be higher ? Explain ?
33. Explain briefly the principle of a heat pump. What is meant by coefficient of performance ?
34. (a) Why a gas has two principal specific heat capacities ?
(b) Which one is greater and why ?
(c) Of what significance is the difference between these two specific heat capacities and their ratio ?
35. Is it a violation of the second law of thermodynamics to convert
(a) Work completely into heat
(b) Heat completely into work
Why or why not ?
36. State first law of thermodynamics. On its basis establish the relation between two molar specific heat for a gas.

37. Explain briefly the working principle of a refrigerator and obtain an expression for its coefficient of performance.
38. State zeroth law of thermodynamics. How does it lead to the concept of temperature ?
39. What is a cyclic process ? Show that the net work done during a cycle process is numerically equal to the area of the loop representing the cycle.
40. A gas has two specific heats *i.e.*, C_p and C_v which one is greater and why ?
41. What is an isothermal process ? Derive an expression for work done during an isothermal process.

LONG ANSWER TYPE QUESTIONS (5 MARKS)

42. Describe briefly carnot engine and obtain an expression for its efficiency.
43. Define adiabatic process. Derive an expression for work done during adiabatic process.
44. Why a gas has two principle specific heat capacities ? What is the significance of $C_p - C_v$ and C_p/C_v where symbols have usual meaning.

NUMERICALS

45. When a system is taken from state A to state B along the path ACB, 80 k cal of heat flows into the system and 30 k cal of work is done.
 - (a) How much heat flows into the system along path ADB if the work done is 10 k cal ?
 - (b) When the system is returned from B to A along the curved path the work done is 20 k cal. Does the system absorb or liberate heat.
 - (c) If $U_A = 0$ and $U_D = 40$ k cal, find the heat absorbed in the process AD

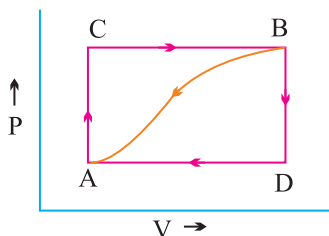

46. $\frac{1}{2}$ mole of helium is contained in a container at S.T.P. How much heat energy is needed to double the pressure of the gas, keeping the volume constant ? Heat capacity of gas is $3 \text{ J g}^{-1} \text{ K}^{-1}$.

47. A thermodynamic system is taken from an original state to an intermediate state by the linear process shown in Fig.

Its volume is then reduced to the original value from E to F by an isobaric process. Calculate the total work done by the gas from D to E to F.

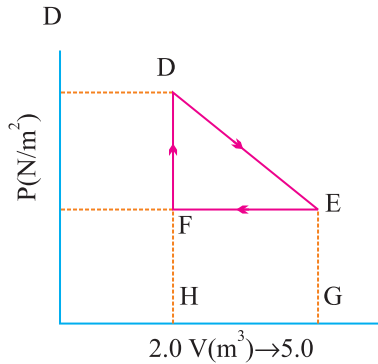

48. What is the coefficient of performance (β) of a carnot refrigerator working between 30°C and 0°C ?
49. Calculate the fall in temperature when a gas initially at 72°C is expanded suddenly to eight times its original volume. ($\gamma = 5/3$)
50. Refrigerator is to maintain eatables kept inside at 9°C . If room temperature is 36°C calculate the coefficient of performance.
51. A perfect carnot engine utilizes an ideal gas the source temperature is 500 K and sink temperature is 375 K. If the engine takes 600 k cal per cycle from the source, calculate
- The efficiency of engine
 - Work done per cycle
 - Heat rejected to sink per cycle
52. Two carnot engines A and B are operated in series. The first one A receives heat at 900 K and reject to a reservoir at temperature T K.
- The second engine B receives the heat rejected by the first engine and in turn rejects to a heat reservoir at 400 K calculate the temperature T when
- The efficiencies of the two engines are equal
 - The work output of the two engines are equal

57. Consider two containers A and B containing identical gases at the same pressure, volume and temperature. The gas in container A is compressed to half of its original volume isothermally while the gas in container B is compressed to half of its original value adiabatically. The ratio of final pressure of gas in B that of gas in A is

- (a) $2^{\gamma-1}$ (b) $\left(\frac{1}{2}\right)^{\gamma-1}$
 (c) $\left(\frac{1}{1-\gamma}\right)^2$ (d) $\left(\frac{1}{\gamma-1}\right)^2$

58. Which of the process described below are irreversible?

- (a) The increase in temperature of an iron rod by hammering it
 (b) A gas in a small container at a temperature T_1 is brought in contact with a big reservoir at a higher Temperature. T_2 which inverses the temperature of the gas
 (c) A quasi - state isothermal expansion of an ideal gas in cylinder fitted with a frictionless piston
 (d) An ideal gas is enclosed in a piston cylinder arrangement with adiabatic Walls. A weight W is added to the piston, resulting in compression of a gas

59. An ideal gas undergoes isothermal process from some initial state i to final state f. Choose the correct alternative

- (a) $dU = 0$ (b) $d\theta = 0$
 (c) $d\theta = dU$ (d) $dQ = dw$

60. Fig. shows the P-V diagram of an ideal gas undergoing a change of state from A to B. from different process I, II, III & IV as shown in figure may lead to the same change of state

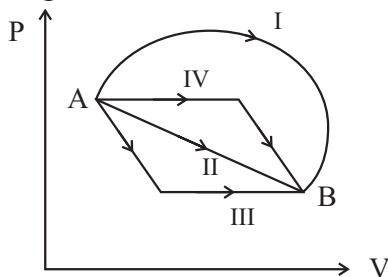

- (a) Change in internal energy is same in IV and III cases but not in I and II
- (b) Change in internal energy is same in all the four cases
- (c) Work done is maximum is Case I
- (d) Work done is minimum in case II
61. A mono-atomic gas at a pressure P , having a volume V expand isothermally to a volume $2V$ and then adiabatically to a volume $16V$. The final pressure of the gas is ($\gamma = 5/3$)
- (a) $64 P$ (b) $32 P$
- (c) $P/64$ (d) $16 P$
62. One mole of an ideal diatomic gas undergoes a transition from A to B along a path AB as shown in fig. The change in internal energy of the gas during the transition is ($\gamma = \frac{3}{5}$)

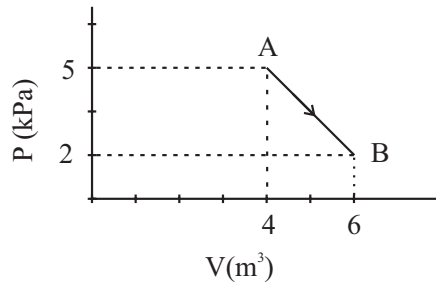

- (a) -20 KJ (b) 20 J
- (c) -12 KJ (d) 20 KJ
63. At 27°C two moles of an ideal mono-atomic gas occupy a volume V . The gas expands adiabatically to a volume $2V$. The final temperature of the gas is $\left[\text{Take } \gamma = \frac{5}{3} \right]$
- (a) 179 K (b) 189 K
- (c) 213 K (d) 219 K

64. In the above question, change in internal energy of the gas is

- (a) -2660.23 J (b) -2777.23 J
(c) -2767.23 J (d) -2600 J

65. P-V plots for two gases during adiabatic process are shown in fig. Plots 1 & 2 should correspond respectively to

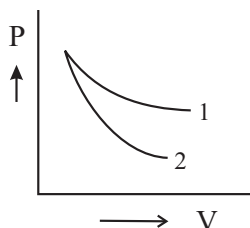

- (a) He and O_2 (b) O_2 and He
(c) He and Ar (d) O_2 and N_2

66. The work of 146 KJ is performed in order to compress one kilomole of a gas adiabatically, and in this process, the temperature of the gas increase by 7°C . The gas is

- (a) Triatomic (b) Monoatomic
(c) Diatomic
(d) Mixture of monoatomic and diatomic

67. In V-T diagram shown in fig., what is the relation between P_1 and P_2 ?

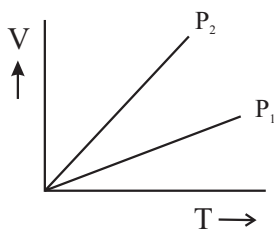

- (a) P_2 and P_1 (b) $P_2 > P_1$
(c) $P_2 < P_1$ (d) Cannot say

72. A Carnot engine, having an efficiency of $\eta = \frac{1}{10}$ as heat engine is used as a refrigerator. If the work done on the system is 10J the amount of energy absorbed from the reservoir at lower temperature is
- (a) 99 J (b) 90 J
(c) 1 J (d) 100 J
73. The door of a running refrigerator inside a room is left open. The correct statement out of the following ones is
- (a) The room will be cooled slightly
(b) The room will be warmed up gradually
(c) The room will be cooled to the temperature inside the refrigerator
(d) The temperature of the room will remain unaffected.
74. If Metal is heated to temperature θ and then allowed to cool in a room which is at temperature θ_0 , the graph between the temperature T of the metal and time t will be closest to :

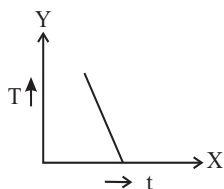

(a)

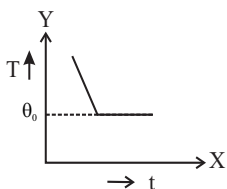

(b)

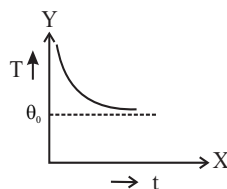

(c)

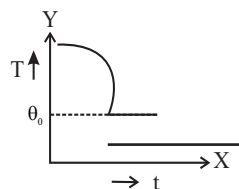

(d)

ASSERTION - REASON BASED QUESTIONS

Direction:- In the following questions, a statement of assertion is followed by a statement of reason. Mark the correct choice as :

- (a) If both assertion and reason are true and reason is the correct explanation of assertion.
(b) If both assertion and reason are true but reason is not correct explanation of assertion.
(c) If assertion is true, but reason is false.
(d) If both assertion and reason are false.
1. Assertion : The specific heat of a gas in an adiabatic process is zero and in an isothermal process is infinite.

Reason : Specific heat of gas is directly proportional to change of heat in system and inversely proportional to change in temperature.

2. Assertion : We cannot change the temperature of a body without giving (or taking) heat to (or from) it.

Reason : According to principle of conservation of energy the total energy of the system should remain conserved.

3. Assertion : In isothermal process whole of the heat energy is converted in to internal energy.

Reason : According to first law of thermal dynamics, $\Delta Q = \Delta U - P\Delta V$

4. Assertion : When a bottle of cold carbonated drink is opened, a slight fog forms around the opening.

Reason : Adiabatic expansion of gas causes lowering of temperature and condensation of water vapours.

5. Assertion : The isothermal curves intersect each other at a certain point.

Reason : The isothermal changes takes place slowly, so the isothermal curves have large slope.

6. Assertion : Work and heat are two equivalent form of energy.

Reason : Work is the transfer of mechanical energy irrespective of the temperature difference, whereas heat is the transfer of thermal energy because of temperature difference only.

7. Assertion : The heat supplied to a system is always equal to increases in its internal energy.

Reason : When a system changes from one thermal equilibrium to another, some heat is absorbed by it.

8. Assertion : A room can be cooled by opening the door of a refrigerator in closed room.

Reason : Heat flows from lower temperature (refrigerator) to higher temperature (room).

9. Assertion : It is not possible for a system, unaided by an external agency to transfer heat from a body at lower temperature to another body at higher temperature.

Reason : According to Clausius statement, no process is possible whose sole result is the transfer of heat for a cooled object to a hotter object.

- 10.** Assertion : If an electric fan be switched on in closed room, the air of the room will be cooled.
Reason : Fan air decreases the temperature of the room.
- 11.** Assertion : The internal energy of an isothermal process does not change.
Reason : The internal energy of a system depends only on the pressure of the system.
- 12.** Assertion : In an adiabatic compression, the internal energy and temperature of the system got decreases.
Reason : The adiabatic compression is a slow process.
- 13.** Assertion : Thermodynamic process in nature are irreversible.
Reason : Dissipative effects cannot be eliminated.
- 14.** Assertion : Air quickly leaking out of balloon becomes coolers.
Reason : The leaking air undergoes adiabatic expansion.
- 15.** Assertion : Work done by a gas in isothermal expansion is more than the work done by the gas in the same expansion.
Reason : Temperature remains constant in isothermal expansion and not in adiabatic expansion.
- 16.** Assertion : An adiabatic process is an isoentropic process.
Reason : Change in entropy is zero in case of adiabatic process.
- 17.** Assertion : First law of thermodynamics is a restatement of law of conservation of energy.
Reason : Energy is a fundamental quantity.
- 18.** Assertion : Zeroth law of thermodynamics explain the concept of energy.
Reason : Energy is independent of temperature.
- 19.** Assertion : Efficiency of Carnot engine increases on reducing the temperature of sink.
Reason : The efficiency of Carnot engine is defined as ratio of net mechanical work done per cycle by the gas to the amount of heat energy absorbed per cycle from the source.
- 20.** Assertion : The entropy of solids is the highest.
Reason : Atoms of the solids are arranged in orderly manner.

If in one cycle of its operation the system draws Q_1 heat from the hot reservoir, does W work and releases Q_2 heat to the cold reservoir than.

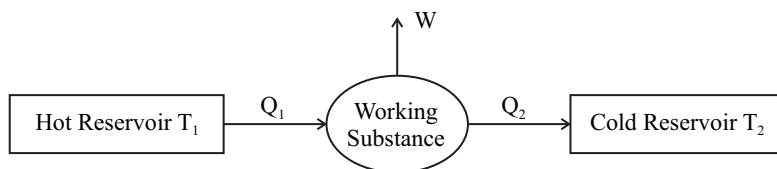

Efficiency of engine,
$$\eta_1 = \frac{W}{Q_1} = \frac{Q_1 - Q_2}{Q_1} = 1 - \frac{Q_2}{Q_1}$$

Answer the following questions (do any four)

- (i) The area enclosed by a Carnot cycle represents.
 - (a) heat absorbed
 - (b) heat released
 - (c) amount of work done
 - (d) none of these
- (ii) A reversible heat engine 'A' operates between 223°C and 123°C . The efficiency of engine is
 - (a) 15%
 - (b) 20%
 - (c) 25%
 - (d) 30%
- (iii) Another reversible engine 'B' operates between temperature 123° and $T^\circ\text{C}$ and has the efficiency 30%. The value of 'T' will be
 - (a) 7°C
 - (b) 10°C
 - (c) 280°C
 - (d) 320°C
- (iv) Even Carnot engine cannot give 100% efficiency, because we cannot
 - (a) prevent radiation
 - (b) find ideal source
 - (c) eliminate friction
 - (d) reach absolute zero temperature
- (v) The efficiency of heat engine
 - (a) more in plane area than hilly areas
 - (b) less in plane area than hilly areas
 - (c) remains same in both areas
 - (d) depends upon nature of working substance
- (vi) The efficiency of Carnot engine does not depend on
 - (a) temperature of source
 - (b) temperature of sink
 - (c) nature of working substance
 - (d) temperature difference of source and sink temperature

(v) Consider a compound slab consisting of two different materials having equal thickness and thermal conductivities K and $2K$ respectively. The equivalent thermal conductivity of the slab is

- (a) $\frac{4K}{3}$ (b) $\frac{2K}{3}$ (c) $\sqrt{2}K$ (d) $3K$

ANSWERS

VERY SHORT ANSWERS (1 MARK)

1. Work is converted into heat.
2. Infinite.
3. $\eta = 1 - T_2/T_1$. On the temperature of sink and source.
4. (i) Source and sink have infinite heat capacities.
(ii) Each process of the engine's cycle is fully reversible.

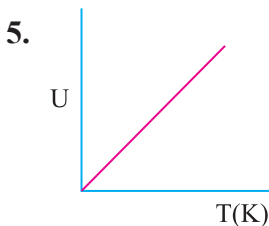

6. No, External work is done.
7. Yes, it happens during an adiabatic process.
8. Yes.
9. Work.
10. Decrease in internal energy.
11. $PV = nRT$
 $V = \text{constant}$, $T = \text{increases}$. So, P also increases $P \propto T$
12. Isothermal expansion.
13. If the temperature of sink is zero kelvin.
14. Internal energy.
15. No. As the inside temperature of the refrigerator decreases, its coefficient of performance decreases.

16. $\eta = 1 - T_2/T_1 = 1 - 273/373 = 26.8\%$

17. Second law of thermodynamics.

18. Zero.

SHORT ANSWERS (2 MARKS)

19. Because steam at 100°C has more heat than water at 100°C.

20. (i) It does not give the direction of flow of heat.

(ii) It does not explain why heat cannot be spontaneously converted into work.

21.

$$\gamma = C_p/C_v$$

$$C_p - C_v = R$$

$$C_p = \gamma C_v$$

$$(\gamma - 1)C_v = R; C_v = \frac{R}{\gamma - 1}$$

$$C_p = \frac{\gamma R}{\gamma - 1}$$

22. In carnot engine.

(i) There is absolutely no friction between the wall of cylinder and piston.

(ii) Working substance is an ideal gas

In real engine these condition cannot be fulfilled.

23. Potential energy converted into kinetic energy, some part of kinetic energy is converted into heat.

24. $dq = du + dw$

$$du = dq - pdv.$$

26. PV

27. No, It is a violates seconds law.

28. Adiabatic a Process : Pressure, volume and temperature of the system changes but there is no exchange of heat.

Isothermal Process : Pressure, volume changes temperature remain constant.

29. Heat flows from higher temperature to lower temperature until the temperature become equal.

Two bodies

$$m_1 = \text{mass of 'A'} \quad \boxed{T_1} \quad \boxed{T_2} \quad m_2 = \text{mass of 'B'}$$

$$c_1 = \text{specific heat of A} \quad c_2 = \text{specific heat of B}$$

Let $T_1 > T_2$ Heat will be lost by 'A' and gained by 'B' According to principle of calorimetry,

$$\text{Heat lost} = \text{Heat gained}$$

Let their common temperature attained be 'T',

$$m_1 c_1 (T_1 - T) = m_2 c_2 (T - T_2)$$

$$m_1 c_1 T_1 - m_1 c_1 T = m_2 c_2 T - m_2 c_2 T_2$$

$$m_1 c_1 T_1 + m_2 c_2 T_2 = (m_1 c_1 + m_2 c_2) T$$

$$T = \frac{m_1 c_1 T_1 + m_2 c_2 T_2}{(m_1 c_1 + m_2 c_2)}$$

It is possible only,

$$\text{If } m_1 = m_2 = m, C_1 = C_2 = C,$$

$$T = \frac{T_1 + T_2}{2}.$$

45. (a) $dw_{\text{ADB}} = + 10 \text{ k cal}$

Internal energy is path independent

$$du_{\text{ADB}} = du_{\text{ACB}} = 50 \text{ k cal}$$

$$dQ_{\text{ADB}} = 50 + 10 = 60 \text{ k cal}$$

(b) $dw_{\text{BA}} = - 20 \text{ k cal}$

$$du_{\text{BA}} = - du_{\text{ADB}}$$

$$dQ_{\text{BA}} = du_{\text{BA}} + dw_{\text{BA}}$$

$$= - 50 - 20 = - 70 \text{ k cal}$$

(c) $U_{\text{A}} = 0, U_{\text{D}} = 40 \text{ k cal}$

$$du_{\text{AD}} = 40 \text{ k cal}$$

$$dw_{\text{ADB}} = 10 \text{ k cal}$$

$$dw_{\text{DB}} = 0 \text{ since } dV = 0$$

$$dQ_{\text{AD}} = 40 + 10 = 50 \text{ k cal}$$

46. $n = \frac{1}{2}$, $C_v = 3 \text{ J/gK}$. $M = 4$

$$C_v = MC_v = 12 \text{ J/mole } k, M \rightarrow \text{Molecular mass}$$

$$\frac{P_2}{P_1} = \frac{T_2}{T_1} = 2$$

$$\Delta T = 2T_1 - T_1 = 273 \text{ K}$$

$$\Delta Q = nC_v \Delta T = 1638 \text{ J}$$

47. Total work done by the gas from D to E to F.

$$W = W_{DE} + W_{EF}$$

$$= \text{Area of trapezium DEGHD} - \text{Area of rectangle EFHG}$$

$$= \text{Area of triangle DEF}$$

$$= \frac{1}{2} DE \times FE$$

$$= \frac{1}{2} (600 - 300) \text{ Nm}^{-2} \times (5.0 - 2.0) \text{ m}^3$$

$$= 450 \text{ J.}$$

48. $\beta = \frac{T_2}{T_1 - T_2} = \frac{273}{303 - 273} = 9.1$

49.

$$T_1 V_1^{\gamma-1} = T_2 V_2^{\gamma-1}$$

$$T_2 = T_1 \left(\frac{V_1}{V_2} \right)^{\gamma-1}$$

$$= 345 \times \frac{1}{4} = 86.25 \text{ K}$$

50. Here $T_1 = 273 + 36 = 309 \text{ K}$,

$$T_2 = 273 + 9 = 282 \text{ K.}$$

Coefficient of performance.

$$\beta = \frac{T_2}{T_1 - T_2} = \frac{282}{309 - 282} = \frac{282}{27} = 10.4$$

51. $T_1 = 500 \text{ K}$, $T_2 = 375 \text{ K}$

$Q_1 = \text{Heat absorbed} = 600 \text{ k cal}$

$$\eta = 1 - T_2/T_1 = \frac{125}{500} = 0.25$$

$$= 25\%$$

(b) $\eta = \frac{W}{Q_1}$

$$W = \eta Q_1 = 0.25 \times 600 \text{ k cal}$$

$$= 150 \text{ k cal}$$

(c) $w = Q_1 - Q_2$ $Q_2 = Q_1 - W = 600 - 150$

$$= 450 \text{ k cal}$$

52.

$$W_A = W_B$$

$$\frac{W}{Q_1} = \left(1 - \frac{T_2}{T_1}\right)$$

$$W = Q_1 \left(1 - T_2/T_1\right)$$

$$Q_2 \left(1 - \frac{T_3}{T_2}\right) = Q_1 \left(1 - \frac{T_2}{T_1}\right)$$

$$\left(1 - \frac{T}{900}\right) Q_1 = \left(1 - \frac{400}{T}\right) Q_2$$

$$\left(1 - \frac{T}{900}\right) Q_1 = \left(1 - \frac{400}{T}\right) \frac{T}{900}$$

$$1 - \frac{T}{900} = \frac{T}{900} - \frac{400}{900}$$

$$\frac{2T}{900} = \frac{13}{9}$$

$$T = 650 \text{ K}$$

$$\eta_A = \eta_B$$

$$1 - \frac{T}{900} = \frac{1 - 400}{T}$$

$$T^2 = 900 \times 400$$

$$= 600 \text{ k}$$

$$T_1 = 273 \text{ k}, T_2 = 673 \text{ k}$$

mass of gas = 10 mole

$$W_{\text{adia}} = \frac{10R}{(\gamma-1)}(T_1 - T_2)$$

$$= \frac{10 \times 8.4}{(1.4-1)}(273 - 673)$$

$$= -8.4 \times 10^4 \text{ J work being done on the gas}$$

$$du = -dw = 8.4 \times 10^4 \text{ J}$$

54. $\eta = 1 - \frac{T_2}{T_1}$

(i) T_1 is increased from 1500°C to 1600°C

$$T_1 = 1873 \text{ k}$$

T_2 Remain constant $T_2 = 773 \text{ k}$

$$\eta_1 = \frac{1873 - 773}{1873} = 58.73\%$$

(ii) T_1 remain constant = 1500°C

$$T_1 = 1500 + 273 = 1773 \text{ k}$$

T_2 is decreased by 100 *i.e.*, 400°C

$$T_2 = 400 + 273 = 673 \text{ k}$$

$$\eta_2 = \frac{1773 - 673}{1773} = \frac{1100}{1773} = 62.04\%$$

$$\eta_2 > \eta_1.$$

SOLUTION (MCQ)

55. (c) In curve 1, V is constant : It represents isochoric process. In curve 4, P is constant. It represents isobaric process. Out of curves 2 & 3, one is isothermal and other is adiabatic process. As slope of curve 2

is more than the slope of 3, therefore. Curve 2 represents adiabatic process.

56. (b) Work done by the gas is equal to area of rectangle ABCDA fig.
 $= AB \times BC$

$$= (2V_0)P_0 = 2 P_0V_0$$

As the trace is anticlockwise, the work is done on the gas. Work done by the gas $= -2P_0V_0$

57. (a) When the compression is isothermal for gas in A $P_2 V_2 = P_1 V_1$

$$P_2 = \frac{P_1 V_1}{V_2} = P_1 = \frac{V_1}{V_1/2} = 2 P_1$$

For gas in B, when compression is adiabatic

$$P_2 V_2^\gamma = P_1 V_1^\gamma$$

$$P_2 = P_1 \left(\frac{V_1}{V_2} \right)^\gamma = P_1 \left(\frac{V_1}{V_1/2} \right)^\gamma = 2^\gamma P_1$$

$$\text{So } \frac{P_2}{P_1} = \frac{2^\gamma P_1}{2 P_1} = 2^{\gamma-1}$$

58. (a, b, d)

59. (a,d) In isothermal process $dU = 0$

From $d\theta = dU + dW$ when $dU = 0 \rightarrow d\theta = dW$

60. (b,c) From the given initial state A to final state B change in internal energy is same in all the four Cases as it is independent of the path from A to B.

As work done = area under P-V curve therefore, work done is maximum in Case I.

61. (c) If P_2 is pressure after isothermal expansion, then

$$P_2 V_2 = P_1 V_1 \quad ; \quad P_2 = P_1 \frac{V_1}{V_2} = P \times \frac{V}{2V} = \frac{P}{2}$$

If P_3 is pressure after adiabatic expansion, then

$$P_2 V_2^\gamma = P_3 V_3^\gamma$$

$$\begin{aligned} P_3 &= P_2 \left(\frac{V_2}{V_3} \right)^\gamma = \frac{P}{2} \left(\frac{2V}{16} \right)^{5/3} = \frac{P}{2} \left(\frac{1}{8} \right)^{5/3} \\ &= \frac{P}{2} \left(\frac{1}{2^3} \right)^{5/3} = \frac{P}{2} \times \frac{1}{2^5} = \frac{P}{64} \end{aligned}$$

62. (a) Change in internal energy

$$\Delta U = nC_v \Delta T \text{ and } T = \frac{PV}{nR}$$

$$\Delta T = T_2 - T_1 = \frac{P_2 V_2 - P_1 V_1}{nR}, \quad C_v = \frac{R}{\gamma - 1}$$

$$\begin{aligned} \Delta U &= \frac{nR}{\gamma - 1} \left(\frac{P_2 V_2 - P_1 V_1}{nR} \right) = \frac{P_2 V_2 - P_1 V_1}{\gamma - 1} \\ &= \frac{5 \times 4 - 2 \times 6}{\frac{5}{3} - 1} = \frac{20 - 12}{-2/5} = \frac{-8}{2/5} = -20 \text{ KJ} \end{aligned}$$

63. (b) In an adiabatic change $T_2 V_2^{\gamma-1} = T_1 V_1^{\gamma-1}$

$$\text{or } T_2 = T_1 \left(\frac{V_1}{V_2} \right)^{\gamma-1}$$

$$T_2 = 300 \left(\frac{V}{2V} \right)^{\frac{5}{3}-1} = 300 (0.5)^{2/3}$$

$$T_2 = 189.03 \text{ K.}$$

64. (c) Change in internal energy $\Delta U = nC_v \Delta T$, n = No of moles

$$C_v = \frac{R}{\gamma - 1} \therefore \Delta U = \frac{nR}{\gamma - 1} \Delta T$$

$$\Delta U = \frac{2 \times 8.31 \times (189 - 300)}{\frac{5}{3} - 1} = -2767.23 \text{ J}$$

65. (b) In an adiabatic process, slope of P-V graph $= \frac{dP}{dV} = -\gamma \frac{P}{V}$

i.e. slope $\propto \gamma$ (with -ve sign)

So $(\text{slope})_2 > (\text{slope})_1 \therefore \gamma_2 > \gamma_1$

\therefore plot 1 corresponds to O_2 ($\gamma = 1.4$) and Plot 2 corresponds to He ($\gamma = 1.67$). Choice (b) is correct.

66. (c) Here $W = -146 \text{ KJ} = -146 \times 10^3 \text{ J}$

$$T_2 - T_1 = 7^\circ\text{C}, R = 8.31 \text{ mole}^{-1} \text{ K}^{-1}$$

$$= 8.3 \times 10^3 \text{ J kilomole}^{-1} \text{ K}^{-1}$$

$$\text{As } w = \frac{R(T_2 - T_1)}{1 - \gamma}$$

$$-146 \times 10^3 = \frac{8.3 \times 10^3 \times 7}{1 - \gamma}$$

$$\gamma - 1 = \frac{8.3 \times 10^3 \times 7}{146 \times 10^3} = 0.40$$

$\gamma = 1.40$ The gas must be diatomic.

67. (c) In an isobaric process $P = \text{constant}$ and

$$V \propto T \text{ or } V = \left(\frac{nR}{P} \right)^T$$

V-T graph is a straight line with slope $\propto \frac{1}{P}$

$$(\text{slope})_2 > (\text{slope})_1 \therefore P_2 < P_1$$

68. (d) The incorrect statement is (d). This is because in going from B to C or D to A ; $dV = 0$

$$\therefore dW = p.dV = 0$$

69. (a) The equation of adiabatic change is

$$P_V^\gamma = \text{constant which gives}$$

$$P^{1-\gamma} T^\gamma = \text{constant}$$

$$P^{1-\gamma} \propto \frac{1}{T^\gamma} \text{ or } P \propto T \left(\frac{\gamma}{\gamma-1} \right)$$

$$\text{As } P \propto T^3 \therefore \frac{\gamma}{\gamma-1} = 3 \text{ or } \gamma = \frac{3}{2}$$

$$\text{Hence } \frac{C_p}{C_v} = \gamma = \frac{3}{2}$$

70. (d) As $Q = e \sigma T^4 At$
 So $e = \frac{Q}{\sigma T^4 At} = \frac{300}{(5-67 \times 10^{-8}) \times (1001)^4 \times (5 \times 10^4) \times 60}$
 $= 0.18$

71. (c) $\eta_1 = 1 - \frac{273+0}{200+273} = \frac{200}{473}$

$\eta_2 = 1 - \frac{-200+273}{0+273} = \frac{200}{273}$

Hence $\eta_2 / \eta_1 = 0.577$

72. (b) Here $\eta = \frac{1}{10}$, $W = 10 \text{ J}$, $\theta_2 = ?$

$\beta = \frac{1-\eta}{\eta} = \frac{1-\frac{1}{10}}{\frac{1}{10}} = 9$

As $\beta = \frac{\theta_2}{W}$ or $\theta_2 = 90 \text{ J}$

73. (b) C.O.P. $= \frac{Q_2}{W} = \frac{T_2}{T_1 - T_2}$

when door is left open $T_2 \rightarrow T_1$, Hence C.O.P. \uparrow i.e. $\theta_2 \uparrow$. So heat energy given to the room increases.

ASSERTION - REASON BASED ANSWERS

- | | | | | | |
|---------|---------|---------|---------|---------|---------|
| 1. (a) | 2. (d) | 3. (d) | 4. (a) | 5. (d) | 6. (a) |
| 7. (d) | 8. (d) | 9. (a) | 10. (d) | 11. (c) | 12. (d) |
| 13. (a) | 14. (a) | 15. (b) | 16. (a) | 17. (c) | 18. (d) |
| 19. (b) | 20. (a) | | | | |

SOLUTION

- (a) $C = \frac{Q}{m\Delta T}$. For adiabatic process $Q = 0$ and for isothermal process $\Delta T = 0$.
- (d) We can change the temperature by doing work on the body eg. in an adiabatic compression temperature rises and in adiabatic expansion temperature falls, although no heat is given as taken from the system.

3. (d) As there is no change in internal energy of the system during an isothermal change. According to FLOT $\Delta Q = \Delta U + P\Delta V$. Hence, both are false.
4. (a) When a bottle of cold carbonated drink is opened. A slight fog is formed around the opening. This is because of adiabatic expansion of gas causes lowering of temperature and condensation of water vapours.
5. (d) As isothermal process are very slow and so different isothermal curves have different slopes so they cannot intersect each other and adiabatic compression is a fast process.
6. (a) Heat is similar to work, in that ways of transferring energy. Neither heat nor work is an intrinsic property of a system, that is, we cannot say that.
7. (d) According to first law of thermodynamic,

$$\Delta Q = \Delta U + \Delta W = \Delta U + P\Delta V,$$
 if heat is supplied such that $\Delta V = 0$ i.e. isochoric process, than the whole heat energy supplied to the system will increase the internal energy only. Also heat may be absorbed or evolved when state of thermal equilibrium changes.
8. (d) When door of refrigerator is kept often, heat rejected by the refrigerator to the room will be more than the heat taken by the refrigerator from the room. Therefore, temperature of room will increase and so it will be warmed gradually. As according to 2nd law of thermodynamics, heat cannot be transferred on its own, from a body at lower temperature to another at higher temperature.
9. (a) both assertion and reasoning statement are true.
10. (d) If an electric fan is switched on in a closed room, the air will be heated because due to the motion of the fan the speed of air molecules will increase. In fact, we feel cold due to evaporation of our sweat.
11. (c) Internal energy of system depends only on it's temperature. In isothermal process temperature does not change, therefore, the internal energy of the system remains the same.
12. (d) Adiabatic compression is rapid action and both the internal energy and the temperature increases.
13. (a) In thermodynamic process, there always occurs some loss of energy which is not recovered back.

14. (a) Adiabatic expansion produces cooling.

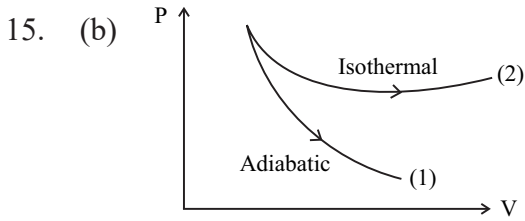

As from the curve, area covered under P–V curve is equal to work done.

Area under curve(2) > Area under curve(1)

16. (a) Change in entropy, $\Delta S = \frac{\Delta Q}{T}$. In adiabatic change, $\Delta Q = 0$.

So, $\Delta S = 0$. $S = \text{constant}$ i.e. entropy remains constant in an adiabatic process.

18. (d) Zeroth law of thermodynamics explains the concept of temperature. According to which there exists a scalar quantity called temperature which is the property of all thermodynamics system.

19. (b) Efficiency, $\eta = \frac{W}{Q_1} = 1 - \frac{T_2}{T_1}$ for Carnot engine. When T_2 decreases, η increases.

20. (a) Entropy is a measures of the disorder or randomness of the system. Greater the randomness, greater the entropy.

CASE STUDY BASED ANSWERS

- | | | | | | |
|----|--------|---------|----------|---------|--------|
| 1. | i. (b) | ii. (a) | iii. (b) | iv. (c) | v. (c) |
| 2. | i. (c) | ii. (b) | iii. (a) | iv. (d) | v. (b) |
| 3. | i. (a) | ii. (b) | iii. (d) | iv. (c) | v. (a) |

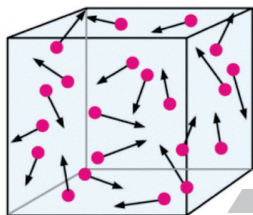

Unit - 9

Kinetic Theory Of Gases

9.1 Kinetic Theory of Gases : Assumption

- (1) The molecules of a gas are identical, spherical and perfectly elastic point masses.
- (2) The volume of molecules is negligible in comparison to the volume of gas.
- (3) Molecules of a gas moves randomly in all direction.
- (4) The speed of gas molecules lie between zero and infinity.
- (5) Their collisions are perfectly elastic.
- (6) The number of collisions per unit volume in a gas remains constant.
- (7) No attractive or repulsive force acts between gas molecules.

9.2 Pressure of an ideal Gas

$$P = \frac{1}{3} \rho V_{\text{rms}}^2 \quad \text{or} \quad P = \frac{1}{3} \frac{mN}{V} V_{\text{rms}}^2$$

$$\left[\text{rms velocity of the gas molecule } V_{\text{rms}} = \sqrt{\frac{V_1^2 + V_2^2 + V_3^2 + V_4^2 + \dots}{N}} \right]$$

Relation between pressure and kinetic energy

$$\therefore \text{K.E. per unit volume (E)} = \frac{1}{2} \left(\frac{M}{V} \right) V_{\text{rms}}^2 = \frac{1}{2} \rho V_{\text{rms}}^2 \quad P = \frac{2}{3} E$$

9.3 Ideal Gas Equation

The equation which relates the pressure (P), volume (V) and temperature (T) of the given state of an ideal gas is known as gas equation.

For 1 mole or N_A molecule or M gram or 22.4 litres of gas	$PV = RT$
For μ mole of gas	$PV = \mu RT$
For 1 molecule of gas	$PV = \left(\frac{R}{N_A}\right)T = kT$
For N molecules of gas	$PV = NkT$
For 1 gm of gas	$PV = \left(\frac{R}{M}\right)T = rT$
for n gm of gas	$Pv = nrT$

(1) **Universal gas constant (R)** : Dimension $[ML^2T^{-2}\theta^{-1}]$

Thus universal gas constant signifies the work done by (or on) a gas per mole per kelvin.

$$\text{S.T.P value : } 8.31 \frac{\text{Joule}}{\text{Mole} \times \text{kelvin}} = 1.98 \frac{\text{cal}}{\text{mole} \times \text{kelvin}}$$

(2) **Boltzman's constant (k)** : Dimension $[ML^2T^{-2}\theta^{-1}]$

$$k = 1.38 \times 10^{-23} \text{ Joule/kelvin}$$

9.4 Various Speeds of Gas Molecules

$$(1) \text{ Root mean square speed } V_{\text{rms}} = \sqrt{\frac{3P}{\rho}} = \sqrt{\frac{3RT}{M}} = \sqrt{\frac{3kT}{m}}$$

$$(2) \text{ Most probable speed } V_{\text{mp}} = \sqrt{\frac{2P}{\rho}} = \sqrt{\frac{2RT}{M}} = \sqrt{\frac{2kT}{m}}$$

$$(3) \text{ Average speed } V_{\text{av}} = \sqrt{\frac{8P}{\pi\rho}} = \sqrt{\frac{8RT}{\pi M}} = \sqrt{\frac{8kT}{\pi m}}$$

- $V_{\text{rms}} > V_{\text{av}} > V_{\text{mp}}$ (remembering trick) (RAM)

9.5 Kinetic Energy of Ideal Gas

Molecules of ideal gases possess only translational motion. So they possess only translational kinetic energy.

Quantity of gas	Kinetic energy
Kinetic energy of a gas molecule (Emolecule)	$= \frac{1}{2}mv_{\text{rms}}^2 = \frac{1}{2}m\left(\frac{3kT}{m}\right) = \frac{3}{2}kT$ [As $v_{\text{rms}} = \sqrt{\frac{3kT}{m}}$]
Kinetic energy of 1 mole (M gram) gas (Emole)	$= \frac{1}{2}Mv_{\text{rms}}^2 = \frac{1}{2}M\frac{3RT}{m} = \frac{3}{2}RT$ [As $v_{\text{rms}} = \sqrt{\frac{3RT}{M}}$]
Kinetic energy of 1 gm gas (Egram)	$= \frac{3}{2}\frac{R}{M}T = \frac{3}{2}\frac{kN_A}{mN_A}T = \frac{3}{2}\frac{k}{m}T = \frac{3}{2}rT$

Here m = mass of each molecule, M = Molecular weight of gas and N_A – Avogadro number = 6.023×10^{23} .

9.6 Degree of Freedom

The total number of independent modes (ways) in which a system can possess energy is called the degree of freedom (f).

The degree of freedom are of three types :

- (i) Translational degree of freedom
- (ii) Rotational degree of freedom
- (iii) Vibrational degree of freedom

General expression for degree of freedom

$f = 3N - R$, where N = Number of independent particles, R = Number of independent restriction

- (1) **Monoatomic gas** : It can have 3 degrees of freedom (all translational).
- (2) **Diatomic gas** : A diatomic molecule has 5 degree of freedom : 3 translational and 2 rotational.
- (3) **Triatomic gas (Non-linear)** : It has 6 degrees of freedom : 3 translational and 3 rotational.

(4) Tabular display of degree of freedom of different gases

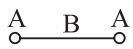
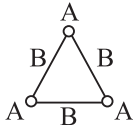
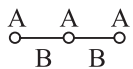
Atomicity of gas	Example	N	R	$f = 3N - R$	Figure
Monoatomic	He, Ne, Ar	1	0	$f = 3$	
Diatomic	H ₂ , O ₂	2	1	$f = 5$	
Triatomic non linear	H ₂ O	3	3	$f = 6$	
Triatomic linear	CO ₂ , BeCl ₂	3	2	$f = 7$	

- The above degrees of freedom are shown at room temperature. Further at high temperature the molecule will have an additional degrees of freedom, due to vibrational motion.

9.7 Law of Equipartition of Energy

For any system in thermal equilibrium, the total energy is equally distributed among its various degree of freedom. And the energy associated with each

molecule of the system per degree of freedom of the system is $\frac{1}{2}kT$.

9.8 Mean Free Path

The average distance travelled by a gas molecule is known as mean free path.

Let $\lambda_1, \lambda_2, \lambda_3, \dots, \lambda_n$ be the distance travelled by a gas molecule during n collisions respectively, then the mean free path of a gas molecule is given by

$$\lambda = \frac{\lambda_1 + \lambda_2 + \lambda_3 + \dots + \lambda_n}{n}$$

$\lambda_1 = \frac{1}{\sqrt{2}\pi n d^2}$; where d = Diameter of the molecule, n = Number of molecules per unit volume.

9.9 Specific heat or Specific Heat Capacity

- (1) **Gram specific heat** : It is defined as the amount of heat required to raise the temperature of unit gram mass of the substance by unit degree. Gram

$$\text{specific heat } c = \frac{\Delta Q}{m\Delta T}.$$

- (2) **Molar specific heat** : It is defined as the amount of heat required to raise the temperature of one gram mole of the substance by a unit degree, it is represented by capital (C)

$$C = \frac{Q}{\mu\Delta T}$$
$$C = Mc = \frac{1}{\mu} \frac{\Delta Q}{\Delta T} \quad \left[\text{As } \mu = \frac{m}{M} \right]$$

9.10 Specific Heat of Gases

- (i) In adiabatic process *i.e.*, $\Delta Q = 0$,

$$\therefore C = \frac{\Delta Q}{m(\Delta T)} = 0 \text{ i.e., } C = 0$$

- (ii) In isothermal process *i.e.*, $\Delta T = 0$

$$\therefore C = \frac{\Delta Q}{m(\Delta T)} = \frac{\Delta Q}{0} = \infty \text{ i.e., } C = \infty$$

Specific heat of gas can have any positive value ranging from zero to infinity. Further it can even be negative. Out of many values of specific heat of a gas, two are of special significance.

- (1) **Specific heat of a gas at constant volume (C_v)** : It is defined as the quantity of heat required to raise the temperature of unit mass of gas through 1 K when its volume is kept constant.
- (2) **Specific heat of a gas at constant pressure (C_p)** : It is defined as the quantity of heat required to raise the temperature of unit mass of gas through 1 K when its pressure is kept constant.

9.11 Mayer's Formula

$$C_p - C_v = R$$

This relation is called Mayer's formula and shows that $C_p > C_v$ *i.e.*, molar specific heat at constant pressure is greater than that at constant volume.

9.12 Specific Heat in Terms of Degree of Freedom

Specific heat and kinetic energy for different gases

		Monoatomic	Diatomic	Triatomic non-linear	Triatomic linear
Atomicity	A	1	2	3	3
Restriction	B	0	1	3	2
Degree of freedom	$f = 3A - B$	3	5	6	7
Molar specific heat at constant volume	$C_v = \frac{f}{2}R = \frac{R}{\gamma-1}$	$\frac{3}{2}R$	$\frac{5}{2}R$	3R	$\frac{7}{2}R$
Molar specific heat at constant pressure	$C_p = \left(\frac{f}{2} + 1\right)R = \left(\frac{\gamma}{\gamma-1}\right)R$	$\frac{5}{2}R$	$\frac{7}{2}R$	4R	$\frac{9}{2}R$
Ratio of C_p and C_v	$\gamma = \frac{C_p}{C_v} = 1 + \frac{2}{f}$	$\frac{5}{3} = 1.66$	$\frac{7}{5} = 1.4$	$\frac{4}{3} = 1.33$	$\frac{9}{7} = 1.28$
Kinetic energy of 1 mole	$E_{\text{mole}} = \frac{f}{2}RT$	$\frac{3}{2}RT$	$\frac{5}{2}RT$	3RT	$\frac{7}{2}RT$
Kinetic energy of 1 molecule	$E_{\text{molecule}} = \frac{f}{2}kT$	$\frac{3}{2}kT$	$\frac{5}{2}kT$	3kT	$\frac{7}{2}kT$
Kinetic energy of 1 gm	$E_{\text{gram}} = \frac{f}{2}rT$	$\frac{3}{2}rT$	$\frac{5}{2}rT$	3rT	$\frac{7}{2}rT$

QUESTIONS

VERY SHORT ANSWER TYPE QUESTIONS (1 MARK)

- Write two conditions when real gases obey the ideal gas equation ($PV = nRT$). $n \rightarrow$ number of mole.

2. If the number of molecule in a container is doubled. What will be the effect on the rms speed of the molecules ?
3. Draw the graph between P and $1/V$ (reciprocal of volume) for a perfect gas at constant temperature.
4. Name the factors on which the degree of freedom of gas depends.
5. What is the volume of a gas at absolute zero of temperature ?
6. How much volume does one mole of a gas occupy at STP ?
7. What is an ideal gas ?
8. The absolute temperature of a gas is increased 3 times what is the effect on the root mean square velocity of the molecules ?
9. What is the Kinetic energy per unit volume of a gas whose pressure is P ?
10. A container has equal number of molecules of hydrogen and carbon dioxide. If a fine hole is made in the container, then which of the two gases shall leak out rapidly ?
11. What is the mean translational Kinetic energy of a perfect gas molecule at T temperature ?
12. Why it is not possible to increase the temperature of a gas while keeping its volume and pressure constant.

SHORT ANSWER TYPE QUESTIONS (2 MARKS)

13. When an automobile travels for a long distance the air pressure in the tyres increases. Why ?
14. A gas storage tank has a small leak. The pressure in the tank drop more quickly if the gas is hydrogen than if it is oxygen. Why ?
15. Why the land has a higher temperature than the ocean during the day but a lower temperature at night.
16. Helium is a mixture of two isotopes having atomic masses 3g/mol and 4g/mol. In a sample of helium gas, which atoms move faster on average ?
17. State Avogadro's law. Deduce it on the basis of Kinetic theory of gases.
18. Although the velocity of air molecules is nearly 0.5 km/s yet the smell of scent spreads at a much slower rate why.
19. The root mean square (rms) speed of oxygen molecule at certain temperature 'T' is 'V'. If temperature is doubled and oxygen gas dissociates into atomic oxygen what is the speed of atomic oxygen ?

20. Two vessels of the same volume are filled with the same gas at the same temperature. If the pressure of the gas in these vessels be in the ratio 1 : 2 then state
- The ratio of the rms speeds of the molecules.
 - The ratio of the number of molecules.
21. Why gases at high pressure and low temperature show large deviation from ideal gas behaviour ?
22. A gas is filled in a cylinder fitted with a piston at a definite temperature and pressure. Why the pressure of the gas decreases when the piston is pulled out.

SHORT ANSWER TYPE QUESTIONS (3 MARKS)

23. On what parameters does the λ (mean free path) depends.
24. Equal masses of oxygen and helium gases are supplied equal amount of heat. Which gas will undergo a greater temperature rise and why ?
25. Why evaporation causes cooling ?
26. Two thermally insulated vessels 1 and 2 are filled, with air at temperatures (T_1, T_2), volume (V_1, V_2) at pressure (P_1, P_2) respectively. If the valve joining the two vessels is opened what is temperature of the vessel at equilibrium ?
27. A partition divides a container having insulated walls into two compartments I and II. The same gas fills the two compartment. What is the ratio of the number of molecules in compartments I and II ?

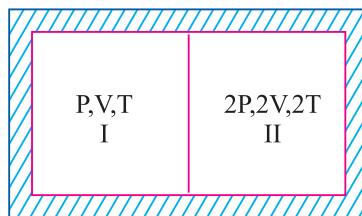

28. Prove that for a perfect gas having n degree of freedom

$$\frac{C_p}{C_v} = 1 + \frac{2}{n}$$

where C_p and C_v have their usual meaning.

29. The ratio of specific heat capacity at constant pressure to the specific heat capacity at constant volume of a diatomic gas decreases with increase in temperature. Explain.

30. Isothermal curves for a given mass of gas are shown at two different temperatures T_1 and T_2 state whether $T_1 > T_2$ or $T_2 > T_1$ justify your answer.

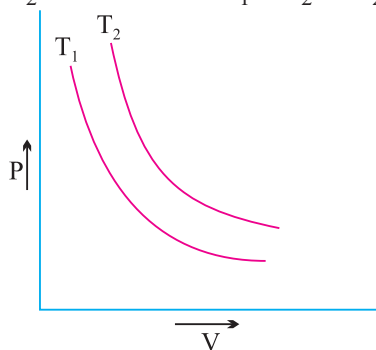

31. Three vessels of equal capacity have gases at the same temperature and pressure. The first vessel contains neon (monatomic) the second contains chlorine (diatomic) and the third contains uranium hexafluoride (polyatomic). Do the vessels contain equal number of respective molecules ? Is the root mean square speed of molecules the same in the three cases ? If not in which case is V_{rms} the largest ?
32. State Graham's law of diffusion. How do you obtain this from Kinetic Theory of gases.

LONG ANSWER TYPE QUESTIONS (5 MARKS)

33. What are the basic assumptions of kinetic theory of gases ? On their basis derive an expression for the pressure exerted by an ideal gas.
34. What is meant by mean free path of a gas molecule ? Derive an expression for it.
35. Given that $P = \frac{1}{3} \rho c^2$ where P is the pressure, ρ is the density and c is the rms. Velocity of gas molecules. Deduce Boyle's law and Charles law of gases from it.
36. What do you understand by mean speed, root mean square speed and most probable speed of a gas. The velocities of ten particles in m/s are 0, 2, 3, 4, 4, 4, 5, 5, 6, 9 calculate.
- Average speed
 - r.m.s. speed
37. What is law of equipartition of energy ? Find the value of $\gamma = C_p/C_v$ for diatomic and monatomic gas. Where symbol have usual meaning.

NUMERICALS

38. An air bubble of volume 1.0 cm^3 rises from the bottom of a lake 40 m deep at a temperature of 12°C . To what volume does it grow when it reaches the surface which is at a temperature of 35°C ?
39. A vessel is filled with a gas at a pressure of 76 cm of mercury at a certain temperature. The mass of the gas is increased by 50% by introducing more gas in the vessel at the same temperature. Find out the resultant pressure of the gas.
40. One mole of a monoatomic gas is mixed with three moles of a diatomic gas. What is the molecular specific heat of the mixture at constant volume ?
Take $R = 8.31/\text{mol}^{-1} \text{ K}^{-1}$.
41. An oxygen cylinder of volume 30 litre has an initial gauge pressure of 15 atmosphere and a temperature of 27°C . After some oxygen is withdrawn from the cylinder, the gauge pressure drops to 11 atmosphere and its temperature drop to 17°C . Estimate the mass of oxygen taken out of the cylinder.
($R = 8.31/\text{mol}^{-1} \text{ K}^{-1}$)
(molecular mass of $\text{O}_2 = 32$)
42. At what temperature the rms speed of oxygen atom equal to r.m.s. speed of helium gas atom at -10°C ?
Atomic mass of helium = 4
Atomic mass of oxygen = 32
43. Estimate the total number of molecules inclusive of oxygen, nitrogen, water vapour and other constituents in a room of capacity 25.0 m^3 at a temperature of 27°C and 1 atmospheric pressure.
44. 0.014 kg of nitrogen is enclosed in a vessel at a temperature of 27°C . How much heat has to be transferred to the gas to double the rms speed of its molecules.

OBJECTIVE QUESTIONS

45. At what temperature is the rms velocity of hydrogen molecule equal to that of an oxygen molecule at 47°C .
- (a) -73K (b) 3K
(c) 20K (d) 80K

46. The average kinetic energy of a gas molecule at 27°C is $621 \times 10^{-1} \text{ J}$. The average kinetic energy of gas molecule at 227°C will be
- (a) $52.2 \times 10^{-21} \text{ J}$ (b) $5.22 \times 10^{-21} \text{ J}$
 (c) $10.35 \times 10^{-21} \text{ J}$ (d) $11.35 \times 10^{-21} \text{ J}$
47. The equation of state 5 g of oxygen at a pressure P and temperature T, when occupying a volume V, will be
- (a) $PV = \frac{5RT}{32}$ $PV =$ $PV =$ (b) $PV = \frac{5RT}{16}$
 (c) $PV = \frac{5RT}{2}$ (d) $PV = 5RT$
48. A gas is found to obey the law $P^2 V = \text{constant}$. The initial temperature and volume are T_0 and V_0 . If the gas expands to a volume $3V_0$. Its final temperature becomes :
- (a) $\frac{T_0}{3}$ (b) $\frac{T_0}{\sqrt{3}}$
 (c) $3T_0$ (d) $\sqrt{3}T_0$
49. A gas behaves as an ideal gas at
- (a) low pressure and high temperature
 (b) low pressure and low temperature
 (c) high pressure and low temperature
 (d) high pressure and high temperature
50. If γ is the ratio of specific heats of a perfect gas, the no. of degrees of freedom of a molecule of the gas is
- (a) $25 \frac{(\gamma-1)}{2}$ (b) $9 \frac{(\gamma-1)}{2}$
 (c) $\frac{3\gamma-1}{2\gamma-1}$ (d) $\frac{2}{\gamma-1}$
51. A gas is filled in a container at pressure P_0 . If the mass of molecules is halved and their rms speed is doubled. The resultant pressure would be
- (a) $2P_0$ (b) $4P_0$
 (c) $\frac{P_0}{4}$ (d) $\frac{P_0}{2}$

52. The translational kinetic energy of gas molecules for 1 mol of gas is equal to
- (a) $\frac{3}{2}RT$ (b) $\frac{2KT}{3}$
(c) $\frac{RT}{2}$ (d) $\frac{3KT}{2}$
53. Molecular motion shows itself as
- (a) Temperature (b) Internal energy
(c) Friction (d) Viscosity
54. A sample of gas is at 0°C . To what temperature it must be raised in order to double the rms speed of the molecule
- (a) 270°C (b) 719°C
(c) 1090°C (d) 100°C
55. The work done by (or on) a gas per mole per kelvin is called
- (a) Universal gas constant (b) Boltzmann's constant
(c) Gravitational constant (d) Entropy
56. A gas filled in a closed vessel is heated through 1 K and its pressure increases by 0.4%. What was the initial temperature of the gas?
- (a) 250 K (b) 350 K
(c) 450 K (d) 500 K
57. The root mean square speed of the molecules of a gas is
- (a) independent of its pressure but directly proportional to its Kelvin temperature
(b) directly proportional to two square root of both its pressure and its Kelvin temperature
(c) independent of its pressure but directly proportional to the square root of its Kelvin temperature.
(d) directly proportional to its pressure and its Kelvin temperature.

ASSERTION - REASON BASED QUESTIONS

Direction:- Read the assertion and reason carefully to mark the correct option out of the options given below :

- (a) If both assertion and reason are true and the reason is the correct explanation of the assertion.
- (b) If both assertion and reason are true but reason is not the correct explanation of the assertion.
- (c) If assertion is true but reason is false.
- (d) If the assertion and reason both are false.
- (e) If assertion is false but reason is true.

1. Assertion: If a gas container in motion is suddenly stopped, the temperature of the gas rises.

Reason: The kinetic energy of ordered mechanical motion is converted into the kinetic energy of random motion of gas molecules.

2. Assertion: The total translational kinetic energy of all the molecules of a given mass of an ideal gas is 1.5 times the product of its pressure and its volume.

Reason: The molecules of a gas collide with each other and the velocities of the molecules change due to collision.

3. Assertion: Gases do not settle to the bottom of a container.

Reason: Gases have high kinetic energy.

4. Assertion: A gas have a unique value of specific heat.

Reason: Specific heat is defined as the amount of heat required to raise the temperature of unit mass of the substance through unit degree.

5. Assertion: A gas can be liquified at any temperature by increase of pressure alone.

Reason: On increasing pressure the temperature of gas decreases.

6. Assertion: Equal masses of helium and oxygen gases are given equal quantities of heat. There will be a greater rise in the temperature of helium compared to that of oxygen .

Reason: The molecular weight of oxygen is more than the molecular weight of helium.

7. Assertion: Absolute zero is the temperature corresponding to zero energy.

Reason: The temperature at which no molecular motion cease is called absolute zero temperature.

8. Assertion: The ratio of specific heat gas at constant pressure and specific heat at constant volume for a diatomic gas is more than that for a monatomic gas.
Reason: The molecules of a monatomic gas have more degree of freedom than those of a diatomic gas.
9. Assertion: At room temperature, water does not sublime from water to steam.
Reason: The critical point of water is much above the room temperature.
10. Assertion: Specific heat of a gas at constant pressure (C_p) is greater than its specific heat at constant volume (C_v) .
Reason: At constant pressure, some heat is spent in expansion of the gas.
11. Assertion: The internal energy of a real gas is function of both, temperature and volume.
Reason: Internal kinetic energy depends on temperature and internal potential energy depends on volume.

CASE STUDY BASED QUESTIONS

The equipartition of kinetic energy was proposed initially in 1843 and more correctly in 1845, by John James Waterston. In 1859, James Clerk Maxwell argued that the kinetic heat energy of a gas is equally divided between linear and rotational energy. In 1876, Ludwig Boltzmann expanded on this principle by showing that the average energy was divided equally among all the independent components of motion in a system. Boltzmann applied the equipartition theorem to provide a theoretical explanation of the Dulong-Petit law for the specific heat capacities of solids.

Law of Equipartition of Energy

According to this law, for any system in thermal equilibrium, the total energy is equally distributed among its various degree of freedom. And each degree of freedom is associated with energy $\frac{1}{2}kT$ (where $k = 1.3 \times 10^{-23} \text{J/K}$, $T =$ absolute temperature of the system).

At a given temperature T ; all ideal gas molecules no matter what their mass have th same average translational kinetic energy; namely, $\frac{3}{2}kT$.
When measure the temperature of a gas, we are also measuring the average

translational kinetic energy of its molecules.

At same temperature gases with different degrees of freedom (e.g., He, and H) will have different average energy or internal energy namely $\frac{f}{2}kT$. (F is different for different gases)

Answer the following questions

- Relation between pressure P and average kinetic energy E per unit volume of a gas is
(a) $P = \frac{2E}{3}$ (b) $P = \frac{E}{3}$ (c) $P = \frac{3E}{2}$ (d) $P = 3E$
- At 0 K, which of the following properties of a gas will be zero?
(a) kinetic energy (b) potential energy
(c) vibrational energy (d) density
- The root mean square velocity of a gas molecule of mass m at a given temperature is proportional to
(a) m^0 (b) m (c) \sqrt{m} (d) $m^{-1/2}$
- An ant is walking on the horizontal surface. The number of degrees of freedom of ant will be
(a) 1 (b) 2 (c) 3 (d) 6
- The number of degrees of freedom for a diatomic gas molecule is
(a) 2 (b) 3 (c) 5 (d) 6

ANSWERS

VERY SHORT ANSWERS (1 MARK)

1. (i) Low pressure (ii) High temperature.

2. No effect

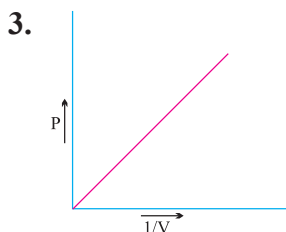

4. Atomicity and temperature.

5. 0

6. 22.4 litre
7. Gas in which intermolecular forces are absent.
8. increases $\sqrt{3}$ times
9. $3P/2$
10. Hydrogen (rms speed is greater)
11. $\frac{3}{2}RT$
12. $P = \frac{1}{3} \frac{M}{V} KT, \quad T \propto (PV)$

P and V are constant then T is also constant.

SHORT ANSWERS (2 MARKS)

13. Work is done against friction. This work done is converted into heat. Temperature rises. $PV = nRT$, As volume of tyre is const. $P \propto T$.
14. Rate of diffusion of a gas is inversely proportional to the square root of the density. So hydrogen leaked out more rapidly.
15. Specific Heat of water is more than land (earth). Therefore for given heat change in temp. of land is more than ocean (water).
19. $c = \sqrt{\frac{3RT}{M}} = v, c' = \sqrt{\frac{3R(2T)}{M/2}} = 2\sqrt{\frac{3RT}{M}}$
 $c' = 2v$
20. (i) $C \propto \sqrt{T}$
 as the temperature is same rms speeds are same.
 (ii) $P = \frac{1}{3} \frac{mnc^2}{V} \Rightarrow P_1 = \frac{1}{3} \frac{mn_1c^2}{V}, P_2 = \frac{1}{3} \frac{mn_2c^2}{V}$
i.e., $\frac{P_1}{P_2} = \frac{n_1}{n_2} = \frac{1}{2}$
21. When temperature is low and pressure is high the intermolecular forces become appreciable thus the volume occupied by the molecular is not negligibly small as composed to volume of gas.
22. When piston is pulled out the volume of the gas increases, Now losses number

of molecules colliding against the wall of container per unit area decreases. Hence pressure decreases.

ANSWERS (3 MARKS)

23. (i) diameter of molecule as $\lambda \propto \frac{1}{d^2}$

(ii) Pressure of gas as $\lambda \propto \frac{1}{P}$

24. Heat supplied to oxygen = Heat supplied to Helium

$$mc_1\Delta T_1 = mc_2\Delta T_2$$

$$\frac{\Delta T_1}{\Delta T_2} = \frac{c_2}{c_1}, \text{ As } c \propto \frac{1}{m}, m = \text{molecular mass}$$

$$\frac{\Delta T_1}{\Delta T_2} = \frac{c_2}{c_1} = \frac{m_1}{m_2}, \text{ As } m_1 > m_2$$

$$\Delta T_1 > \Delta T_2$$

25. During evaporation fast moving molecules escape a liquid surface so the average kinetic energy of the molecules left behind is decreased thus the temperature of the liquid is lowered.

26. number of mole = Constant

$$\mu_1 + \mu_2 = \mu$$

$$\frac{P_1 V_1}{RT_1} + \frac{P_2 V_2}{RT_2} = \frac{P(V_1 + V_2)}{RT}$$

From Boyle's law, $P(V_1 + V_2) = P_1 V_1 + P_2 V_2$

27. $n = \frac{pV}{kT}, n' = \frac{2p2V}{kT}$

$$n/n' = \frac{1}{4}$$

30. $T = \frac{PV}{\mu R}, T \propto PV [\mu R = \text{constant}]$

Since PV is greater for the curve at T_2 than for the curve T_1 therefore $T_2 > T_1$.

31. Three vessels at the same pressure and temperature have same volume and contain equal number of molecules.

$$V_{\text{rms}} = \sqrt{\frac{3RT}{m}}, \quad V_{\text{rms}} \propto \frac{1}{\sqrt{m}}$$

rms speed will not same, neon has smallest mass therefore rms speed will be largest for neon.

38. $V_1 = 10^{-6} \text{ m}^3$

$$\begin{aligned} \text{Pressure on bubble } P_1 &= \text{Water pressure} + \text{Atmospheric pressure} \\ &= pgh + P_{\text{atm}} \\ &= 4.93 \times 10^5 \text{ Pa} \end{aligned}$$

$$T_1 = 285 \text{ K}, T_2 = 308 \text{ K}$$

$$\frac{P_1 V_1}{T_1} = \frac{P_2 V_2}{T_2}$$

$$V_2 = \frac{4.93 \times 10^5 \times 1 \times 10^{-6} \times 308}{285 \times 1.01 \times 10^5} = 5.3 \times 10^{-6} \text{ m}^3.$$

39. According to kinetic theory of gases,

$$PV = \frac{1}{3} m v_{\text{rms}}^2$$

At constant temperature, v_{rms}^2 is constant. As v is also constant, so $P \propto m$.

When the mass of the gas increase by 50% pressure also increases by 50%,

$$\therefore \text{Final pressure} = 76 + \frac{50}{100} \times 76 = 114 \text{ cm of Hg.}$$

40. For monoatomic gas, $C_v = \frac{3}{2} R, n = 1 \text{ mole}$

For diatomic gas, $C_v' = \frac{5}{2} R, n' = 3 \text{ mole}$

From conservation of energy, the molecular specific heat of the mixture is

$$\begin{aligned} C_v' &= \frac{n(C_v) + n'(C_v')}{(n + n')} \\ &= \frac{1 \times \frac{3}{2} R + 3 \times \frac{5}{2} R}{(1 + 3)} = \frac{9}{4} R \end{aligned}$$

or

$$C_v' = \frac{9}{4} \times 8.31 = 18.7 \text{ J mol}^{-1} \text{ K}^{-1}.$$

41. $V_1 = 30 \text{ litre} = 30 \times 10^3 \text{ cm}^3 = 3 \times 10^{-2} \text{ m}^3$

$$P_1 = 15 \times 1.013 \times 10^5 \text{ N/m}^2$$

$$T_1 = 300 \text{ K}$$

$$\mu_1 = \frac{P_1 V_1}{RT_1} = 18.3$$

$$P_2 = 11 \times 1.013 \times 10^5 \text{ N/m}^2$$

$$V_2 = 3 \times 10^{-2} \text{ m}^3$$

$$T_2 = 290 \text{ K}$$

$$\mu_2 = \frac{P_2 V_2}{RT_2} = 13.9$$

$$\mu_2 - \mu_1 = 18.3 - 13.9 = 4.4$$

Mass of gas taken out of cylinder

$$= 4.4 \times 32 \text{ g}$$

$$= 140.8 \text{ g}$$

$$= 0.140 \text{ kg.}$$

$$42. \quad v_{\text{rms}} = \left[\frac{3PV}{M} \right]^{1/2} = \left[\frac{3RT}{M} \right]^{1/2}$$

Let r.m.s. speed of oxygen is $(v_{\text{rms}})_1$ and of helium is $(v_{\text{rms}})_2$ is equal at temperature T_1 and T_2 respectively.

$$\frac{(v_{\text{rms}})_1}{(v_{\text{rms}})_2} = \sqrt{\frac{M_2 T_1}{M_1 T_2}}$$

$$\left[\frac{4T_1}{32 \times 263} \right]^{1/2} = 1$$

$$T_1 = \frac{32 \times 263}{4} = 2104 \text{ K.}$$

43. As Boltzmann's constant,

$$k_B = \frac{R}{N}, \quad \therefore R = k_B N$$

$$\text{Now} \quad PV = nRT = nk_B NT$$

\therefore The number of molecules in the room

$$= nN = \frac{PV}{Tk_B}$$

$$= \frac{1.013 \times 10^5 \times 25.0}{300 \times 1.38 \times 10^{-23}} = 6.117 \times 10^{26}.$$

44. Number of mole in 0.014 kg of Nitrogen

$$n = \frac{0.014 \times 10^3}{28} = \frac{1}{2} \text{ mole}$$

$$C_v = \frac{5}{2}R = \frac{5}{2} \times 2 = 5 \text{ cal/mole } k$$

$$\frac{V_2}{V_1} = \sqrt{\frac{T_2}{T_1}}, \quad T_2 = 4T_1$$

$$\begin{aligned} \Delta T &= T_2 - T_1 = 4T_1 - T_1 = 3T_1 \\ &= 3 \times 300 = 900 \text{ K} \end{aligned}$$

$$\Delta Q = n c_v \Delta T = \frac{1}{2} \times 5 \times 900 = 2250 \text{ cal.}$$

ANSWER (OBJECTIVE TYPE QUESTIONS)

45. (c) 46. (c) 47. (a) 48. (d) 49. (a) 50. (d)
 51. (a) 52. (a) 53. (a) 54. (b) 55. (a) 56. (a)
 57. (c) 58. (b) 59. (c) 60. (a) 61. (a) 62. (b)
 63. (c) 64. (c)

HINTS :-

45. $v_1 = \sqrt{\frac{3RT_1}{M_1}}, \quad v_2 = \sqrt{\frac{3RT_2}{M_2}}$ i.e. $T_1 = \frac{M_1}{M_2} T_2 = \frac{2}{32} \times 320 = 20 \text{ k}$

46. $K_1 = \frac{3}{2} kT_1, \quad K_2 = \frac{3}{2} kT_2$ i.e. $\frac{K_1}{K_2} = \frac{T_1}{T_2} \Rightarrow K_2 = \frac{K_1 T_2}{T_1} = \frac{621 \times 10^{-21}}{300} \times 500 = 10.35 \times 10^{-21} \text{ J}$

48. $P^2 V = \text{constant} \Rightarrow \left(\frac{RT}{V}\right)^2 V = \text{constant} \Rightarrow \frac{T^2}{V} = \text{constant.}$

50. $\gamma = 1 + \frac{1}{f}$

51. $P_0 = \frac{1}{3} \rho C^2$ As $\rho \rightarrow$ halved and C is doubled then $P' = 2P_0$

54. $C^2 \propto T$

55. $\frac{PV}{T} = R$

56. $PV = RT$ here $V = \text{Constant}$ therefore $P \propto T$. i.e. $= \frac{P}{T}$ constant

$$\frac{P_1}{T_1} = \frac{P_2}{T_2} \Rightarrow \frac{P}{T} = \frac{P + 0.4\% \text{ of } P}{T + 1} \Rightarrow T = 250 \text{ K}$$

58. $P \propto T$

60. $C_v = \frac{dU}{dT}$ and $U = \frac{3}{2} RT$

64. $V \propto T$ as P is constant.

ASSERTION - REASON BASED ANSWERS

1. (a) 2. (b) 3. (a) 4. (e) 5. (d) 6. (b)
7. (e) 8. (d) 9. (a) 10. (a) 11. (a)

HINTS :-

- (a) The motion of the container is known as the ordered motion of the gas and zig-zag motion of gas molecules within the container is called disordered motion. When the container suddenly stops, ordered kinetic energy gets converted into disordered kinetic energy which increases the temperature of the gas.
- (b) Average translational kinetic energy of a gas molecule is $E = \frac{3}{2} kT$
For all gas molecules $E = \frac{3}{2} kT \times N_A = \frac{3}{2} RT = \frac{3}{2} PV$
- (a) Gases do not settle to the bottom because of its kinetic energy. They are always in random motion. Because of the small mass, the effect of gravity on them is negligible.

CASE STUDY BASED ANSWERS

- (a) $P = \frac{2E}{3}$
- (a) At 0 K, all molecular motion stops, so kinetic energy becomes zero.
- (d) $V_{\text{rms}} = \sqrt{\frac{3K_3T}{m}}$ i.e. $V_{\text{rms}} \propto m^{-1/2}$
- (b) As the ant can move on a plane, it has 2 degree of freedom.
- (c) A diatomic molecule has 3 degree of freedom due to translatory motion and 2 degrees of freedom due to rotatory motion.

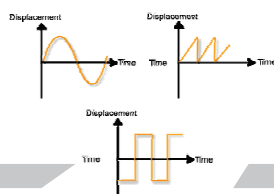

Unit -10-A

Mechanical Waves

Oscillation & Waves

10.1 Periodic Motion

A motion, which repeats itself over and over again after a regular interval of time is called a periodic motion and the fixed interval of time after which the motion is repeated is called period of the motion. *Examples* : Revolution of earth around the sun (period one year).

10.2 Oscillatory or Vibratory Motion.

The motion in which a body moves to and fro or back and forth repeatedly about a fixed point in a definite interval of time. Oscillatory motion is also called as harmonic motion. *Example* : The motion of the pendulum of a wall clock.

10.3 Harmonic and Non-harmonic Oscillation.

Harmonic oscillation is that oscillation which can be expressed in terms of single harmonic function (*i.e.* sine or cosine function). *Example* : $y = a \sin \omega t$ or $y = a \cos \omega t$.

Non-harmonic oscillation is that oscillation which can not be expressed in terms of single harmonic function. *Example* : $y = a \sin \omega t + b \sin 2 \omega t$.

10.4 Some Important Definitions.

- (1) **Time period** : It is the least interval of time after which the periodic motion of a body repeats itself. S.I. units of time period is second.
- (2) **Frequency** : It is defined as the number of periodic motions executed by body per second. S.I unit of frequency is hertz (Hz).
- (3) **Angular Frequency** : $\omega = 2\pi n$
- (4) **Displacement**: Its deviation from the mean position.

- (5) **Phase** : It is a physical quantity, which completely express the position and direction of motion, of the particle at that instant with respect to its mean position.

$Y = a \sin \theta = a \sin (\omega t + \phi_0)$ here $\theta = \omega t + \phi_0 =$ phase of vibrating particle.

- (i) **Initial phase or epoch** : It is the phase of a vibrating particle at $t = 0$.
- (ii) **Same phase**: Two vibrating particle are said to be in same phase, if the phase difference between them is an even multiple of n or path difference is an even multiple of $(\lambda/2)$ or time interval is an even multiple of $(T/2)$.
- (iii) **Opposite phase** : Opposite phase means the phase difference between the particle is an odd multiple of π or the path difference is an odd multiple of λ or the time interval is an odd multiple of $(T/2)$.
- (iv) **Phase difference** : If two particles performs S.H.M and their equation are $y_1 = a \sin (\omega t + \phi_1)$ and $y_2 = a \sin (\omega t + \phi_2)$ then phase difference $\Delta\phi = (\omega t + \phi_2) - (\omega t + \phi_1) = \phi_2 - \phi_1$

10.5 Simple Harmonic Motion.

Simple harmonic motion is a special type of periodic motion, in which Restoring force \propto Displacement of the particle from mean position.

$$F = -kx$$

Where k is known as force constant. Its S.I. unit is Newton/meter and dimension is $[MT^{-2}]$.

10.6 Displacement in S.H.M.

Simple harmonic motion is defined as the projection of uniform circular motion on any diameter of circle of reference

- (i) $y = a \sin \omega t$ when at $t = 0$ the vibrating particle is at mean position.
- (ii) $y = a \cos \omega t$ when at $t = 0$ the vibrating particle is at extreme position.
- (iii) $y = a \sin (\omega t \pm \phi)$ when the vibrating particle is ϕ phase leading or lagging from the mean position.

10.7 Comparative Study of Displacement, Velocity and Acceleration.

Displacement $y = a \sin \omega t$

Velocity $v = a\omega \cos \omega t$

$$\omega t = a\omega \sin\left(\omega t + \frac{\pi}{2}\right)$$

Acceleration $A = -a\omega^2 \sin \omega t$

$$\omega t = a\omega^2 \sin(\omega t + \pi)$$

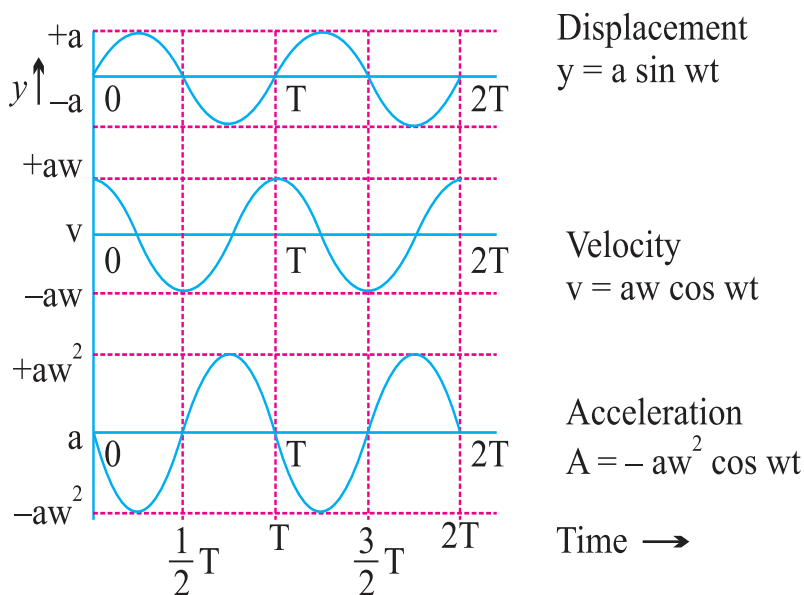

- (i) All the three quantities displacement, velocity and acceleration show harmonic variation with time having same period.
- (ii) The velocity amplitude is ω times the displacement amplitude
- (iii) The acceleration amplitude is ω^2 times the displacement amplitude
- (iv) In S.H.M. the velocity is ahead of displacement by a phase angle $\pi/2$.
- (v) In S.H.M. the acceleration is ahead of velocity by a phase angle $\pi/2$.
- (vi) The acceleration is ahead of displacement by a phase angle of π .
- (vii) Various physical quantities in S.H.M. at different position :

Physical quantities	Equilibrium position ($y = 0$)	Extreme Position ($y = \pm a$)
Displacement $y = a \sin \omega t$	Minimum (Zero)	Maximum (a)
Velocity $v = \omega\sqrt{a^2 - y^2}$	Maximum ($a\omega$)	Minimum (Zero)
Acceleration $A = -\omega^2 y$	Minimum (Zero)	Maximum ($\omega^2 a$)

10.8 Energy in S.H.M.

A particle executing S.H.M. possesses two types of energy : Potential energy and Kinetic energy

(1) **Potential energy :** $U = \frac{1}{2}m\omega^2 a^2 \sin^2 \omega t$

(i) $U_{\max} = \frac{1}{2}ka^2 = \frac{1}{2}m\omega^2 a^2$ when $y = \pm a$; $\omega t = \pi/2$; $t = T/4$

(ii) $U_{\min} = 0$ when $y = 0$; $\omega t = 0$; $t = 0$

(2) **Kinetic energy :**

$$K = \frac{1}{2}ma^2\omega^2 \cos^2 \omega t \text{ or } K = \frac{1}{2}m\omega^2(a^2 - y^2)$$

(i) $K_{\max} = \frac{1}{2}m\omega^2 a^2$ when $y = 0$; $t = 0$; $\omega t = 0$

(ii) $K_{\min} = 0$ when $y = a$; $t = T/4$, $\omega t = \pi/2$

(3) **Total energy :** Total mechanical energy

$$= \text{Kinetic energy} + \text{Potential energy}$$

$$E = \frac{1}{2}m\omega^2 a^2$$

Total energy is not a position function *i.e.* it always remains constant.

(4) **Energy position graph :**

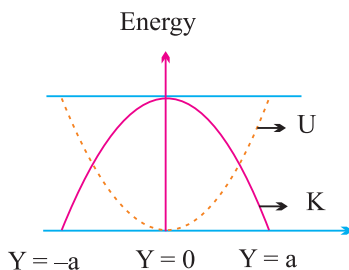

- (5) Kinetic energy and potential energy vary periodically double the frequency of S.H.M.

10.9 Time Period and Frequency of S.H.M.

$$\text{Time period (T)} = \frac{2\pi}{\omega} = 2\pi\sqrt{\frac{m}{k}} \quad \text{as } \omega = \sqrt{\frac{k}{m}}$$

$$\text{Frequency (n)} = \frac{1}{T} = \frac{1}{2\pi}\sqrt{\frac{k}{m}}$$

In general m is called inertia factor and k is called spring factor.

$$\text{Thus } T = 2\pi\sqrt{\frac{\text{Inertia factor}}{\text{Spring factor}}}$$

10.10 Differential Equation of S.H.M.

$$\text{For S.H.M. (linear) } m\frac{d^2y}{dt^2} + ky = 0 \quad [\text{As } \omega = \sqrt{\frac{k}{m}}]$$

$$\text{For angular S.H.M. } \frac{d^2\theta}{dt^2} + \omega^2\theta = 0 \quad [\omega^2 = \frac{k}{m}]$$

10.11 Simple Pendulum

Mass of the bob = m

$$\text{Effective length of simple pendulum} = l; T = 2\pi\sqrt{\frac{l}{g}}$$

- (i) Time period of simple pendulum is independent of amplitude as long as its motion is simple harmonic.
- (ii) Time period of simple pendulum is also independent of mass of the bob.
- (iii) If the length of the pendulum is comparable to the radius of earth

$$\text{then } T = 2\pi\sqrt{\frac{1}{g\left[\frac{1}{l} + \frac{1}{R}\right]}}$$

$$\text{If } l \gg R \text{ (} \rightarrow \infty \text{) } 1/l < 1/R \text{ so } T = 2\pi\sqrt{\frac{R}{g}} \cong 84.6 \text{ minutes}$$

- (iv) The time period of simple pendulum whose point of suspension moving horizontally with acceleration,

$$a T = 2\pi \sqrt{\frac{l}{(g^2 + a^2)^{1/2}}} \quad \text{and} \quad \theta = \tan^{-1}(a/g)$$

- (v) Second's Pendulum : It is that simple pendulum whose time period of vibrations is two seconds.

- (vi) Work done in giving an angular displacement θ to the pendulum from its mean position.

$$W = U = mgl(1 - \cos \theta)$$

- (vii) Kinetic energy of the bob at mean position = work done or potential energy at extreme.

10.12 Spring Pendulum

A point mass suspended from a mass less spring or placed on a frictionless horizontal plane attached with spring constitutes a linear harmonic spring pendulum

$$\text{Time period } T = 2\pi \sqrt{\frac{\text{inertia factor}}{\text{spring factor}}}$$

$$T = 2\pi \sqrt{\frac{m}{k}} \quad \text{and} \quad \text{Frequency } n = \frac{1}{2\pi} \sqrt{\frac{k}{m}}$$

- (i) Time of a spring pendulum is independent of acceleration due to gravity.
 (ii) If the spring has a mass M and mass m is suspended from it, effective

$$\text{mass is given by } m_{\text{eff}} = m + \frac{M}{3}$$

$$\text{So that } T = 2\pi \sqrt{\frac{m_{\text{eff}}}{k}}$$

- (iii) If two masses of mass m_1 and m_2 are connected by a spring and made to oscillate on horizontal surface, the reduced mass m_r is given by



$$\frac{1}{m_r} = \frac{1}{m_1} + \frac{1}{m_2}$$

So that $T = 2\pi\sqrt{\frac{m_r}{k}}$

- (iv) If a spring pendulum, oscillating in a vertical plane is made to oscillate on a horizontal surface, (or on inclined plane) time period will remain unchanged.
- (v) If the stretch in a vertically loaded spring is y_0 then

$$T = 2\pi\sqrt{\frac{m}{k}} = 2\pi\sqrt{\frac{y_0}{g}}$$

Time period does not depend on 'g' because along with g, y_0 will also change in such a way that $\frac{y_0}{g} = \frac{m}{k}$ remains constant.

- (vi) Series combination : If n springs of different force constant are connected in series having force constant k_1, k_2, k_3, \dots respectively

then
$$\frac{1}{k_{eff}} = \frac{1}{k_1} + \frac{1}{k_2} + \frac{1}{k_3} + \dots$$

- (vii) Parallel combination: If the springs are connected in parallel then $k_{eff} = k_1 + k_2 + k_3 + \dots$

- (viii) If the spring of force constant k is divided into n equal parts then spring constant of each part will become nk .

- (ix) The spring constant k is inversely proportional to the spring length.

As $k \propto \frac{1}{\text{Extension}} \propto \frac{1}{\text{Length of spring}}$

- (x) When a spring of length l is cut into two pieces of length l_1 and l_2 such that $l_1 = nl_2$.

If the constant of a spring is k then spring constant of first part $k_1 = \frac{k(n+1)}{n}$

Spring constant of second part $k_2 = (n+1)k$ and ratio of spring constant

$$\frac{k_1}{k_2} = \frac{1}{n}.$$

10.13 Various Formulae of S.H.M. .

S.H.M. of a liquid in U tube :

If a liquid of density ρ contained in a vertical U tube performs S.H.M. in its two limbs. Then time period

$$T = 2\pi\sqrt{\frac{L}{2g}} = 2\pi\sqrt{\frac{h}{g}}$$

Where L = Total length of liquid column, H = Height of undisturbed liquid in each limb ($L = 2h$)

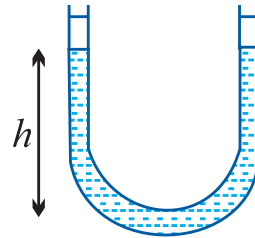

S.H.M. of a floating cylinder

If l is the length of cylinder dipping in liquid then time period

$$T = 2\pi\sqrt{\frac{l}{g}}$$

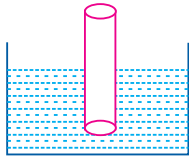

S.H.M. of ball in the neck of an air chamber

Image

$$T = \frac{2\pi}{A} \sqrt{\frac{mV}{E}}$$

M = mass of the ball

V = volume of air chamber

A = area of cross section of neck

E = Bulk modulus for Air

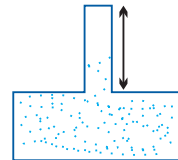

S.H.M. of a body in a tunnel dug along any chord of earth

$$T = 2\pi\sqrt{\frac{R}{g}} = 84.6 \text{ minutes}$$

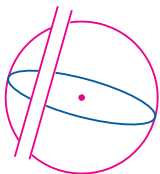

S.H.M. of body in the tunnel dug along the diameter of earth

$$T = 2\pi\sqrt{\frac{R}{g}}$$

$T = 84.6$ minutes

R = radius of the earth = 6400 km

g = acceleration due to gravity = 9.8 m/s² at earth's surface

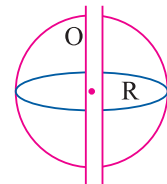

10.14 Free, Damped, Forced and Maintained Oscillation.

(1) Free oscillation

- (i) The oscillation of a particle with fundamental frequency under the influence of restoring force are defined as free oscillations
- (ii) The amplitude, frequency and energy of oscillation remains constant
- (iii) Frequency of free oscillation is called natural frequency.

(2) Damped oscillation

- (i) The oscillation of a body whose amplitude goes on decreasing with time are defined as damped oscillation.
- (ii) Amplitude of oscillation decreases exponentially due to damping forces like frictional force, viscous force, hysteresis etc.

(3) Forced oscillation

- (i) The oscillation in which a body oscillates under the influence of an external periodic force are known as forced oscillation.
- (ii) Resonance: When the frequency of external force is equal to the natural frequency of the oscillator. Then this state is known as the state of resonance. And this frequency is known as resonant frequency.

(4) Maintained oscillation : The oscillation in which the loss of oscillator is compensated by the supplying energy from an external source are known as maintained oscillation.

10.15 Wave

A wave is a disturbance which propagates energy and momentum from one place to the other without the transport of matter.

(1) Necessary properties of the medium for wave propagation :

- (i) *Elasticity* : So that particles can return to their mean position, after having been disturbed.
- (ii) *Inertia* : So that particles can store energy and overshoot their mean position.

(iii) Minimum friction amongst the particles of the medium.

(iv) Uniform density of the medium.

(2) Mechanical waves : The waves which require medium for their propagation are called mechanical waves.

Example : Waves on string and spring, waves on water surface, sound waves, seismic waves.

(3) Non-mechanical waves : The waves which do not require medium for their propagation are called non-mechanical or electromagnetic waves.

Examples : Light, heat (Infrared), radio waves, γ -rays. X-rays etc.

(4) Transverse waves : Particles of the medium execute simple harmonic motion about their mean position in a direction perpendicular to the direction of propagation of wave motion.

(i) It travels in the form of crests and troughs.

(ii) A crest is a portion of the medium which is raised temporarily.

(iii) A trough is a portion of the medium which is depressed temporarily.

(iv) Examples of transverse wave motion: Movement of string of a sitar, waves on the surface of water.

(v) Transverse waves can not be transmitted into liquids and gases.

(5) Longitudinal waves: If the particles of a medium vibrate in the direction of wave motion the wave is called longitudinal.

(i) It travels in the form of compression and rarefaction.

(ii) A compression (c) is a region of the medium in which particles are compressed.

(iii) A rarefaction (R) is a region of the medium in which particles are rarefied.

(iv) Examples sound waves travel through air in the form of longitudinal waves.

(v) These waves can be transmitted through solids, liquids and gases.

10.16 Important Terms

(1) Wavelength :

- (i) It is the length of one wave.
- (ii) Distance travelled by the wave in one time period is known as wavelength.

$$\lambda = \text{Distance between two consecutive crests or troughs.}$$

(2) Frequency : Number of vibrations completed in one second.

(3) Time period : Time period of vibration of particle is defined as the time taken by the particle to complete one vibration about its mean position.

(4) Relation between frequency and time period :

$$\text{Time period} = 1 / \text{Frequency}$$

$$\Rightarrow T = 1/n$$

(5) Relation between velocity, frequency and wavelength : $v = n\lambda$.

10.17 Velocity of Sound (Wave motion)

(1) Speed of transverse wave motion :

- (i) On a stretched string : $v = \sqrt{\frac{T}{m}}$, T = Tension in the string;

m = Linear density of string (mass per unit length).

- (ii) In a solid body : $v = \sqrt{\frac{\eta}{\rho}}$ (η = Modulus of rigidity; ρ = Density of the material.)

(2) Speed of longitudinal wave motion :

- (i) In a solid long bar $v = \sqrt{\frac{Y}{\rho}}$ (Y = Young's modulus; ρ = Density)

- (ii) In a liquid medium $v = \sqrt{\frac{k}{\rho}}$ (k = Bulk modulus)

- (iii) In gases $v = \sqrt{\frac{k}{\rho}}$

10.18 Velocity of Sound in Elastic Medium

Velocity of sound in any medium is

$$v = \sqrt{\frac{E}{\rho}} \quad (E = \text{Elasticity of the medium; } \rho = \text{Density of the medium})$$

$$(1) v_{\text{steel}} > v_{\text{water}} > v_{\text{air}} \Rightarrow 5000 \text{ m/s} > 1500 \text{ m/s} > 330 \text{ m/s}$$

(2) **Newton's formula** : He assumed that propagation of sound is isothermal

$$v_{\text{air}} = \sqrt{\frac{E}{\rho}} = \sqrt{\frac{P}{\rho}} \quad \text{As } K = E_{\theta} = P; E_{\theta} = \text{Isothermal elasticity; } P = \text{Pressure.}$$

By calculation $v_{\text{air}} = 279 \text{ m/sec.}$

However the experimental value of sound in air is 332 m/sec

(3) **Laplace correction** : He modified that propagation of sound in air is adiabatic process.

$$v = \sqrt{\frac{k}{\rho}} = \sqrt{\frac{E_{\phi}}{\rho}} \quad (\text{As } k = E_{\phi} = \gamma P = \text{Adiabatic elasticity})$$

$$v = 331.3 \text{ m/s } (\gamma_{\text{Air}} = 1.41)$$

$$(4) \text{ Effect of density : } v = \sqrt{\frac{\gamma P}{\rho}} \Rightarrow v \propto \frac{1}{\sqrt{\rho}}$$

(5) **Effect of pressure** : Velocity of sound is independent of the pressure (when $T = \text{constant}$)

(6) **Effect of temperature** : $v \propto \sqrt{T(\text{in K})}$

When the temperature change is small then $v_t = v_0 (1 + \alpha t)$

$$\text{Value of } \alpha = 0.608 \frac{\text{m/s}}{^{\circ}\text{C}} = 0.61 \text{ (Approx.)}$$

(7) **Effect of humidity** : With rise in humidity velocity of sound increases.

(8) Sound of any frequency or wavelength travels through a given medium with the same velocity.

(9) Sound of any frequency or wavelength travels through a given medium with the same velocity.

10.19 Reflection of Mechanical

Medium	Longitudinal wave	Transverse wave	Change in direction	Phase change	Time change	Path change
Reflection from rigid end/denser medium	Compression as rarefaction and vice-versa	Crest as crest and Trough as trough	Reversed	π	$\frac{T}{2}$	$\frac{\lambda}{2}$
Reflection from free end/rarer medium	Compression as compression and rarefaction as rarefaction	Crest as trough and trough as crest	No change	Zero	Zero	Zero

10.20 Progressive Wave

- (1) These waves propagate in the forward direction of medium with a finite velocity.
- (2) Energy and momentum are transmitted in the direction of propagation of waves.
- (3) In progressive waves, equal changes in pressure and density occurs at all points of medium.
- (4) Various forms of progressive wave function.

(i) $y = A \sin (\omega t - kx)$ Where $y =$ displacement

$A =$ amplitude

$\omega =$ angular frequency

$n =$ frequency

$k =$ propagation constant

$T =$ time period

$\lambda =$ wave length

$v =$ wave velocity

$t =$ instantaneous time

(ii) $y = A \sin \left(\omega t - \frac{2\pi}{\lambda} x \right)$

$$(iii) y = A \sin 2\pi \left[\frac{t}{T} - \frac{x}{\lambda} \right]$$

$$(iv) y = A \sin \frac{2\pi}{\lambda} (vt - x)$$

$$(v) y = A \sin \omega \left(t - \frac{x}{v} \right)$$

(a) If the sign between t and x terms is negative the wave is propagating along positive X-axis and if the sign is positive then the wave moves in negative X-axis direction.

(b) The Argument of sin or cos function *i.e.* $(\omega t - kx) = \text{Phase}$.

(c) The coefficient of t gives angular frequency

$$\omega = 2\pi n = \frac{2\pi}{T}$$

(d) The coefficient of x gives propagation constant or wave number

$$k = \frac{2\pi}{\lambda} = \frac{\omega}{v}$$

(e) The ratio of coefficient of t to that of x gives wave or phase velocity,

$$i.e. \quad v = \frac{\omega}{k}$$

(f) When a given wave passes from one medium to another its frequency does not change.

(g) From $v = n\lambda \Rightarrow v \propto \lambda \therefore n = \text{constant} \Rightarrow \frac{v_1}{v_2} = \frac{\lambda_1}{\lambda_2}$.

(5) Some terms related to progressive waves

(i) **Wave number** (\ddot{n}): The number of waves present in unit length.

$$(\ddot{n}) = \frac{1}{\lambda}$$

(ii) Propagation constant (k): $k = \frac{\phi}{x}$

$$k = \frac{\omega}{v} = \frac{\text{Angular velocity}}{\text{Wave velocity}} \text{ and } k = \frac{2\pi}{\lambda} = 2\pi\ddot{\lambda}$$

$$(iii) \text{ Wave velocity } (v) : v = \frac{\omega}{k} = n\lambda = \frac{\omega\lambda}{2\pi} = \frac{\lambda}{T}.$$

$$(iv) \text{ Phase and phase difference } \phi(x, t) = \frac{2\pi}{\lambda}(vt - x).$$

$$(v) \text{ Phase difference} = \frac{2\pi}{T} \times \text{Time difference}.$$

$$(vi) \text{ Phase difference} = \frac{2\pi}{\lambda} \times \text{Path difference}$$

$$\Rightarrow \text{Time difference} = \frac{T}{\lambda} \times \text{Path difference}.$$

10.21 Principle of Superposition

$\rightarrow \rightarrow \rightarrow$
If y_1, y_2, y_3, \dots are the displacements at a particular time at a particular position, due to individual waves, then the resultant displacement,

$$\rightarrow \rightarrow \rightarrow \rightarrow$$

$$y = y_1 + y_2 + y_3 + \dots$$

Important applications of superposition principle: (a) Stationary waves, (b) Beats.

10.22 Standing Waves or Stationary Waves

When two sets of progressive wave trains of same type (both longitudinal or both transverse) having the same amplitude and same time period/frequency/wavelength travelling with same speed along the same straight line in opposite directions superimpose, a new set of waves are formed. These are called stationary waves or standing waves.

Characteristics of standing waves :

- (1) The disturbance confined to a particular region
- (2) There is no forward motion of the disturbance beyond this particular region.
- (3) The total energy is twice the energy of each wave.
- (4) Points of zero amplitude are known as nodes.

The distance between two consecutive nodes is $\frac{\lambda}{2}$.

- (5) Points of maximum amplitude is known as antinodes. The distance between two consecutive antinodes is also $\lambda/2$. The distance between a node and adjoining antinode is $\lambda/4$.
- (6) The medium splits up into a number of segments.
- (7) All the particles in one segment vibrate in the same phase. Particles in two consecutive segments differ in phase by 180° .
- (8) Twice during each vibration, all the particles of the medium pass simultaneously through their mean position.

10.23 Comparative Study of Stretched Strings, Open Organ Pipe and Closed Organ Pipe

S. No.	Parameter	Stretched string	Open organ Pipe	Closed organ Pipe
(1)	Fundamental frequency or 1 st harmonic (1 st mode of vibration)	$n_1 = \frac{v}{2l}$	$n_1 = \frac{v}{2l}$	$n_1 = \frac{v}{4l}$
(2)	Frequency of 1 st overtone or 2 nd harmonic (2 nd mode of vibration)	$n_2 = 2n_1$	$n_2 = 2n_1$	Missing
(3)	Frequency of 2 nd overtone or 3 rd harmonic (3 rd mode of vibration)	$n_3 = 3n_1$	$n_3 = 3n_1$	$n_3 = 3n_1$
(4)	Frequency ratio of overtones	2:3:4:...	2:3:4:...	3:5:7:...
(5)	Frequency ratio of harmonics	1:2:3:4:...	1:2:3:4:...	1:3:5:7:...

(6) Nature of waves	Transverse stationary	Longitudinal stationary	Longitudinal stationary
(7) General formula for wavelength	$\lambda = \frac{2L}{n}, n = 1, 2, 3, \dots$	$\lambda = \frac{2L}{n}, n = 1, 2, 3, \dots$	$\lambda = \frac{4L}{(2n-1)}$
(8) Position of nodes	$x = 0, \frac{L}{n}, \frac{2L}{n}, \frac{3L}{n}, \dots$	$x = \frac{L}{2n}, \frac{3L}{2n}, \frac{5L}{2n}, \dots, \frac{(2n-1)L}{2n}$	$x = 0, \frac{2L}{(2n-1)}, \frac{4L}{(2n-1)}, \frac{6L}{(2n-1)}, \dots, \frac{2nL}{(2n-1)}$
(9) Position of antinodes	$x = \frac{L}{2n}, \frac{3L}{2n}, \frac{5L}{2n}, \dots, \frac{(2n-1)L}{2n}$	$x = \frac{L}{n}, \frac{2L}{n}, \frac{3L}{n}, \dots$	$x = \frac{L}{2n-1}, \frac{3L}{2n-1}, \frac{5L}{2n-1}, \dots, L$

- (i) Harmonics are the notes/sounds of frequency equal to or an integral multiple of fundamental frequency (n).
- (ii) Overtones are the notes/sounds of frequency twice/thrice/ four times the fundamental frequency (n).
- (iii) In organ pipe an antinode is not formed exactly at the open end rather it is formed a little distance away from the open end outside it. The distance of antinode from the open end of the pipe is $= 0.6r$ (where r is radius of organ pipe). This is known as end correction.

10.24 Vibration of a String

General formula of frequency $n_p = \frac{p}{2L} \sqrt{\frac{T}{m}}$

L = Length of string, T = Tension in the string

m = Mass per unit length (linear density), p = mode of vibration

(1) The string will be in resonance with the given body if any of its natural frequencies coincides with the body.

(2) If M is the mass of the string of length L , $m = \frac{M}{L}$.

$$\text{So } n = \frac{1}{2Lr} \sqrt{\frac{T}{\pi\rho}} \quad (r = \text{Radius}, \rho = \text{Density})$$

10.25 Beats

When two sound waves of slightly different frequencies, travelling in a medium along the same direction, superimpose on each other, the intensity of the resultant sound at a particular position rises and falls regularly with time. This phenomenon is called beats.

- (1) **Beat period** : The time interval between two successive beats (*i.e.* two successive maxima of sound) is called beat period.
- (2) **Beat frequency** : The number of beats produced per second is called beat frequency.
- (3) **Persistence of hearing** : The impression of sound heard by our ears persist in our mind for $1/10^{\text{th}}$ of a second.

So for the formation of distinct beats, frequencies of two sources of sound should be nearly equal (difference of frequencies less than 10)

- (4) **Equation of beats** : If two waves of equal amplitudes ' a ' and slightly different frequencies n_1 and n_2 travelling in a medium in the same direction then equation of beats is given by

$y = A \sin \pi (n_1 - n_2)t$ where $A = 2a \cos \pi (n_1 - n_2)t =$ Amplitude of resultant wave.

Amplitude of resultant wave.

- (5) **Beat frequency** : $n = n_1 - n_2$.

- (6) **Beat period**: $\frac{1}{\text{Beat frequency}} = \frac{1}{n_1 - n_2}$

10.26 Doppler Effect

Whenever there is a relative motion between a source of sound and the listener, the apparent frequency of sound heard by the listener is different from the actual frequency of sound emitted by the source.

$$\text{Apparent frequency } n' = \frac{[(v + v_m) - v_L]n}{[(v + v_m) - v_s]}$$

Here $n =$ Actual frequency; $v_L =$ Velocity of listener; $v_s =$ Velocity of source

$v_m =$ Velocity of medium and $v =$ Velocity of sound wave

Sign convention: All velocities along the direction S to L are taken as positive and all velocities along the direction L to S are taken as negative. If the

medium is stationary $v_m = 0$ then $n' = \left(\frac{v - v_L}{v - v_s} \right) n$.

- (1) No Doppler effect takes place ($n' = n$) when relative motion between source and listener is zero.
- (2) Source and listener moves at right angle to the direction of wave propagation. ($n' = n$)
 - (i) If the velocity of source and listener is equal to or greater than the sound velocity then Doppler effect is not observed.
 - (ii) Doppler effect does not say about intensity of sound.
 - (iii) Doppler effect in sound is asymmetric but in light it is symmetric.

QUESTIONS

ONE MARK QUESTIONS

1. How is the time period effected, if the amplitude of a simple pendulum is increased?
2. Define force constant of a spring.
3. At what distance from the mean position, is the kinetic energy in simple harmonic oscillator equal to potential energy ?
4. How is the frequency of oscillation related with the frequency of change in the K.E. and P.E. of the body in S.H.M.?
5. What is the frequency of total energy of a particle in S.H.M. ?
6. How is the length of seconds pendulum related with acceleration due to gravity of any planet ?
7. If the bob of a simple pendulum is made to oscillate in some fluid of density greater than the density of air (density of the bob > density of the fluid), then time period of the pendulum increased or decrease.
8. How is the time period of the pendulum effected when pendulum is taken to hills or in mines ?
9. A transverse wave travels along x-axis. The particles of the medium must move in which direction ?
10. Define angular frequency. Give its S.I. unit.

11. Sound waves from a point source are propagating in all directions. What will be the ratio of amplitudes at distances of x meter and y meter from the source ?
12. Does the direction of acceleration at various points during the oscillation of a simple pendulum remain towards mean position ?
13. What is the time period for the function $f(t) = \sin \omega t + \cos \omega t$ may represent the simple harmonic motion ?
14. When is the swinging of simple pendulum considered approximately SHM ?
15. Can the motion of an artificial satellite around the earth be taken as SHM?
16. What is the phase relationship between displacement, velocity and acceleration in SHM ?
17. What forces keep the simple pendulum in motion ?
18. How will the time period of a simple pendulum change when its length is doubled ?
19. What is a harmonic wave function ?
20. If the motion of revolving particle is periodic in nature, give the nature of motion or projection of the revolving particle along the diameter.
21. In a forced oscillation of a particle, the amplitude is maximum for a frequency w_1 of the force, while the energy is maximum for a frequency w_2 of the force. What is the relation between w_1 and w_2 ?
22. Which property of the medium are responsible for propagation of waves through it ?
23. What is the nature of the thermal change in air, when a sound wave propagates through it ?
24. Why does sound travel faster in iron than in water or air ?
25. When will the motion of a simple pendulum be simple harmonic ?
26. A simple harmonic motion of acceleration ' a ' and displacement ' x ' is represented by $a + 4\pi^2x = 0$. What is the time period of S.H.M ?
27. What is the main difference between forced oscillations and resonance ?
28. Define amplitude of S.H.M.

29. What is the condition to be satisfied by a mathematical relation between time and displacement to describe a periodic motion ?
30. Why the pitch of an organ pipe on a hot summer day is higher ?
31. Under what conditions does a sudden phase reversal of waves on reflection takes place ?
32. The speed of sound does not depend upon its frequency. Give an example in support of this statement.
33. If an explosion takes place at the bottom of lake or sea, will the shock waves in water be longitudinal or transverse ?
34. Frequency is the most fundamental property of wave, why ?
35. How do wave velocity and particle velocity differ from each other ?
36. If any liquid of density higher than the density of water is used in a resonance tube, how will the frequency change ?
37. Under what condition, the Doppler effect will not be observed, if the source of sound moves towards the listener ?
38. What physical change occurs when a source of sound moves and the listener is stationary ?
39. What physical change occurs when a source of sound is stationary and the listener moves ?
40. If two sound waves of frequencies 480 Hz and 536 Hz superpose, will they produce beats? Would you hear the beats ?
41. Define non dissipative medium.

2 MARKS QUESTIONS

42. Which of the following condition is not sufficient for simple harmonic motion and why ?
 - (i) acceleration and displacement
 - (ii) restoring force and displacement
43. The formula for time period T for a loaded spring, $T = 2\pi\sqrt{\frac{\text{displacement}}{\text{acceleration}}}$
Does the time period depend on length of the spring ?

44. Water in a U-tube executes S.H.M. Will the time period for mercury filled up to the same height in the tube be lesser or greater than that in case of water ?
45. There are two springs, one delicate and another hard or stout one. For which spring, the frequency of the oscillator will be more ?
46. Time period of a particle in S.H.M. depends on the force constant K and mass m of the particle $T = 2\pi\sqrt{\frac{m}{k}}$. A simple pendulum for small angular displacement executes S.H.M. approximately. Why then is the time period of a pendulum independent of the mass of the pendulum ?
47. What is the frequency of oscillation of a simple pendulum mounted in a cabin that is falling freely ?
48. The maximum acceleration of simple harmonic oscillator is A_0 . While the maximum velocity is v_0 , calculate amplitude of motion.
49. The velocity of sound in a tube containing air at 27°C and pressure of 76 cm of Hg is 330 ms^{-1} . What will be its velocity, when pressure is increased to 152 cm of mercury and temperature is kept constant ?
50. Even after the breakup of one prong of tuning fork it produces a sound of same frequency, then what is the use of having a tuning fork with two prongs ?
51. Why is the sonometer box hollow and provided with holes ?
52. The displacement of particle in S.H.M. may be given by $y = a \sin(\omega t + \phi)$ show that if the time t is increased by $2\pi/\omega$, the value of y remains the same.
53. The length of simple pendulum executing SHM is increased by 21%. By what % time period of pendulum increase ?
54. Define wave number and angular wave number and give their S.I. units.
55. Why does the sound travel faster in humid air ?
56. Use the formula $v = \sqrt{\frac{\gamma p}{\rho}}$ to explain, why the speed of sound in air
- (a) is independent of pressure
- (b) increase with temperature

57. Differentiate between closed pipe and open pipe at both ends of same length for frequency of fundamental note and harmonics.
58. Bats can ascertain distances, directions; nature and size of the obstacle without any eyes, explain how ?
59. In a sound wave, a displacement node is a pressure antinode and vice-versa. Explain, why ?
60. How does the frequency of a tuning fork change, when the temperature is increased ?
61. Explain, why can we not hear an echo in a small room ?
62. What do you mean by reverberation? What is reverberation time ?

3 MARKS QUESTIONS

63. Show that for a particle in linear simple harmonic motion, the acceleration is directly proportional to its displacement of the given instant.
64. Show that for a particle in linear simple harmonic motion, the average kinetic energy over a period of oscillation, equals the average potential energy over the same period.
65. Deduce an expression for the velocity of a particle executing S.H.M. when is the particle velocity (i) Maximum (ii) minimum?
66. Draw (a) displacement time graph of a particle executing SHM with phase angle ϕ equal to zero (b) velocity time graph and (c) acceleration time graph of the particle.
67. Show that a linear combination of sine and cosine function like $x(t) = a \sin \omega t + b \cos \omega t$ represents a simple harmonic. Also, determine its amplitude and phase constant.
68. Show that in a S.H.M. the phase difference between displacement and velocity is $\pi/2$, and between displacement and acceleration is π .
69. Derive an expression for the time period of the horizontal oscillations of a massless loaded spring.
70. Show that for small oscillations the motion of a simple pendulum is simple harmonic. Derive an expression for its time period.
71. Distinguish with an illustration among free, forced and resonant oscillations.

72. In reference to a wave motion, define the terms
- (i) amplitude
 - (ii) time period
 - (iii) frequency
 - (iv) angular frequency
 - (v) wave length and wave number.
73. What do you understand by phase of a wave? How does the phase change with time and position.
74. At what time from mean position of a body executive S.H.M. kinetic energy and potential energy will be equal?

LONG ANSWER QUESTIONS

75. Derive expressions for the kinetic and potential energies of a simple harmonic oscillator. Hence show that the total energy is conserved in S.H.M. in which positions of the oscillator, is the energy wholly kinetic or wholly potential ?
76. One end of a U-tube containing mercury is connected to a suction pump and the other end is connected to the atmosphere. A small pressure difference is maintained between the two columns. Show that when the suction pump is removed, the liquid in the U-tube executes S.H.M.
77. Discuss the Newton's formula for velocity of sound in air. What correction was applied to it by Laplace and why ?
78. What are standing waves? Derive an expression for the standing waves. Also define the terms node and antinode and obtain their positions.
79. Discuss the formation of harmonics in a stretched string. Show that in case of a stretched string the first four harmonics are in the ratio 1:2:3:4.
80. Give the differences between progressive and stationary waves.
81. If the pitch of the sound of a source appears to drop by 10% to a moving person, then determine the velocity of motion of the person. Velocity of sound = 30 ms^{-1} .
82. Give a qualitative discussion of the different modes of vibration of an open organ pipe.
83. Describe the various modes of vibrations of a closed organ pipe.

84. What are beats? How are they produced? Briefly discuss one application for this phenomenon.
85. Show that the speed of sound in air increases by 61 cms^{-1} for every 1°C rise of temperature.

NUMERICALS

86. The time period of a body executing S.H.M is 1s. After how much time will its displacement be $\frac{1}{\sqrt{2}}$ of its amplitude.
87. A particle is moving with SHM in a straight line. When the distance of the particle from the equilibrium position has values x_1 and x_2 , the corresponding value of velocities are u_1 and u_2 . Show that the time period of oscillation is given by

$$t = 2\pi \left[\frac{\frac{x_2^2 - x_1^2}{2} - \frac{u_1^2 - u_2^2}{2}}{2} \right]^{1/2}$$

88. Find the period of vibrating particle (SHM), which has acceleration of 45 cm s^{-2} , when displacement from mean position is 5 cm.
89. A 40 gm mass produces an extension of 4 cm in a vertical spring. A mass of 200 gm is suspended at its bottom and left pulling down. Calculate the frequency of its vibration.
90. The acceleration due to gravity on the surface of the moon is 1.7 ms^{-2} . What is the time period of a simple pendulum on the moon, if its time period on the earth is 3.5 s? [$g = 9.8 \text{ ms}^{-2}$]
91. A particle executes simple harmonic motion of amplitude A.
- (i) At what distance from the mean position is its kinetic energy equal to its potential energy?
 - (ii) At what points is its speed half the maximum speed?
92. A set of 24 tuning forks is arranged so that each gives 4 beats per second with the previous one and the last sounds the octave of first. Find frequency of 1st and last tuning forks.
93. The vertical motion of a huge piston in a machine is approximately S.H.M. with a frequency of 0.5 s^{-1} . A block of 10kg is placed on the piston. What is the maximum amplitude of the piston's S.H.M. for the block and piston to remain together?

94. At what temperature will the speed of sound be double its value at 273°K ?
95. A spring balance has a scale that reads from 0 to 50 kg. The length of the scale is 20 cm. A body suspended from this spring, when displaced and released, oscillates with a period of 0.60 s. What is the weight of the body ?
96. If the pitch of the sound of a source appears to drop by 10% to a moving person, then determine the velocity of motion of the person. Velocity of sound = 330 ms^{-1} .
97. A body of mass m suspended from a spring executes SHM. Calculate ratio of K.E. and P.E. of body when it is at a displacement half of its amplitude from mean position.
98. A string of mass 2.5 kg is under a tension of 200N. The length of the stretched string is 20m. If a transverse jerk is struck at one end of the string, how long does the disturbance take to reach the other end ?
99. Which of the following function of time represent (a) periodic and (b) non-periodic motion? Give the period for each case of periodic motion. [w is any positive constant].
- (i) $\sin \omega t + \cos \omega t$
- (ii) $\sin \omega t + \sin 2\omega t + \sin 4 \omega t$
- (iii) $e^{-\omega t}$
- (iv) $\log (\omega t)$
100. The equation of a plane progressive wave is given by the equation $y = 10 \sin 2\pi (t - 0.005x)$ where y and x are in cm and t in seconds. Calculate the amplitude, frequency, wave length and velocity of the wave.
101. A tuning fork arrangement (pair) produces 4 beats s^{-1} with one fork of frequency 288 cps. A little wax is placed on the unknown fork and it then produces 2 beats s^{-1} . What is the frequency of the unknown fork ?
102. A pipe 20 cm long is closed at one end, which harmonic mode of the pipe is resonantly excited by a 430 Hz source? Will this same source can be in resonance with the pipe, if both ends are open? Speed of sound = 340 ms^{-1} .
103. The length of a wire between the two ends of a sonometer is 105 cm. Where should the two bridges be placed so that the fundamental frequencies of the three segments are in the ratio of 1 : 3 : 15 ?

104. The transverse displacement of a string (clamped at its two ends) is given by

$$y(x, t) = 0.06 \sin \frac{2\pi}{3} \cos 120 \omega t.$$

where x, y are in m and t is in s. The length of the string is 1.5 m and its mass is 3.0×10^{-2} kg. Answer the following.

- Does the function represent a travelling or a stationary wave?
 - Interpret the wave as a superposition of two waves travelling in opposite directions. What are the wavelength frequency and speed of propagation of each wave ?
 - Determine the tension in the string.
105. A wire stretched between two rigid supports vibrates in its fundamental mode with a frequency 45 Hz. The mass of the wire is 3.5×10^{-2} kg and its linear density is 4.0×10^{-2} kg m⁻¹. What is (a) the speed of transverse wave on the string and (b) the tension in the string ?
106. A steel rod 100 cm long is clamped at its middle. The fundamental frequency of longitudinal vibrations of the rod as given to be 2.53 kHz. What is the speed of sound in steel ?
107. A progressive wave of frequency 500 Hz is travelling with velocity 360 m/s. How far apart are two points 60° out of phase ?
108. An observer moves towards a stationary source of sound with a velocity one fifth of velocity of sound. What is the % increase in apparent frequency ?

ASSERTION - REASON BASED QUESTIONS

Direction:- Read the assertion and reason carefully to mark the correct option out of the options given below :

- If both assertion and reason are true and the reason is the correct explanation of the assertion.
- If both assertion and reason are true but reason is not the correct explanation of the assertion.
- If assertion is true but reason is false.
- If the assertion and reason both are false.
- If assertion is false but reason is true.

1. Assertion : All oscillatory motions are necessarily periodic motion but all periodic motions are not oscillatory.

Reason: Simple pendulum is an example of oscillatory motion.

2. Assertion: Simple harmonic motion is a uniform motion.
Reason: Simple harmonic motion is the projection of uniform circular motion.
3. Assertion: Acceleration is proportional to the displacement. This condition is not sufficient for motion in simple harmonic.
Reason: In simple harmonic motion direction of displacement is also considered.
4. Assertion: Sine and cosine functions are periodic functions.
Reason: Sinusoidal functions repeats it values after a definite interval of time.
5. Assertion: The graph between velocity and displacement for a harmonic oscillator is a parabola.
Reason: Velocity does not change uniformly with displacement in harmonic motion.
6. Assertion: When a simple pendulum is made to oscillate on the surface of moon, its time period Increases.
Reason: Moon is much smaller as compared to earth.
7. Assertion: Resonance is special case of forced vibration in which the natural frequency of vibration of the body is the same as the impressed frequency of external periodic force and the amplitude of forced vibration is maximum.
Reason: The amplitude of forced vibrations of a bod increases with an increase in the frequency of the externally impressed periodic force.
8. Assertion: The graph of total energy of a particle in SHM w.r.t. position is a straight line with zero slope.
Reason: Total energy of particle in SHM remains constant throughout its motion.
9. Assertion: The percentage change in time period is 1.5%, if the length of simple pendulum increases by 3%.
Reason: Time period is directly proportional to length of pendulum.
10. Assertion: The frequency of a second pendulum in an elevator moving up with an acceleration half the acceleration due to gravity is 0.612 Hz .
Reason: The frequency of a second pendulum does not depend upon acceleration due to gravity.
11. Assertion: Damped oscillation indicates loss of energy.
Reason: The energy loss in damped oscillation may be due to friction, air resistance etc.

HINTS AND ANSWERS

1. (b) Both assertion and reason are correct but reason is not the correct explanation of assertion.
2. (e) simple harmonic motion, $v = \omega\sqrt{a^2 - y^2}$ as y changes, velocity v will also change. So simple harmonic motion is not uniform motion. But simple harmonic motion may be defined as the projection of uniform circular motion along one of the diameter of the circle.
3. (a) In SHM, the acceleration is always in a direction opposite to that of the displacement i.e., proportional to $(-y)$.
4. (a) A periodic function is one whose value repeats after a definite interval of time. $\sin\theta$ and $\cos\theta$ are periodic functions because they repeat themselves after 2π interval of time.

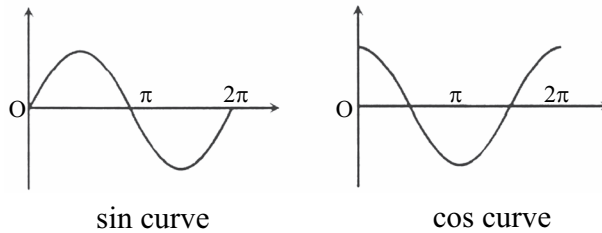

It is also true that moon is smaller than the earth, but this statement is not explaining the assertion.

5. (e) In SHM, $v = \omega\sqrt{a^2 - y^2}$ or $v^2 = \omega^2(a^2 - y^2)$.
Dividing both sides by $\omega^2 a^2$, $\frac{v^2}{\omega^2 a^2} + \frac{y^2}{a^2} = 1$. This is the equation of an ellipse. Hence the graph between v and y is an ellipse not a parabola.
6. (b) $T = 2\pi\sqrt{\frac{l}{g}}$. On moon, g is much smaller compared to g on earth.
Therefore, T increases.
7. (c) Amplitude of oscillation for a forced, damped oscillator is

$$A = \frac{F_0 / m}{\sqrt{(\omega^2 - \omega_0^2)^2 + (b\omega / m)^2}}$$
, where b is constant related to the strength of the resistive force, $\omega_0 = \sqrt{k/m}$ is natural frequency of undamped oscillator ($b = 0$).

When the Frequency of driving force $\omega \approx \omega_0$, then amplitude A is very larger.

For $\omega < \omega_0$ or $\omega > \omega_0$, the amplitude decrease.

8. (a) The total energy of S.H.M. = Kinetic energy of particle + potential energy of particle.

The variation of total energy of the particle in SHM with time is shown in a graph.

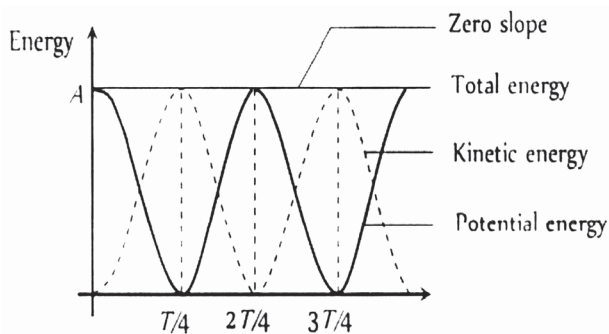

9. (c) Time period of simple pendulum of length is,

$$T = 2\pi\sqrt{\frac{l}{g}} \Rightarrow T \propto \sqrt{l} \Rightarrow \sqrt{\frac{\Delta T}{T}} = \frac{1}{2} \frac{\Delta l}{l}$$

$$\therefore \frac{\Delta T}{T} = \frac{1}{2} \times 3 = 1.5\%$$

10. (c) Frequency of second pendulum $n = (1/2)\text{s}^{-1}$. When elevator is moving upwards with acceleration $g/2$, the effective acceleration due to gravity is

$$g = g + a = g + g/2 = 3g/2.$$

$$\text{As } n = \frac{1}{2\pi}\sqrt{\frac{g}{l}} \text{ so } n^2 \propto g.$$

$$\therefore \frac{n_1^2}{n_2^2} = \frac{g_1}{g} = \frac{3g/2}{g} = \frac{3}{2} \text{ or } \frac{n_1}{n} = \sqrt{\frac{3}{2}} = 1.225$$

$$\text{or, } n_1 = 1.225n = 1.225 \times (1/2) = 0.612\text{s}^{-1}.$$

11. (b) Energy of damped oscillator at any instant t is given by

$$E = E_0 e^{-bt/m} \text{ [where } E_0 = \frac{1}{2} kx^2 = \text{maximum energy]}$$

Due to damping forces the amplitude of oscillator will go on decreasing with time whose energy is expressed by above equation.

CASE STUDY BASED QUESTIONS

Simple Pendulum

An ideal simple pendulum consists of a heavy point mass body (bob) suspended by a weightless, inextensible and perfectly flexible string from a rigid support about which it is free to oscillate.

But in reality neither point mass nor weightless string exist, so we can never construct a simple pendulum strictly according to the definition.

Suppose simple pendulum of length l is displaced through a small angle θ from its mean (vertical) position. Consider m as the mass of the bob is m and linear displacement from mean position is x .

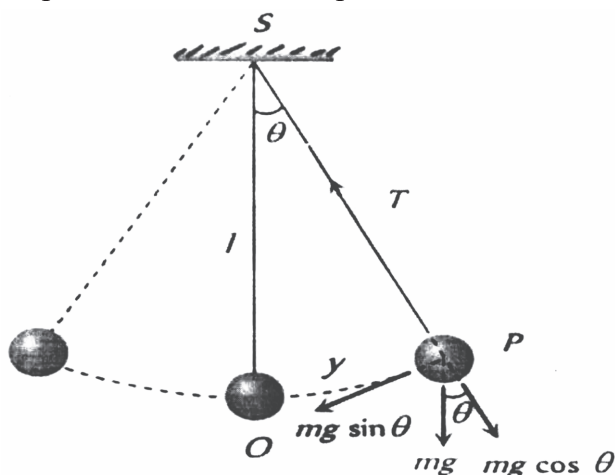

Answer the following questions :-

- The period of a simple pendulum is doubled, when
 - Its length is doubled
 - The mass of the bob is doubled
 - Its length is made four times
 - The mass of the bob and the length of the pendulum are doubled
- The period of oscillation of a simple pendulum of constant length at earth surface is T . Its period inside a mine is
 - Greater than T
 - Less than T
 - Equal to T
 - Cannot be compared

3. A pendulum suspended from the ceiling of a train has a period T , when the train is at rest. When the train is accelerating with a uniform acceleration a , the period of oscillation will
- (a) Increase (b) Decrease
(c) Remain unaffected (d) Become infinite
4. Which of the following statements is not true? In the case of a simple pendulum for small amplitudes the period of oscillation is
- (a) Directly proportional to square root of the length of the pendulum
(b) Inversely proportional to the square root of the acceleration due to gravity
(c) Dependent on the mass, size and material of the bob
(d) Independent of the amplitude
5. The time period of a second's pendulum is 2 sec. The spherical bob which is empty from inside has a mass of 50 gm. This is now replaced by another solid bob of same radius but having different mass of 100 gm. The new time period will be
- (a) 4 sec (b) 1 sec (c) 2sec (d) 8sec

HINTS AND ANSWERS

1. (c) $T = 2\pi\sqrt{\frac{l}{g}} \Rightarrow T \propto \sqrt{l}$
2. (a) Inside the mine g decreases
Hence from $T = 2\pi\sqrt{\frac{l}{g}}$; T increases
3. (b) Initially time period was $T = 2\pi\sqrt{\frac{l}{g}}$.
When train acceleration, the effective value of g becomes $\sqrt{(g^2 + a^2)}$ which is greater than g .
- Hence, new time period, becomes less than the initial time period.
4. (c)
5. (c) $T = 2\pi\sqrt{\frac{l}{g}}$ (independent of mass)

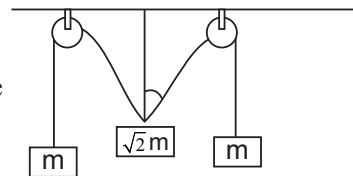

WAVES

ASSERTION - REASON BASED QUESTIONS

Direction:- Read the assertion and reason carefully to mark the correct option out of the options given below :

- (a) If both assertion and reason are true and the reason is the correct explanation of the assertion.
- (b) If both assertion and reason are true but reason is not the correct explanation of the assertion.
- (c) If assertion is true but reason is false.
- (d) If the assertion and reason both are false.
- (e) If assertion is false but reason is true.

1. Assertion : Two persons on the surface of moon cannot talk to each other.
Reason: There is no atmosphere on moon.
2. Assertion: Transverse waves are not produced in liquids and gases.
Reason: Light waves are transverse waves.
3. Assertion: Sound waves cannot propagate through vacuum but light waves can.
Reason: Sound waves cannot be polarised but light waves can be polarised.
4. Assertion: The velocity of sound increases with increase in humidity.
Reason: Velocity of sound does not depend upon the medium.
5. Assertion: Ocean waves hitting a beach are always found to be nearly normal to the shore.
Reason: Ocean waves are longitudinal waves.
6. Assertion: Compression and rarefaction involve changes in density and pressure.
Reason: When particles are compressed, density of medium increases and when they are rarefied, density of medium decreases.
7. Assertion: Transverse waves travel through air in an organ pipe.
Reason: Air possesses only volume elasticity.
8. Assertion: Sound would travel faster on a hot summer day than on a cold winter day.
Reason: Velocity of sound is directly proportional to the square of its absolute temperature.

9. Assertion: The basic of Laplace correction was that, exchange of heat between the region of compression and rarefaction in air is not possible.
Reason: Air is a bad conductor of heat and velocity of sound in air is large.
10. Assertion: Particle velocity and wave velocity both are independent of time.
Reason: For the propagation of wave motion, the medium must have the properties of elasticity and inertia.
11. Assertion: When we start filling an empty bucket with water, the pitch of sound produced goes on decreasing.
Reason: The frequency of man voice is usually higher than that of woman.
12. Assertion: A tuning fork is made of an alloy of steel, nickel and chromium.
Reason: The alloy of steel, nickel and chromium is called elinvar.

HINTS AND ANSWERS

- (a) Sound waves require material medium to travel. As there is no atmosphere (vacuum) on the surface of moon, therefore the sound waves cannot reach from one person to another.
- (b) Transverse waves travel in the form of crests and troughs involving change in shape of the medium. As liquids and gases do not possess the elasticity of shape, therefore, transverse waves cannot be produced in liquid and gases. Also, light wave is one example of transverse wave.
- (b) Sound waves cannot propagate through vacuum because sound waves are mechanical waves. Light waves can propagate through vacuum because light waves are electromagnetic waves. Since sound waves are longitudinal waves, the particles move in the direction of propagation, therefore these waves cannot be polarised.
- (c) Velocity of sound in gas medium is $v = \sqrt{\frac{K}{\rho}} = \sqrt{\frac{\gamma P}{\rho}}$ is ratio of its principal heat capacities (C_p / C_v). For moist air ρ is less than that for dry air and γ is slightly greater.
 \therefore velocity of sound increases with increase in humidity.
- (c) Ocean waves are transverse waves travelling in concentric circles of ever-increasing radius. When they hit the shore, their radius of curvature is so large that they can be treated as plane waves. Hence, they hit the shore nearly normal to the shore.

6. (a) A compression is a region of medium in which particles come closer i.e., distance between the particles becomes less than the normal distance between them. Thus, there is a temporary decrease in volume and a consequent increase in density of medium. Similarly in rarefaction, particles get farther apart and a consequent decrease in density.
7. (e) Since transverse wave can propagate through medium which possess elasticity of shape. Air possesses only volume elasticity therefore transverse wave cannot propagate through air.
8. (c) The velocity of sound in a gas is directly proportional to the square root of its absolute temperature $\left(\text{as } v = \sqrt{\frac{\gamma RT}{M}} \right)$. Since temperature of a hot day is more than cold winter day, therefore sound would travel faster on a hot summer day than on a cold winter day.
9. (c) According to Laplace, the changes in pressure and volume of a gas, when sound waves propagated through it, are not isothermal, but adiabatic. A gas is a bad conductor of heat. It does not allow the free exchange of heat between compressed layer, rarefied layer and surrounding.
10. (e) The velocity of every oscillating particle of the medium is different of its different positions in one oscillation but the velocity of wave motion is always constant i.e., particle velocity varies with respect to time, while the wave velocity is independent of time.
Also for wave propagation medium must have the properties of elasticity and inertia.
11. (d) A bucket can be treated as a pipe closed at one end. The frequency of the note produced $f = \frac{v}{4L}$, here L equal to depth of water level from the open end. As the bucket is filled with water L decreases, hence frequency increases. Therefore, frequency or pitch of sound produced goes on increasing. Also, the frequency of woman voice is usually higher than that of man.
12. (b) A tuning fork is made of a material for which elasticity does not change. Since the alloy of nickel, steel and chromium (elinvar) has constant elasticity, therefore it is used for the preparation of tuning fork.

CASE STUDY BASED QUESTIONS

- I. Doppler's Effect or Doppler Shift** is the change in frequency of a wave in relation to an observer who is moving relative to the wave source. It is named after the Austrian physicist Christian Doppler, who described the phenomenon in 1842.

Whenever there is a relative motion between a source of sound and the observer (listener), the frequency of sound heard by the observer is different from the actual frequency of sound emitted by the source. The frequency observed by the observer is called the apparent frequency. It may be less than or greater than the actual frequency emitted by the sound source. The difference depends on the relative motion between the source and observer.

A common example of Doppler shift is the change of pitch heard when a vehicle sounding a horn approaches and recedes from an observer. Compared to the emitted frequency, the received frequency is higher during the approach, identical at the instant of passing by, and lower during the recession.

Answer the following questions :-

- Doppler shift in frequency does not depend upon
 - The frequency of the wave produced
 - The velocity of the source
 - The velocity of the observer
 - Distance from the source to the listener
- A source of sound of frequency 450 cycles/sec is moving towards a stationary observer with 34 m/sec speed. If the speed of sound is 340 m/sec, then the apparent frequency will be
 - 410 cycles/sec
 - 500 cycles/sec
 - 550 cycles/sec
 - 450 cycles/sec
- The wavelength is 120 cm when the source is stationary. If the source is moving with relative velocity of 60 m/sec towards the observer, then the wavelength of the sound wave reaching to the observer will be (velocity of sound = 330 m/s)
 - 98 cm
 - 140 cm
 - 120 cm
 - 144 cm
- The frequency of a whistle of an engine is 600 cycles/sec is moving with the speed of 30 m/sec towards an observer. The apparent frequency will be (velocity of sound = 330 m/s)
 - 600 cps
 - 660 cps
 - 990 cps
 - 330 cps

5. A source of sound emits waves with frequency f Hz and speed V m/sec. Two observers move away from this source in opposite directions each with a speed $0.2 V$ relative to the source. The ratio of frequencies heard by the two observers will be

(a) 3 : 2 (b) 2 : 3 (c) 1 : 1 (d) 4 : 10

II. Standing Wave in a Organ Pipe

Organ pipes are the musical instrument which are used for producing musical sound by blowing air into the pipe. Longitudinal stationary waves are Formed on account of superimposition of incident and reflected longitudinal waves.

Equation of standing wave $y = 2a \cos \frac{2\pi vt}{\lambda} \sin \frac{2\pi x}{\lambda}$

Frequency or vibration $n = \frac{v}{\lambda}$

Different mode of vibration in organ pipe

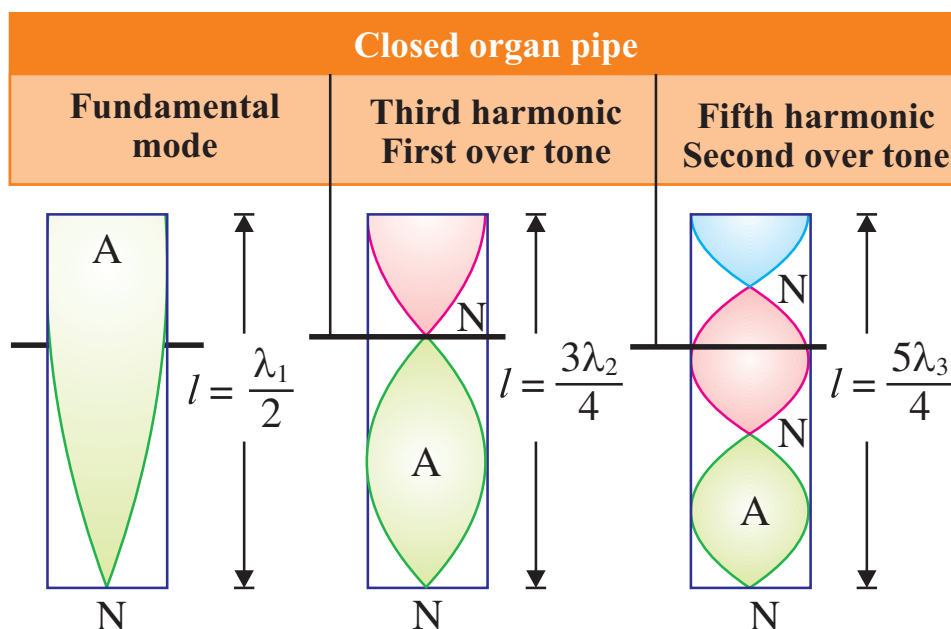

Answer the following questions :-

1. A tube closed at one end and containing air is excited. It produces the fundamental note of frequency 512 Hz. If the same tube is open at both the ends the fundamental frequency that can be produced is
- (a) 1024 Hz (b) 512 Hz (c) 256 Hz (d) 128 Hz

2. A closed pipe and an open pipe have their first overtones identical in frequency. Their lengths are in the ratio
 (a) 1 : 2 (b) 2 : 3 (c) 3 : 4 (d) 4 : 5
3. The first overtone in a closed pipe has a frequency
 (a) Same as the fundamental frequency of an open tube of same length
 (b) Twice the fundamental frequency of an open tube of same length
 (c) Same as that of the first overtone of an open tube of same length
 (d) None of the above
4. An empty vessel is partially filled with water, then the frequency of vibration of air column in the vessel
 (a) Remains same (b) Decreases
 (c) Increases (d) First increases then decreases
5. It is desired to increase the fundamental resonance frequency in a tube which is closed at one end. This can be achieved by
 (a) Replacing the air in the tube by hydrogen gas
 (b) Increasing the length of the tube
 (c) Decreasing the length of the tube

HINTS AND ANSWERS

- I. 1. (d)
2. (b) $n' = n \left(\frac{v}{v - v_o} \right) = 450 \left(\frac{340}{340 - 34} \right) = 500 \text{ cycles / sec.}$
3. (a) $n' = n \left(\frac{v}{v - v_s} \right) \Rightarrow \lambda' = \lambda \left(\frac{v - v_s}{v} \right)$
 $\Rightarrow \lambda' = 120 \left(\frac{330 - 60}{330} \right) = 98 \text{ cm.}$
4. (b) $n' = n \left(\frac{v}{v - v_s} \right) = 600 \left(\frac{330}{300} \right) = 660 \text{ cps.}$
5. (c) Both listeners, hears the same frequencies.

II. 1. (a) Fundamental frequency of open pipe is double that of the closed pipe.

2. (c) If is given that

First over tone of closed pipe = First over tone of open pipe

$$\Rightarrow 3\left(\frac{v}{4l_1}\right) = 2\left(\frac{v}{2l_2}\right);$$

where l_1 and l_2 are the lengths of closed and open organ pipes hence

$$\frac{l_1}{l_2} = \frac{3}{4}$$

3. (d) First overtone for closed pipe = $\frac{3v}{4l}$
 Fundamental frequency for open pipe = $\frac{v}{2l}$
 First overtone for open pipe = $\frac{2v}{2l}$.

4. (c) For closed pipe in general $n = \frac{v}{4l}(2N-1) \Rightarrow n \propto \frac{1}{l}$
 i.e. if length of air column decreases frequency increases.

5.

(a,c,d) Fundamental frequency for closed pipe $n = \frac{v}{4l}$

$$\text{where } v = \sqrt{\frac{\gamma RT}{M}} \Rightarrow v \propto \frac{1}{\sqrt{M}}$$

$$\therefore M_{H_2} < M_{air} \Rightarrow v_{H_2} > v_{air}$$

Hence, fundamental frequency with H will be more as compared to air. So option (a) is correct.

Aslo $n \propto \frac{1}{l}$, hence if l decrease n increases so option (c) is correct.

It is well known that $(n) = 2(n)$ hence option (d) is correct.

SOLUTIONS

ANSWERS OF ONE MARK QUESTIONS

1. No effect on time period when amplitude of pendulum is increased or decreased.
2. The spring constant of a spring is the change in the force it exerts, divided by the change in deflection of the spring. ($K = f/x$)
3. At $x = a/\sqrt{2}$., $KE = PE = \frac{1}{4}m\omega^2 a^2$
4. P.E. or K.E. completes two vibrations in a time during which S.H.M. completes one vibration or the frequency of R.E. or K.E is double than that of S.H.M.
5. The frequency of total energy of particle is S.H.M. is zero because it remains constant.
6. Length of the seconds pendulum proportional to (acceleration due to gravity)
7. Increased
8. As $T \propto \frac{1}{\sqrt{g}}$, T will increase.
9. In the y - z plane or in plane perpendicular to x -axis.
10. It is the angle covered per unit time or it is the quantity obtained by multiplying frequency by a factor of 2π .
 $\omega = 2\pi n$, S.I. unit is rad s^{-1} .
11. Intensity = amplitude² $\propto \frac{1}{(\text{distance})^2}$
 \therefore Required ratio = y/x
12. No, the resultant of Tension in the string and weight of bob is not always towards the mean position.
13. $T = 2\pi/\omega$
14. Swinging through small angles.
15. No, it is a circular and periodic motion but not SHM.
16. In SHM, The velocity leads the displacement by a phase $\pi/2$ radians and acceleration leads the velocity by a phase $\pi/2$ radians.

17. The component of weight ($mg \sin \theta$).
18. $\sqrt{2}$ times, as $T \propto \sqrt{l}$
19. A harmonic wave function is a periodic function whose functional form is sine or cosine.
20. S.H.M.
21. Both amplitude and energy of the particle can be maximum only in the case of resonance, for resonance to occur $\omega_1 = \omega_2$.
22. Properties of elasticity and inertia.
23. When the sound wave travel through air adiabatic changes take place in the medium.
24. Sound travel faster in iron or solids because iron or solid is highly elastic as compared to water (liquids) or air (gases).
25. When the displacement of bob from the mean position is so small that $\sin \theta \approx \theta$.
26. $a = -4\pi^2 x = -\omega^2 x \Rightarrow \omega = 2\pi$

$$T = \frac{2\pi}{\omega} = \frac{2\pi}{2\pi} = 1s$$
27. The frequency of external periodic force is different from the natural frequency of the oscillator in case of forced oscillation but in resonance two frequencies are equal.
28. The maximum displacement of oscillating particle on either side of its mean position is called its amplitude.
29. A periodic motion repeats after a definite time interval T .
 So, $y(t) = y(t + T) = y(t + 2T)$ etc.
30. On a hot day, the velocity of sound will be more since (frequency proportional to velocity) the frequency of sound increases and hence its pitch increases.
31. On reflection from a denser medium, a wave suffers a sudden phase reversal.
32. If sounds are produced by different musical instruments simultaneously, then all these sounds are heard at the same time.

33. Explosion at the bottom of lake or sea create enormous increase in pressure of medium (water). A shock wave is thus a longitudinal wave travelling at a speed which is greater than that of ordinary wave.
34. When a wave passes through different media, velocity and wavelength change but frequency does not change.
35. Wave velocity is constant for a given medium and is given by $V = n\lambda$. But particle velocity changes harmonically with time and it is maximum at mean position and zero at extreme position.
36. The frequency of vibration depends on the length of the air column and not on reflecting media, hence frequency does not change.
37. Doppler effect will not be observed, if the source of sound moves towards the listener with a velocity greater than the velocity of sound. Same is also true if listener moves with velocity greater than the velocity of sound towards the source of sound.
38. Wave length of sound changes.
39. The number of sound waves received by the listener changes.
40. Yes, the sound waves will produce 56 beats every second. But due to persistence of hearing, we would not be able to hear these beats.
41. A medium in which speed of wave motion is independent of frequency of wave is called non-dispersive medium. For sound, air is non dispersive medium.

ANSWERS OF TWO MARKS QUESTIONS

42. Condition (i) is not sufficient, because direction of acceleration is not mentioned. In SHM, the acceleration is always in a direction opposite to that of the displacement.
43. Although length of the spring does not appear in the expression for the time period, yet the time period depends on the length of the spring. It is because, force constant of the spring depends on the length of the spring.
44. The time period of the liquid in a U-tube executing S.H.M. does not depend upon density of the liquid, therefore time period will be same, when the mercury is filled up to the same height in place of water in the U-tube.

45. We have, $v = \frac{1}{2\pi} \sqrt{\frac{k}{m}} = \frac{1}{2\pi} \sqrt{\frac{g}{l}}$

So, when a hard spring is loaded with a mass m . The extension l will be lesser w.r.t. delicate one. So frequency of the oscillation of the hard spring will be more and if time period is asked it will be lesser.

46. Restoring force in case of simple pendulum is given by

$$F = \frac{mg}{l} y \Rightarrow K = mg/l$$

So force constant itself proportional to m as the value of k is substituted in the formula, m is cancelled out.

47. The pendulum is in a state of weightlessness *i.e.* $g = 0$. The frequency of pendulum

$$v = \frac{1}{2\pi} \sqrt{\frac{g}{l}} = 0$$

48. $A_{\max} = \omega^2 a = A_0$, $U_{\max} = \omega a = v_0$

$$\Rightarrow \omega = \frac{v_0}{a}$$

$$\therefore a = \frac{A_0}{\omega^2} \Rightarrow a = \frac{A_0}{v_0^2} a^2$$

$$\Rightarrow a = \frac{v_0^2}{A_0}$$

49. At a given temperature, the velocity of sound is independent of pressure, so velocity of sound in tube will remain 330 ms^{-1} .

50. Two prongs of a tuning fork set each other in resonant vibrations and help to maintain the vibrations for a longer time.

51. When the stem of the a tuning fork gently pressed against the top of sonometer box, the air enclosed in box also vibrates and increases the intensity of sound. The holes bring the inside air incontact with the outside air and check the effect of elastic fatigue.

52. The displacement at any time t is

$$y = a \sin (\omega t + \phi)$$

\therefore displacement at any time $(t + 2\pi/\omega)$ will be

$$y = a \sin [\omega (t + 2\pi/\omega) + \phi] = [\sin \{\omega t + \phi + 2\pi\}]$$

$$y = a \sin (\omega t + \phi) \quad [\because \sin (2\pi + \phi) = \sin \phi]$$

Hence, the displacement at time t and $(t + 2\pi/\omega)$ are same.

53. When a number of waves travel through the same region at the same time, each wave travels independently as if all other waves were absent.

This characteristic of wave is known as independent behaviour of waves. For example we can distinguish different sounds in a full orchestra.

54. Wave number is the number of waves present in a unit distance of medium. ($\bar{v} = 1/\lambda$) S.I. unit of k is rad m^{-1} .

Angular wave number or propagation constant is $2\pi/\lambda$. It represents phase change per unit path difference and denoted by $k = 2\pi/\lambda$. S.I. unit of k is rad m^{-1} .

55. Because the density of water vapour is less than that of the dry air hence density of air decreases with the increase of water vapours or humidity and velocity of sound inversely proportional to square root of density.

56. Given, $v = \sqrt{\frac{\gamma P}{\rho}}$

(a) Let V be the volume of 1 mole of air, then

$$\rho = \frac{M}{V} \quad \text{or} \quad V = \frac{M}{\rho}$$

for 1 mole of air $PV = RT$

$$\therefore \frac{PM}{\rho} = RT \quad \text{or} \quad \frac{P}{\rho} = \frac{RT}{M}$$

$$\Rightarrow v = \sqrt{\frac{\gamma RT}{M}} \quad \dots(i)$$

So at constant temperature v is constant as γ , R and M are constant.

- (b) From equation (i) we know that $v \propto \sqrt{T}$, so with the increase in temperature velocity of sound increases.
57. (i) In a pipe open at both ends, the frequency of fundamental note produced is twice as that produced by a closed pipe of same length.
- (ii) An open pipe produces all the harmonics, while in a closed pipe, the even harmonics are absent,
58. Bats emit ultrasonic waves of very small wavelength (high frequencies) and so high speed. The reflected waves from an obstacle in their path give them idea about the distance, direction, nature and size of the obstacle.
59. At the point, where a compression and a rarefaction meet, the displacement is minimum and it is called displacement node. At this point, pressure difference is maximum *i.e.* at the same point it is a pressure antinode. On the other hand, at the mid point of compression or a rarefaction, the displacement variation is maximum *i.e.* such a point is pressure node, as pressure variation is minimum at such point.
60. As the temperature increases, the length of the prong of the tuning fork increases. This increases the wavelength of the stationary waves set up in the tuning fork. As frequency, $v \propto \sqrt{\frac{1}{\lambda}}$, so frequency of the tuning fork decreases.
61. For an echo of a simple sound to be heard, the minimum distance between the speaker and the walls should be 17 m, so in any room having length less than 17 m, our ears can not distinguish between sound received directly and sound received after reflection.
62. The phenomenon of persistence or prolongation of sound after the source has stopped emitting sound is called reverberation. The time for which the sound persists until it becomes inaudible is called the reverberation time.

SOLUTION / HINTS OF NUMERICALS

86.
$$y = r \sin \omega t = r \sin \frac{2\pi}{T} t$$

Here $y = \frac{1}{3}r$ and $T = 1s$

$$\therefore \frac{1}{\sqrt{2}}r = r \sin \frac{2\pi}{T} t \Rightarrow 2\pi t = \frac{\pi}{4} \Rightarrow t = \frac{1}{8}s.$$

87. When $x = x_1, v = u_1$

When $x = x_2, v = u_2$

$$\text{As } v = \omega\sqrt{A^2 - x^2}$$

$$\therefore u_1 = \omega\sqrt{A^2 - x_1^2} \quad \text{or} \quad u_1^2 = \omega^2(A^2 - x_1^2) \quad \dots\text{(i)}$$

$$\text{and } u_2 = \omega\sqrt{A^2 - x_2^2} \quad \text{or} \quad u_2^2 = \omega^2(A^2 - x_2^2) \quad \dots\text{(ii)}$$

Subtracting (ii) from (i), we get

$$u_1^2 - u_2^2 = (A^2 - x_1^2) - \omega^2(A^2 - x_2^2) = \omega^2(x_2^2 - x_1^2)$$

$$\text{or} \quad \omega = \left[\frac{u_1^2 - u_2^2}{x_2^2 - x_1^2} \right]^{1/2}$$

$$T = \frac{2\pi}{\omega} = 2\pi \left[\frac{x_2^2 - x_1^2}{u_1^2 - u_2^2} \right]^{1/2}$$

88. Here $y = 5 \text{ cm}$ and acceleration $a = 45 \text{ cm s}^{-2}$

We know $a = \omega^2 y$

$$\therefore 45 = \omega^2 \times 5 \quad \text{or} \quad \omega = 3 \text{ rad s}^{-1}$$

$$\text{and } T = \frac{2\pi}{\omega} = \frac{2\pi}{3} = 2.095 \text{ s.}$$

89. Here $mg = 40 \text{ g} = 40 \times 980 \text{ dyne}$; $l = 4 \text{ cm}$.

say k is the force constant of spring, then

$$mg = kl \quad \text{or} \quad k = mg/l$$

$$k = \frac{40 \times 980}{4} = 9800 \text{ dyne cm}^{-1}$$

when the spring is loaded with mass $m = 200 \text{ g}$

$$\begin{aligned} v &= \frac{1}{2\pi} \sqrt{\frac{k}{m}} = \frac{1}{2\pi} \sqrt{\frac{9800}{200}} \\ &= 1.113 \text{ s}^{-1}. \end{aligned}$$

90. Here on earth, $T = 3.5 \text{ s}$; $g = 9.8 \text{ ms}^{-2}$

For simple pendulum $T = 2\pi\sqrt{\frac{l}{g}}$

$$3.5 = 2\pi\sqrt{\frac{l}{9.8}} \quad \dots\text{(i)}$$

on moon, $g' = 1.7 \text{ ms}^{-2}$ and if T' is time period

$$\text{then } T' = 2\pi\sqrt{\frac{l}{1.7}} \quad \dots\text{(ii)}$$

Dividing eqn. (ii) by eqn. (i), we get

$$\frac{T'}{3.5} = \sqrt{\frac{9.8}{1.7}} \quad \text{or } T' = \sqrt{\frac{9.8}{1.7}} \times 3.5 = 8.4 \text{ s}$$

91. (i) $\frac{1}{2}m\omega^2(a^2 - y^2) = \frac{1}{2}m\omega^2 y^2 \Rightarrow y = \frac{a}{\sqrt{2}}$

(ii) $v = \omega\sqrt{a^2 - y^2} \Rightarrow a\omega = \omega\sqrt{a^2 - y^2} \Rightarrow y = \pm \frac{a\sqrt{3}}{2}$.

92. Let frequency of Ist tuning fork = x

frequency of IInd tuning fork = $x + 4$

frequency of IIIrd tuning fork = $x + 2$ (4)

frequency of IVth tuning fork = $x + 3$ (4)

\therefore Let frequency of 24th tuning fork = $x + 23$ (4)

octave means, (twice in freq.)

\therefore freq. of 24th = $2 \times$ freq. of Ist = $2x$

$\therefore 2x = x + 23$ (4) $\Rightarrow x = 92$

freq. of 24th = $2 \times 92 = 184 \text{ Hz}$.

93. Given, $v = 0.5 \text{ s}^{-1}$, $g = 9.8 \text{ ms}^{-1}$

$$a = \omega^2 y = (2\pi v)^2 y = 4\pi^2 v^2 y$$

a_{max} at the extreme position *i.e.*, $r = y$

$a_{\text{max}} = 4\pi^2 v^2 r$ and $a_{\text{max}} = g$ to remain in contact.

$$\text{or } r = \frac{g}{4\pi^2 v^2} = \frac{9.8}{4\pi^2 \times (0.5)^2} = 0.993 \text{ m.}$$

94. Say v_1 in the velocity of sound at $T_1 = 273^\circ\text{K}$ and $v_2 = 2v_1$ at temperature T_2

$$\text{Now } \frac{v_2}{v_1} = \sqrt{\frac{T_2}{T_1}}, \quad \therefore \frac{2v_1}{v_1} = \sqrt{\frac{T_2}{273}}$$

$$\text{or } T_2 = 4 \times 273 = 1092^\circ\text{K.}$$

95. Here $m = 50 \text{ kg}$, $l = 0.2 \text{ m}$

$$\text{we know } mg = kl \text{ or } k = \frac{mg}{l} = \frac{50 \times 9.8}{0.2} = 2450 \text{ Nm}^{-1}$$

$T = 0.60 \text{ s}$ and M is the mass of the body, then using

$$T = 2\pi\sqrt{\frac{M}{k}} \Rightarrow M = \frac{2450 \times (0.60)^2}{4\pi^2} = 22.34 \text{ kg}$$

$$\text{Weight of body } Mg = 22.34 \times 9.8 = 218.93 \text{ N.}$$

96. Apparent freq.

$$v' = \left(\frac{v - v_0}{v} \right) v \quad \text{or} \quad \frac{v'}{v} = \frac{v - v_0}{v}$$

$$\frac{v'}{v} = \frac{900}{1000} = \frac{9}{10}, \quad v = 330 \text{ ms}^{-1}$$

$$\therefore \frac{9}{10} = \frac{330 - v_0}{330}$$

$$330 - v_0 = \frac{9}{10} \times 330 = 297$$

$$v_0 = 330 - 297 = 33 \text{ m/s.}$$

$$97. \quad \text{KE} = \frac{1}{2} m\omega^2 (a^2 - y^2)$$

$$\text{at } y = \frac{a}{2}$$

$$\text{KE} = \frac{1}{2} m\omega^2 \left[a^2 - \left(\frac{a}{2} \right)^2 \right] = \frac{1}{2} m\omega^2 \cdot \frac{3a^2}{4}$$

$$\text{PE} = \frac{1}{2} m \omega^2 y^2 = \frac{1}{2} m \omega^2 \frac{a^2}{4}$$

$$\frac{\text{KE}}{\text{PE}} = \frac{3}{1}$$

98. Given $T = 200$ N, length of string $l = 20$ m

total mass of the string = 2.5 kg

\therefore mass per unit length of the string

$$m = \frac{2.5}{20} = 0.125 \text{ kg } m^{-1}$$

$$\text{Now } v = \sqrt{\frac{T}{m}} = \sqrt{\frac{200}{0.125}} = 40 \text{ ms}^{-1}$$

Hence time taken by the transverse wave to reach other end

$$t = \frac{l}{v} = \frac{20}{40} = 0.5 \text{ s.}$$

$$\begin{aligned} 99. \text{ (i) } \sin \omega t + \cos \omega t &= \sqrt{2} \left[\frac{1}{\sqrt{2}} \sin \omega t + \frac{1}{\sqrt{2}} \cos \omega t \right] \\ &= \sqrt{2} \sin \left(\omega t + \frac{\pi}{4} \right) \end{aligned}$$

It is simple harmonic function with period = $\frac{2\pi}{\omega}$

(ii) $\sin \omega t + \sin 2\omega t + \sin 4\omega t$ is a periodic but not simple harmonic function.

Its time period is $\frac{2\pi}{\omega}$.

(iii) $e^{-\omega t}$ is exponential function, which never repeat itself. Hence it is non-periodic function.

(iv) $\log \omega t$ is also non-periodic function.

100. Here $y = 10 \sin 200(t - 0.005x)$

$$y = 10 \sin \frac{2\pi}{200} (200t - x) \quad \dots(i)$$

The equation of a travelling wave is given by

$$y = a \sin \frac{2\pi}{\lambda} (vt - x) \quad \dots(\text{ii})$$

Comparing the equation (i) and (ii), we have

$$\alpha = 10 \text{ cm}, \lambda = 200 \text{ cm and } v = 200 \text{ ms}^{-1}$$

$$\text{Now } v = \frac{v}{\lambda} = \frac{200}{200} = 1 \text{ Hz}$$

101. Unknown freq. = Known freq. I Beat freq.

$$= 288 \pm 4 = 292 \text{ or } 284 \text{ Hz}$$

On putting wax, freq. decreases, beat freq. is also decrease to 2

\therefore unknown freq. = 292 Hz (higher one)

102. The frequency of n^{th} mode of vibration of a pipe closed at one end is given by

$$v_n = \frac{(2n-1)v}{4L}$$

river $v = 340 \text{ ms}^{-1}$, $L = 20 \text{ cm} = 0.2 \text{ m}$; $v_n = 430 \text{ Hz}$

$$\therefore 430 = \frac{(2n-1) \times 340}{4 \times 0.2} \Rightarrow n = 1$$

Therefore, first mode of vibration of the pipe is excited, for open pipe since n must be an integer, the same source can not be in resonance with the pipe with both ends open.

103. Total length of the wire, $L = 105 \text{ cm}$

$$v_1 : v_2 : v_3 = 1 : 3 : 15$$

Let L_1, L_2 and L_3 be the length of the three parts. As $v \propto \frac{1}{L}$

$$\therefore L_1 : L_2 : L_3 = 1 : \frac{1}{3} : \frac{1}{15} = 15 : 5 : 1$$

Sum of the ratios = $15 + 5 + 1 = 21$

$$\therefore L_1 = \frac{15}{21} \times 105 = 75 \text{ cm}; L_2 = \frac{5}{21} \times 105 = 25 \text{ cm};$$

$$L_3 = \frac{1}{21} \times 105 = 5 \text{ cm}$$

Hence the bridges should be placed at 75 cm and $(75 + 25) = 100$ cm from one end.

104. $y(x,t) = 0.06 \sin \frac{2\pi}{3} \times \cos 120 \pi t$ (i)

(a) The displacement which involves harmonic functions of x and t separately represents a stationary wave and the displacement, which is harmonic function of the form $(vt \pm x)$, represents a travelling wave. Hence, the equation given above represents a stationary wave.

(b) When a wave pulse $y_1 = a \sin \frac{2\pi}{\lambda} (vt - x)$ travelling along x -axis is superimposed by the reflected pulse.

$y_2 = -a \sin \frac{2\pi}{\lambda} (vt + x)$ from the other end, a stationary wave is formed and is given by

$$y = y_1 + y_2 = -2a \sin \frac{2\pi}{\lambda} \times \cos \frac{2\pi}{\lambda} vt$$
(ii)

Comparing the eqs. (i) and (ii), we have

$$\frac{2\pi}{\lambda} = \frac{2\pi}{3} \text{ or } \lambda = 3\text{m}$$

$$\frac{2\pi}{\lambda} v = 120\pi \text{ or } v = 60\lambda = 60 \times 3 = 180 \text{ ms}^{-1}$$

Now frequency $\gamma = \frac{v}{\lambda} = \frac{180}{3} = 60 \text{ Hz}$

(c) Velocity of transverse wave in a string is given by

$$v = \sqrt{\frac{T}{m}}$$

Here $m = \frac{3 \times 10^{-2}}{1.5} = 2 \times 10^{-2} \text{ kgm}^{-1}$

Also $v = 180 \text{ ms}^{-1}$

$\therefore T = v^2 m = (180)^2 \times 2 \times 10^{-2} = 648\text{N}$.

105. Frequency of fundamental mode, $\nu = 45\text{Hz}$

Mass of wire $M = 3.5 \times 10^{-2} \text{ kg}$; mass per unit length, $m = 4.0 \times 10^{-2} \text{ kgm}^{-1}$

$$\therefore \text{Length of wire } L = \frac{M}{m} = \frac{3.5 \times 10^{-2}}{4.0 \times 10^{-2}} = 0.875 \text{ m}$$

(a) For fundamental mode $L = \frac{\lambda}{2}$ or $\lambda = 2L = 0.875 \times 2 = 1.75 \text{ m}$

$$\therefore \text{velocity } v = \nu\lambda = 45 \times 1.75 = 78.75 \text{ ms}^{-1}$$

(b) The velocity of transverse wave

$$v = \sqrt{\frac{T}{m}} \Rightarrow T = v^2 m = (78.75)^2 \times 4.0 \times 10^{-2} = 248.6 \text{ N}$$

106. Given : $u = 2.53 \text{ kHz} = 2.53 \times 10^3 \text{ Hz}$

(L) Length of steel rod = 100 cm = 1 m.

when the steel rod clamped at its middle executes longitudinal vibrations of its fundamental frequency, then

$$L = \frac{\lambda}{2} \text{ or } \lambda = 2L = 2 \times 1 = 2 \text{ m}$$

The speed of sound in steel

$$v = n\lambda = 2.53 \times 10^3 \times 2 = 5.06 \times 10^3 \text{ ms}^{-1}.$$

107. $\Delta\phi = 60^\circ = 60 \times \frac{\pi}{180} = \frac{\pi}{3} \text{ rad.}$

$$v = \nu\lambda \Rightarrow \lambda = \frac{v}{\nu} = \frac{360}{500} = 0.72 \text{ m}$$

As $\Delta\phi = \frac{2\pi}{\lambda} \cdot \Delta x$

$$\begin{aligned} \Delta x &= \frac{\lambda}{2\pi} \times \Delta\phi = \frac{\pi}{3} \times \frac{0.72}{2\pi} \\ &= 0.12 \text{ m.} \end{aligned}$$

108. $v_0 = -\frac{v}{5}, v_s = 0$

Apparent freq. $\nu' = \left(\frac{v - v_0}{v - v_s} \right) \nu$

115. The instantaneous displacement of a simple pendulum oscillator is given by $x = A \cos \left(\omega t + \frac{\pi}{4} \right)$. If speed will be maximum at time
- (a) $\frac{\pi}{4\omega}$ (b) $\frac{\pi}{2\omega}$
 (c) $\frac{\pi}{\omega}$ (d) $\frac{2\pi}{\omega}$
116. The velocity of particle in SHM at displacement y from mean position is
- (a) $w\sqrt{(a^2 + y^2)}$ (b) $w\sqrt{(a^2 - y^2)}$
 (c) wy (d) $w^2\sqrt{a^2 + y^2}$
117. A particle is executing SHM with a period of T seconds and amplitude a meter. The shortest time it takes to reach a point $\frac{a}{\sqrt{2}}$ m from its mean position in seconds is
- (a) T (b) $\frac{T}{8}$
 (c) $\frac{T}{4}$ (d) $\frac{T}{16}$
118. Displacement between maximum potential energy position and maximum kinetic energy position for a particle executing SHM is
- (a) $-a$ (b) $+a$
 (c) $\pm a$ (d) $\pm \frac{a}{4}$
119. If tension in the string is increased from 1 KN to 4 KN, other factors remaining unchanged, the frequency of the second harmonic will
- (a) be halved (b) main changed
 (c) be doubled (d) becomes four times
120. An open organ pipe and a closed organ pipe have the frequency of their first overtone identical. What is the ratio of their lengths?
- (a) $\frac{1}{2}$ (b) $\frac{4}{3}$
 (c) $\frac{3}{4}$ (d) 1
121. The fundamental frequency of a stretched string is ν_0 . If the length is reduced by 35% and tension increased by 69% the fundamental frequency will be
- (a) $0.2 \nu_0$ (b) $0.5 \nu_0$
 (c) $2.0 \nu_0$ (d) $1.6 \nu_0$

122. Two waves of same frequency traveling in the same medium in opposite direction when super imposed give rise to
- (a) beats (b) harmonics
(c) standing waves (d) resonance
123. Equation of a progressive wave is given by $y = 0.2 \cos \pi \left\{ (0.04 t + 0.02 x) - \frac{\pi}{6} \right\}$ The distance is expressed in cm and time in second. What will be the minimum distance between two particles having the phase difference of $\pi/2$?
- (a) 4 cm (b) 8 cm
(c) 25 cm (d) 12.5 cm
124. For two systems to be in resonance, which of the following properties should be equal?
- (a) Wavelength (b) Frequency
(c) Amplitude (d) Wave velocity
125. Fundamental frequency of a sonometer wire is n . If the length, diameter and tension are doubled, the new fundamental frequency will be
- (a) n (b) $\sqrt{2} n$
(c) $\frac{n}{\sqrt{2}}$ (d) $\frac{n}{2\sqrt{2}}$
126. The frequency of an open organ pipe is ν . If half part of organ pipe is dipped in water then its frequency is
- (a) ν (b) $\frac{\nu}{2}$
(c) $\frac{\nu}{4}$ (d) O
127. Two tuning forks when sounded together given one beat every 0.2 s. What is the difference of frequencies?
- (a) 0.2 (b) 2
(c) 5 (d) 10
128. Angle between wave velocity and particle velocity of a longitudinal wave is
- (a) 90° (b) 60°
(c) 0° (d) 120°

Answer : (Objective Type Questions)

109. (c) 110. (c) 111. (b) 112. (c) 113. (b) 114. (c)
115. (a) 116. (b) 117. (c) 118. (c) 119. (c) 120. (c)
121. (c) 122. (c) 123. (c) 124. (b) 125. (d) 126. (a)
127. (c) 128. (c)

HINTS :

109. $y = a \sin \omega t$ as $y = \frac{a}{2}$ we get $t = \frac{1}{4}T$ (Given $T = 3s$)

111. $V_{\max} = a \omega = \frac{5}{100} \times \frac{2\pi}{2} \text{ m/s}$

114. $\omega t = 0.5\pi \Rightarrow \omega = 0.5\pi \Rightarrow T = 4s$ req. time $= \frac{T}{4} = 1s$

117. $y = a \sin \omega t$ $y = \frac{1}{\sqrt{2}}$

119. $v \propto \sqrt{T}$

120. For open pipe, frequency of I overtone, $v_1 = \frac{1}{L_1} \sqrt{\frac{\gamma P}{\rho}}$

For closed organ pipe, frequency of I overtone, $v_2 = \frac{3}{4L_2} \sqrt{\frac{\gamma P}{\rho}}$

121. $v_0 = \frac{1}{2L} \sqrt{\frac{T}{M}}$ Frequency in new cond. $v = \frac{1}{2(65\% \text{ of } L)} \sqrt{\frac{T + 69\% \text{ of } T}{M}}$

123. Req. distance $= \frac{\lambda}{4}$

CLASS: XI
SESSION: 2023-24
SOLVED PRACTICE PAPER
SUBJECT: PHYSICS (THEORY)

Maximum Marks: 70

Time Allowed: 3 hours.

General Instructions:

1. There are 33 questions in all. All questions are compulsory.
2. This question paper has five sections: Section A, Section B, Section C, Section D and Section E.
3. All the sections are compulsory.
4. Section A contains sixteen questions, twelve McQ and four Assertion Reasoning based of 1 mark each, Section B contains five questions of two marks each, Section C contains seven questions of three marks each, Section D contains two case study-based questions of four marks each and Section E contains three long answer questions of five marks each.
5. There is no overall choice. However, an internal choice has been provided in one question in Section B, one question in Section C, one question in each CBQ in Section D and all three questions in Section E. You have to attempt only one of the choices in such questions.
6. Use of calculators is not allowed.

SECTION-A

1. When 1 m, 1 kg and 1 min are taken as the fundamental units, the magnitude of the force is 36 units. What will be the value of this force in CGS system?
(a) 10^5 dyne (b) 10^3 dyne (c) 10^8 dyne (d) 10^4 dyne
2. The speed-time graph of a particle moving along a fixed direction is as shown in the figure. The distance traversed by the particle between $t = 0$ s to $t = 10$ s is

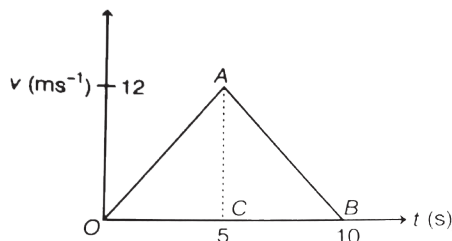

- (a) 20m (b) 40 m (c) 60 m (d) 80 m
3. When a ball is thrown obliquely from the ground level, then the x-component of the velocity
- (a) decreases with time (b) increases with time
(c) remains constant (d) zero
4. A body of mass 5×10^3 kg moving with speed 2 ms^{-1} collides with a body of mass 15×10^3 kg inelastically and sticks to it. Then, loss in kinetic energy of the system will be
- (a) 7.5 kJ (b) 15 kJ (c) 10 kJ (d) 5 kJ
5. The potential energy of a spring increases by 15 J when stretched by 3 cm. if it is stretched by 4 cm, the increase in potential energy is
- (a) 27 J (b) 30 J (c) 33 J (d) 36 J
6. A ball kept in a closed box moves in the box making collisions with the walls. The box is kept on a smooth surface. The velocity of the centre of mass
- (a) of the box remains constant
(b) of the box and the ball system remains constant
(c) of the ball remains constant
(d) of the ball relative to the box remains constant
7. The maximum load a wire can withstand without breaking, when its length is reduced to half of its original length will
- (a) be double (b) be half (c) be four times (d) remain same

8. A vertical U-tube of uniform inner cross section contains mercury in both sides of its arms. A glycerine (density = 1.3 g/cm^3) column of length 10 cm is introduced into one of its arms. Oil of density 0.8 gm/cm^3 is poured into the other arm until the upper surfaces of the oil and glycerine are in the same horizontal level. Find the length of the oil column, if Density of mercury = 13.6 g/cm^3

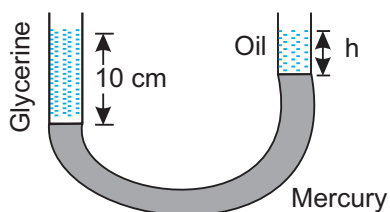

- (a) 10.4 cm (b) 8.2 cm (c) 7.2 cm (d) 9.6 cm

9. When a copper ball is heated, the largest percentage increase will occur in its
 (a) 10.4 cm (b) 8.2 cm (c) 7.2 cm (d) 9.6 cm
10. One mole of a monoatomic ideal gas is mixed with one mole of a diatomic ideal gas. The molar specific heat of the mixture at constant volume is
 (a) 8R (b) 1.5 R (c) 2R (d) 2.5 R
11. The amplitude and the periodic time of a S.H.M. are 5cm and 6sec respectively. At a distance of 2.5cm away from the mean position, the phase will be
 (a) $5\pi/12$ (b) $\pi/4$ (c) $\pi/3$ (d) $\pi/6$
12. Two monoatomic ideal gases 1 and 2 of molecular masses m_1 and m_2 respectively are enclosed in separate containers kept at the same temperature. The ratio of the speed of sound in gas 1 to that in gas 2 is given by
 (a) $\sqrt{m_1/m_2}$ (b) $\sqrt{m_2/m_1}$ (c) m_1/m_2 (d) m_2/m_1

For 13 to 14, was given one labelled Assertion (A) and her bed Reason (R). Select the correct answer to these questions from the options as given below

- (a) both Accertion and Reason are true and Reason is correct explanation of Assertion
- (b) if both Assertion and Reason are true but Reason is not the correct explanation of Assertion
- (c) Assertion is true but Reason is false
- (d) both Assertion and Reason are false.
13. **Assertion (A):** Product of distance and velocity (i.e. momentum) is basic to the effect of force on motion.
Reason (R): Same force for same time causes the same change in momentum for different bodies.
14. **Assertion (A):** As we go up the surface of the earth, we feel light weighed than on the surface of the earth.
Reason (R): The acceleration due to gravity decreases on going up above the surface of the earth.
15. **Assertion (A):** To empty an oil tank, two holes are made
Reason (R): Oil comes out from two holes so it will empty faster.

16. Assertion (A): When a bottle of cold carbonated drink is opened, a slight fog forms around the opening.

Reason (R): Adiabatic expansion of the gas causes lowering of temperature and condensation of water vapours.

SECTION-B

- 17.** A calorie is a unit of heat (energy in transit) and it equals about 4.2 J where $1\text{ J} = 1\text{ kg m}^2\text{ s}^{-2}$. Suppose we employ a system of units in which the unit of mass equals a kg, the unit of length equals β m, the unit of time is γ s. Show that a calorie has a magnitude $4.2\alpha^{-1}\beta^{-2}\gamma^2$ in terms of the new units.
- 18.** A constant retarding force of 50 N is applied to a body of mass 20 kg moving initially with a speed of 15 m s^{-1} . How long does the body take to stop?
- 19.** Two bodies have their moments of inertia I and $2I$ respectively about their axis of rotation. If their kinetic energies of rotation are equal then their angular momenta will be in the ratio of?
- 20.** Explain the stress strain curve for a metallic wire.

OR

State and prove Pascal's law.

- 21.** A spring balance has a scale that reads from 0 to 50 kg. The length of the scale is 20 cm. A body suspended from this balance, when displaced and released, oscillates with a period of 0.6 s. What is the weight of the body?

SECTION-C

- 22.** What are beats? How are they produced? Briefly discuss one application for this phenomenon.

OR

Describe the various modes of vibrations of a closed organ pipe. Show that only odd harmonics are present in closed organ pipe i.e., the ratio of different frequencies be 1:3:5:7....

- 23.** Derive an expression for the time period of vertical oscillations of a massless loaded spring.
- 24.** Three vessels of equal capacity have gases at the same temperature and pressure. The first vessel contains neon (monatomic), the second

contains chlorine (diatomic), and the third contains uranium hexafluoride (polyatomic). Do the vessels contain equal number of respective molecules? Is the root mean square speed of molecules the same in the three cases? If not, in which case is it the largest?

25. Define escape velocity. Deduce an expression for the escape velocity of a body from the surface of the earth.
26. What is elastic collision? Derive the expression for final velocities of the two bodies in terms of their initial velocities for an elastic collision in 1 Dimension.
27. What do you mean by banking of a curved road? Derive an expression for velocity of a car moving on a banked circular road having coefficient of friction μ .
28. State the law of parallelogram of vector addition and find the magnitude and direction of the resultant of two vectors inclined at an angle with each other.

OR

Derive kinematic equations of motion using graphical method where acceleration of body is constant.

SECTION-D

(Case Study Based Questions)

29. Read the following paragraph and answer the questions that follow.

Force of Friction on Connected Bodies

When bodies are in contact, there are mutual contact forces satisfying the third law of motion. The component of contact force normal to the surfaces in contact is called normal reaction. The component parallel to the surfaces in contact is called friction.

In the above figure, 8 kg and 6 kg are hanging stationary from a rough pulley and are about to move. They are stationary due to roughness of the pulley.

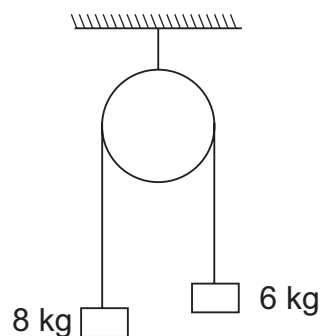

- (i) Which force is acting between pulley and rope?
- (a) Gravitational force (b) Tension force
(c) Frictional force (d) Buoyant force
- (ii) The normal reaction acting on the system is
- (a) 8 g (b) 6 g (c) 2 g (d) 14 g
- (iii) The tension is more on side having mass of
- (a) 8kg (b) 6 kg
(c) Same on both (d) Nothing can be said
- OR

The force of friction acting on the rope is

- (a) 20 N (b) 30 N (c) 40 N
- (iv) Coefficient of friction of the pulley is
- (a) $1/6$ (b) $1/7$ (c) $1/5$ (d) $1/4$

30. Read the following paragraph and answer the questions that follow.

HEAT TRANSFER

The figure shows the different modes of transfer of heat, heat transfer is defined as the movement of heat across the border of the system due to a difference in temperature between the system and its surroundings. The temperature difference exists between the two systems; heat will find a way to transfer from the higher to the lower system.

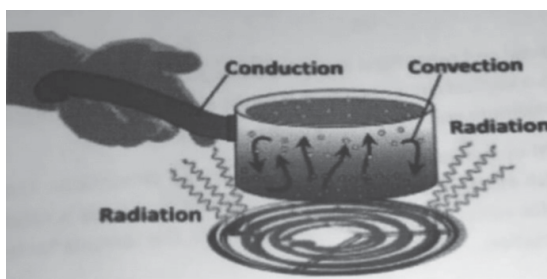

- (i) At what factor heat absorbed on radiation by the body depends on?
- (a) distance between body (b) source of heat
(c) its color (d) all of the above
- (ii) When heat is transferred by molecular collision, it is referred to as heat transfer by:

- (a) convection (b) conduction
(c) radiation (d) convection and radiation
- (iii) Thermal conductivity of air with rise in temperature:
(a) increase (b) decrease
(c) constant (d) none of these

OR

Mass transfer does not take place in:

- (a) conduction (b) convection (c) radiation (d) none of these
- (iv) A body takes 5 minute to cool from 80°C to 50°C . How much time it will take to cool from 60°C to 30°C , if room temperature is 20°C .
(a) 40 minutes (b) 9 minutes (c) 30 minutes (d) 20 minutes

SECTION-E

31. Define projectile. Show that the path of a projectile is parabolic. Deduce the expression for (a) time of flight (b) horizontal range (c) maximum height reached by a projectile, in terms of initial velocity and angle of projection.

OR

What are centripetal and centrifugal forces? A body attached to a string of length l describes a vertical circle such that it is just able to cross the highest point. Find the maximum velocity at the bottom of the circle.

32. Define moment of inertia of a body. Give its units and dimensions. Explain the factors on which moment of inertia of a body depends. A body is rotating with uniform angular velocity ω about an axis. Establish the formula for its kinetic energy of rotation.

OR

Deduce the expression of g on the earth surface. Also, discuss variation of ' g ' with depth and height. Plot the ' g ' vs ' r ' graph from the centre of earth.

33. Define an adiabatic process. State two essential conditions for such a process to takes place. Derive an expression for the work done during the adiabatic expansion of an ideal gas.

OR

- (a) Define streamlined flow. Write two properties of streamlines. Derive equation of continuity.
- (b) State and prove Bernoulli's principle for the flow of non-viscous fluids. Give its limitations.

CLASS: XI
SESSION: 2023-24
MARKING SCHEME
SUBJECT: PHYSICS (THEORY)

SECTION-A

1. Option (b)

As, dimensional formula of force = $[MLT^{-2}]$

$$n_1 = 36, M_1 = 1 \text{ kg}, L_1 = 1 \text{ m}, T_1 = 1 \text{ min} = 60 \text{ s},$$

$$n_2 = ?, M_2 = 1 \text{ g}, L_2 = 1 \text{ cm}, T_2 = 1 \text{ s}$$

So, conversion of 36 units into CGS system,

i.e.
$$n_2 = n_1 \left[\frac{M_1}{M_2} \right]^a \left[\frac{L_1}{L_2} \right]^b \left[\frac{T_1}{T_2} \right]^c$$

$$\begin{aligned} \Rightarrow n_2 &= n_1 \left[\frac{1 \text{ kg}}{1 \text{ g}} \right]^1 \left[\frac{1 \text{ m}}{1 \text{ cm}} \right]^1 \left[\frac{1 \text{ min}}{1 \text{ s}} \right]^{-2} \\ &= 36 \left[\frac{1000 \text{ g}}{1 \text{ g}} \right] \left[\frac{100 \text{ cm}}{1 \text{ cm}} \right]^1 \left[\frac{60 \text{ s}}{1 \text{ s}} \right]^{-2} \\ &= 10^3 \text{ dyne} \end{aligned}$$

2. Option (c)

Distance travelled by the particle between time interval $t = 0 \text{ s}$ to $t = 10 \text{ s}$

= Area of triangle OAB

$$= \frac{1}{2} \times \text{Base} \times \text{Height}$$

$$= \frac{1}{2} \times \text{OB} \times \text{AC}$$

$$= \frac{1}{2} \times 10 \times 12 = 60 \text{ m}$$

3. Option (c)

After the object has been projected, the x-component of the velocity remains constant throughout the motion and only the y-component changes, like an object in free-fall in vertical direction.

4. Option (a)

Given, mass of body, $m_1 = 5 \times 10^3 \text{ g}$

and mass of another body

$$m_2 = 15 \times 10^3 \text{ kg}$$

Velocity, $v_1 = 2 \text{ ms}^{-1}$

For perfectly inelastic collision ($e = 0$),

Loss in kinetic energy of system,

$$\begin{aligned} \text{DEK} &= \frac{1}{2} \frac{m_1 m_2}{m_1 + m_2} \times v_1^2 \\ &= \frac{1}{2} \times \frac{5 \times 10^3 \times 15 \times 10^3}{5 \times 10^3 + 15 \times 10^3} \times 2^2 \\ &= 7.5 \times 10^3 \text{ J} = 7.5 \text{ kJ} \end{aligned}$$

5. Option (a)

$$\text{PE of spring} = \frac{1}{2} kx^2 \Rightarrow PE \propto x^2$$

$$\therefore PE = 15 \times \frac{(4)^2}{(3)^2} = 15 \times \frac{16}{9} = 27 \text{ J}$$

6. Net external force on the system is zero. Hence, velocity of centre of mass of the box and ball system will remain constant.

Option (a)

7. The correct option is '(d) remain same' since Breaking stress is a constant for a given material and it does not depend upon the dimension (length or thickness) or wire.

8. Option (d)

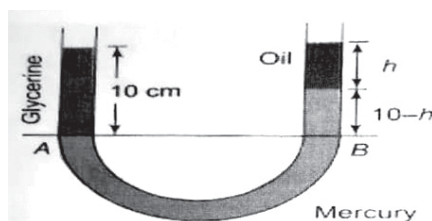

As the condition of equilibrium

Pressure at point A = Pressure at point B

$$P_A = P_B$$

$$\Rightarrow 10 \times 10.3 \times g = h \times 0.8 \times g + (10 - h) \times 13.6 \times g$$

After solving we get

$$h = 9.6 \text{ cm}$$

Hence the level of the oil column is 9.6 cm

9. (c) When a copper ball is heated, its size increases.

As Volume $\propto (\text{radius})^3$ and Area $\propto (\text{radius})^2$, so percentage increase will be temperature.

10. Option (c)

$$\begin{aligned}(C_V)_{\text{mix}} &= \frac{\mu_1 C_{V_1} + \mu_2 C_{V_2}}{\mu_1 + \mu_2} = \frac{1 + \frac{3}{2}R + 1 + \frac{5}{2}R}{1 + 1} = 2R \\ &= \left((C_V)_{\text{mono}} = \frac{3}{2}R, (C_V)_{\text{di}} = \frac{5}{2}R \right)\end{aligned}$$

11. Option (d)

(d) Equation of motion is $y = 5 \sin \frac{2\pi t}{6}$. For $y = 2.5$ cm

$$2.5 = 5 \sin \frac{2\pi t}{6} \Rightarrow \frac{2\pi t}{6} = \frac{\pi}{6} \Rightarrow t = \frac{1}{2} \text{ sec}$$

$$\text{and phase} = \frac{2\pi t}{6} = \frac{\pi}{6}$$

12. Option (b)

(b) Speed of sound in gases is given by

$$v = \sqrt{\frac{\gamma RT}{M}} \Rightarrow v \propto \frac{1}{\sqrt{M}} \Rightarrow \frac{v_1}{v_2} = \sqrt{\frac{m_2}{m_1}}$$

13. Option (d)

As we know, momentum, $p = mv$

Change in p can be brought by changing force. i.e.

$F = \frac{dp}{dt}$ = rate of change of momentum with time.

$$\Rightarrow m dv = F dt$$

So, in order to keep $F dt$ constant, $m dv$ should be constant, here m and dv can change from one body to another body.

Thus, same force for same time can cause different change in momentum for different bodies. Therefore, A is false and R is also false.

14. Option (a)

Variation of acceleration due to gravity at height is given by

$$g_h = \left(1 - \frac{2h}{R}\right)$$

Since, acceleration due to gravity decreases above the surface of the earth and weight is directly proportional to the acceleration due to gravity, so as we go up, we feel light weighted than on the surface of the earth. Therefore, both A and R are true and R is the correct explanation of A.

15. Option (c)

When two holes are made in the tin, air keeps on entering through the other hole. Due to this the pressure inside the tin does not become less than atmospheric pressure which happen only one hole is made

16. Option (a)

When a bottle of cold carbonated drink is opened. A slight fog forms around the opening. This is because of adiabatic expansion of gas causes lowering of temperature and condensation of water vapours

SECTION-E

17.

SI	New system
$n_1 = 4.2$	$n_2 = ?$
$M_1 = 1 \text{ kg}$	$M_2 = \alpha \text{ kg}$
$L_1 = 1 \text{ m}$	$L_2 = \beta \text{ m}$
$T_1 = 1 \text{ s}$	$T_2 = \gamma \text{ second}$

Dimensional formula of energy is $[M^1 L^2 T^{-2}]$

Comparing with $[M^a L^b T^c]$, we get

$$a = 1, b = 2, c = -2$$

Now,

$$n_2 = n_1 \left[\frac{M_1}{M_2} \right]^d \left[\frac{L_1}{L_2} \right]^b \left[\frac{T_1}{T_2} \right]^c$$

$$= 4.2 \left[\frac{1\text{kg}}{\alpha\text{kg}} \right]^1 \left[\frac{1\text{m}}{\beta\text{m}} \right]^2 \left[\frac{1\text{s}}{\gamma\text{s}} \right]^{-2}$$

or,

$$n_2 = 4.2 a^{-1} b^{-2} \gamma^2.$$

18. Given; $u = 15\text{m/s}$; $v = 0$; $t = ?$

$$F = 50\text{N}, m = 20 \text{ kg}$$

\therefore Retardation,

$$a = \frac{F}{m} = \frac{50}{20} = 2.5 \text{ ms}^{-2}$$

Now applying the equation, $v = u + at$

$$0 = 15 - 2.5t \Rightarrow 2.5 t = 15$$

or

$$t = \frac{15}{2.5} = 6 \text{ sec}$$

\therefore

$$t = 6 \text{ sec}$$

19. Rotational kinetic energy remains same.

i.e.
$$\frac{1}{2} I_1 \omega_1^2 = \frac{1}{2} I_2 \omega_2^2$$

or
$$\frac{1}{2I_1} (I\omega_1)^2 = \frac{1}{2I_2} (I_2\omega_2)^2$$

But

$$I_1 = I, I_2 = 2I$$

\Rightarrow

$$\frac{L_1}{L_2} = \sqrt{\frac{I}{2I}} = \frac{1}{\sqrt{2}} \Rightarrow L_1 : L_2 = 1 : \sqrt{2}$$

20.

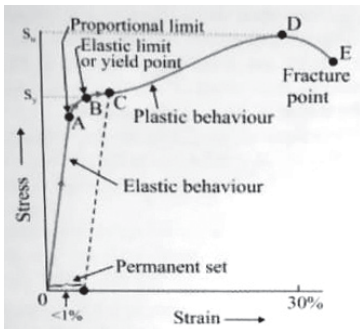

Pascal's law says that pressure applied to an enclosed fluid will be transmitted without a change in magnitude to every point of the fluid and the walls of the container. The pressure at any point in the fluid is equal in all directions.

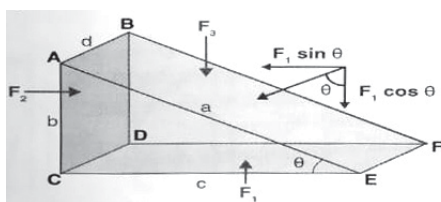

$$\sin \theta = \frac{b}{a}$$

$$\cos \theta = \frac{c}{a}$$

The net force on the prism will be zero since the prism is in equilibrium.

$$F_1 \sin \theta = F_2$$

$$F_1 \cos \theta = F_3$$

$$P_1 \text{ ad } b/a = P_2 \text{ bd (eq 1)}$$

$$P_1 \text{ ad } c/a = P_3 \text{ cd (eq 2)}$$

From 1 and 2

$$P_1 = P_2 \text{ and } P_1 = P_3$$

\therefore

$$P_1 = P_2 = P_3$$

21. $F = 50 \times 9.8 = 490 \text{ N}$

\therefore Spring constant (k):-

$$k = \frac{F}{l} = \frac{490}{0.2} = 2450 \text{ Nm}^{-1}$$

So, Time period:-

$$T = 2\pi \sqrt{\frac{m}{k}}$$

$$\therefore m = \left(\frac{T}{2\pi}\right)^2 \times k = \left(\frac{0.6}{2 \times 3.14}\right)^2 \times 2450 = 22.36 \text{ kg}$$

$$\therefore \text{Weight of the body} = mg = 22.36 \times 9.8 = 219.167 \text{ N}$$

Hence, the weight of the body is about 219 N.

SECTION-C

- 22.** The periodic rise and fall (Waxing and waning) in the intensity of sound due to the superposition of two sound waves of slightly different frequencies

traveling in the same direction is called beats. The phenomenon of beats can be used.

1. To determine the unknown frequency of a tuning fork.
2. In tuning musical instruments.

To understand this phenomenon, let us consider, two tuning forks of close frequencies, e.g., 700 Hz and 705 Hz as shown in fig.

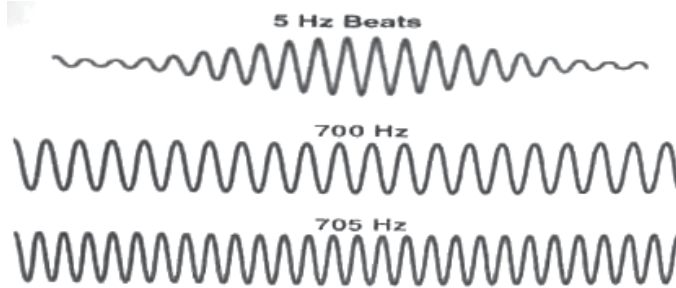

Both the frequencies are almost identical, and there is no significant difference in the audible frequency, but when played together these two frequencies, interfere with each other, as they are very close to each other in terms of frequencies their crest-crest interference produces a constructive interference and increases the amplitude of the wave hence the loudness of sound increases. When a crest-trough meet the interference produced will be destructive, therefore they both will cancel out, and the amplitude produced will be equal to zero; hence the loudness will reduce to zero, the frequency at which the loudness increases and decreases are known as the beat frequency, this beat frequency is equal to the difference between the two frequencies which produced it.

In our case, we have frequency A as 700 Hz, frequency B as 705 Hz; therefore, if these two frequencies interfere in time, the resultant beat frequency will be $705 - 700 \text{ Hz} = 5 \text{ Hz}$,

Piano tuners use this technique of beats and interference to tune piano wires finely; they pluck the wire and a tuning fork at the same time, and then depending on the beat's frequency, they will tighten or loosen the wire tension to increase or reduce the frequency thereby tuning the wire to the same frequency as the fork. Eventually, the beats vanish when the wire is perfectly in tune.

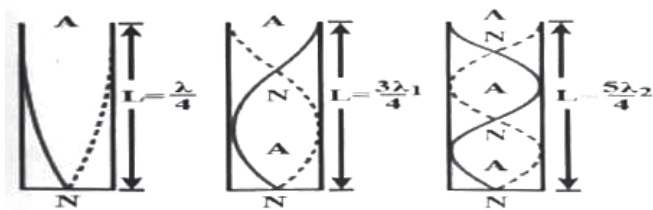

Consider the different modes of vibration of an air column within a pipe closed at one end. Let L be the length of the pipe. The standing waves are formed only for certain discrete frequencies.

In the first mode of vibration of the air column, there is one node and one antinode as shown in the figure above.

If λ is the length of the wave in the fundamental mode of vibration

Then, Length of the air column, $L = \lambda/4$

$$\Rightarrow \lambda = 4L \quad \dots(1)$$

As velocity of the wave, $v = n\lambda$

$$v = n\lambda$$

substituting (1) we get:

$$n = v/4L; \text{ Frequency of the fundamental mode}$$

Frequency of the fundamental mode in the second mode of vibration of the air column, two nodes and two antinodes are formed.

In this case:

The length of the air column, $L = 3\lambda_1/4$

where λ_1 is the wavelength of the wave in the second mode of vibration

$$\Rightarrow \lambda_1 = 4L/3 \quad \dots(1)$$

$$v = n_1\lambda_1$$

$$n_1 = v/\lambda_1$$

substituting (1), we get

$$n_1 = 3v/4L = 3n$$

This frequency is called the third harmonics or first overtone.

Similarly, during the third mode of vibration of the air column, three nodes and three antinodes are formed.

Here,

The length of the air column, $L = 5\lambda_2/4$

where λ_2 is the wavelength of the wave in third mode of vibration,

$$\Rightarrow \lambda_2 = 4L/5 \quad \dots(1)$$

$$n_2 = n_2\lambda_2$$

$$n_2 = v/\lambda_2$$

substituting (1) we get

$$n_2 = 5v/4L = 5n$$

This frequency is called the fifth harmonic or second overtone. Thus, we see that the frequencies of the modes of vibrations are in the ratio $n : n_1 : n_2 = 1 : 3 : 5$. This shows that only odd harmonics are present in the modes of vibrations of t air column closed at one end.

23.

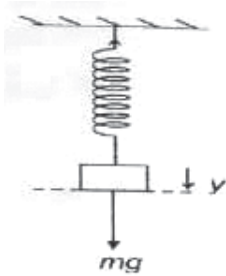

Let initial elongation of spring is Y .

At initial equilibrium

$$Ky_0 = mg \quad \dots(i)$$

Let the block is pulled down as shown in figure.

Hence net elongation in spring $= (y_0 + y)$

Now spring force $F = (y_0 + y)$

Now for motion of block

$$mg - F' = \frac{md^2y}{dt^2}$$

$$mg - k(y_0 + y) = \frac{md^2y}{dt^2}$$

$$\Rightarrow mg - ky_0 - ky = \frac{md^2y}{dt^2}$$

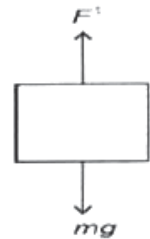

$$\Rightarrow \frac{m d^2 y}{dt^2} = -ky \text{ (for eqn. (i) } ky_0 = mg)$$

$$\Rightarrow \frac{d^2 y}{dt^2} = -\frac{k}{m} y = -\omega^2 y \text{ this is SHM}$$

$$\text{where } \omega^2 = \frac{k}{m}$$

$$\text{where } \omega = \sqrt{\frac{k}{m}} \Rightarrow T = \frac{2\pi}{\omega} = 2\pi\sqrt{\frac{m}{k}}$$

- 24.** All the three vessels have the same capacity, they have the same volume. Hence, each gas has the same pressure, volume, and temperature. According to Avogadro's law, the three vessels will contain an equal number of the respective molecules. This number is equal to Avogadro's number, $N = 6.023 \times 10^{23}$.

The root mean square speed (V_{rms}) of a gas of mass m , and temperature T , is given by the relation:

$$V_{\text{rms}} = \sqrt{\frac{3kT}{m}}$$

where, k is Boltzmann constant

For the given gases, k and T are constants.

Hence, V_{rms} depends only on the mass of the atoms, i.e., $V_{\text{rms}} \propto (1/m)^{1/2}$.

Therefore, the root mean square speed of the molecules in the three cases is not the same. Among neon, chlorine, and uranium hexafluoride, the mass of neon is the smallest. Hence, neon has the largest root mean square speed among the given gases.

- 25.** Escape velocity is the minimum velocity with which a body must be projected vertically upward so that it may just escape the surface of the Earth.

Work done to raise the body by distance dr is,

$$dw = \frac{GMm}{r^2} dr$$

Total work done. W in raising the body from the surface of the earth to infinity is,

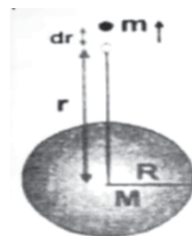

$$\begin{aligned}
 w &= \int_R^{\infty} \frac{GMm}{r^2} dr = GMm \left[-\frac{1}{r} \right]_R^{\infty} \\
 &= GMm \left[\frac{1}{\infty} + \frac{1}{R} \right] \\
 &= \frac{GMm}{R}
 \end{aligned}$$

If we throw the body upward with a velocity v_e , then work done to raise the body from surface of the earth to infinity is done by kinetic energy.

Therefore,

$$\begin{aligned}
 \frac{GMm}{R} &= \frac{1}{2}mv_e^2 \\
 \Rightarrow v_e &= \sqrt{\frac{2GM}{R}} = \sqrt{2gR} \\
 \Rightarrow v_e &= \sqrt{2gR} \quad \dots(1)
 \end{aligned}$$

Substituting the values in equation (1), we have

$$g = 9.81 \text{ m/sec} \text{ and } R = 6.4 \times 10^6 \text{ m}$$

Escape velocity is given by,

$$\begin{aligned}
 v_e &= \sqrt{9.81 \times 6.4 \times 10^6} \\
 &= 11200 \text{ m/s} \\
 &= 11.2 \text{ km/s}
 \end{aligned}$$

- 26.** An elastic collision is a collision in which there is no net loss in kinetic energy in the system as a result of the collision. Both momentum and kinetic energy are conserved quantities in elastic collisions.

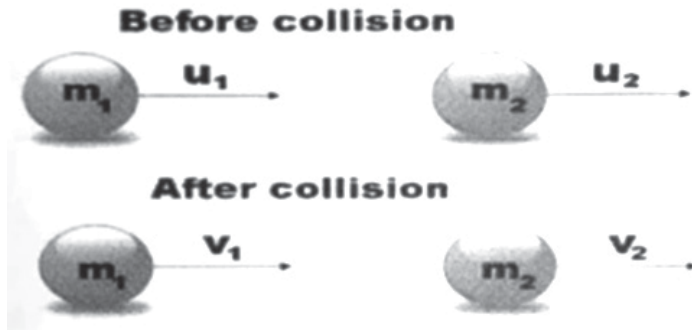

By conservation of momentum,

$$m_1 u_1 + m_2 u_2 = m_1 v_1 + m_2 v_2$$

$$\text{or } m_1(u_1 - v_1) = m_2(v_2 - u_2) \quad \dots(1)$$

By conservation of kinetic energy

$$\frac{1}{2} m_1 u_1^2 + \frac{1}{2} m_2 u_2^2 = \frac{1}{2} m_1 v_1^2 + \frac{1}{2} m_2 v_2^2$$

$$\text{or } m_1(u_1^2 - v_1^2) = m_2(v_2^2 - u_2^2) \quad \dots(2)$$

Dividing (2) by (1), we get,

$$(u_1 + v_1) = (v_2 + u_2)$$

$$\text{or } v_2 = u_1 - u_2 + v_1 \quad \dots(3)$$

Substituting (3) by (1), we get

$$m_1(u_1 - v_1) = m_2(u_1 - u_2 + v_1 - u_2)$$

$$\text{or } m_1 u_1 - m_1 v_1 = m_2 u_1 - m_2 u_1 - 2m_2 u_2 + m_2 u_1$$

$$\begin{aligned} \text{or } v_1 &= \frac{1}{2} m_1 v_1^2 + \frac{1}{2} m_2 v_2^2 \\ &= \frac{(m_1 - m_2)u_2 + 2m_1 u_1}{m_1 + m_2} \end{aligned}$$

27. Banking of roads is defined as the phenomenon in which the outer edges are raised for the curved roads above the inner edge to provide the necessary centripetal force to the vehicles so that they take a safe turn.

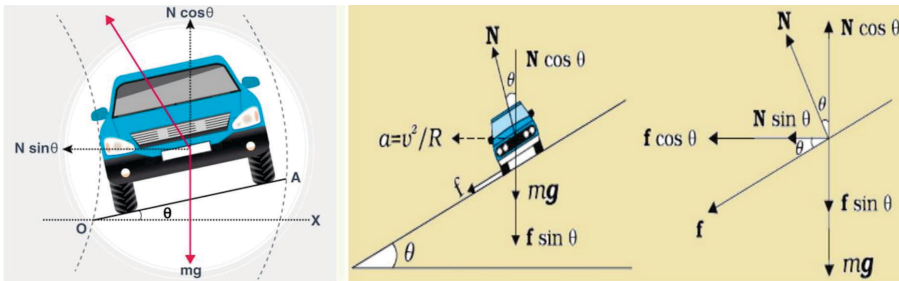

From the figure, for vertical equilibrium:

Total upwards force = total downwards force

$$N \cos \theta = mg + f \sin \theta$$

$$mg = N \cos \theta - f \sin \theta \quad \dots(1)$$

As the forces $N \sin \theta$, $f \cos \theta$ provide the necessary centripetal force.

$$\frac{mv^2}{r} = N \sin \theta + f \cos \theta \quad \dots(2)$$

Thus, dividing (2) by (1),

$$\frac{mv^2}{r} = \frac{N \sin \theta + f \cos \theta}{N \cos \theta - f \sin \theta}$$

As

$$f = \mu_s N$$

Thus,

$$\frac{v^2}{rg} = \frac{\sin \theta + \mu_s \cos \theta}{\cos \theta - \mu_s \sin \theta}$$

$$= \frac{\tan \theta + \mu_s}{1 - \mu_s \tan \theta} = \frac{\tan \theta + \tan \lambda}{1 - \tan \lambda \tan \theta}$$

$$= \tan(\theta + \lambda)$$

$$v = \sqrt{rg \tan(\theta + \lambda)} \quad \text{where } \tan \lambda = \mu_s$$

- 28.** The parallelogram law of vector addition states that, when two vectors are acting simultaneously, both in magnitude and direction, by the adjacent sides of a parallelogram drawn from the same point, then their resultant vector is represented both in magnitude and direction by the diagonal of the parallelogram also drawn from the same point.

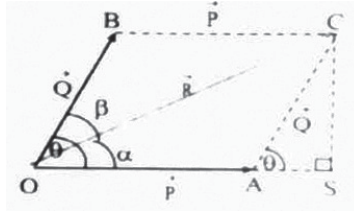

$$\therefore \angle CAS = \angle BOA = \theta \text{ and } AC = OB = Q \quad \dots(1)$$

In right angle triangle ASC,

$$\cos \theta = \frac{AS}{AC}$$

$$\therefore AS = AC \cos \theta = Q \cos \theta$$

and

$$\sin \theta = \frac{SC}{AC}$$

$$\therefore AS = AC \sin \theta = Q \sin \theta$$

From right angle triangle ASC,

$$(AS)^2 + (SC)^2 = (AC)^2$$

$$\therefore R^2 = P^2 + Q^2 + 2PQ \cos \theta$$

$$\therefore R = \sqrt{P^2 + Q^2 + 2PQ \cos \theta}$$

Direction of resultant vector

R make an angle α with P

In ΔOSC ,

$$\tan \alpha = \frac{SC}{OA + AS}$$

$$\tan \alpha = \frac{Q \sin \theta}{P + Q \cos \theta}$$

$$\alpha = \tan^{-1} \left(\frac{Q \sin \theta}{P + Q \cos \theta} \right)$$

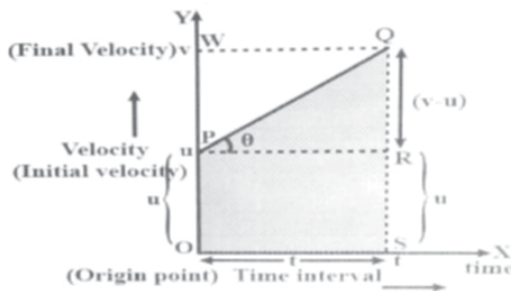

Graphical method: Consider an object moving along a straight line with uniform acceleration let u be the initial velocity of the object at time $t = 0$ and v be the final velocity of the object at time t . Let s be the distance travelled by the object in time t .

velocity-time graph of this motion is a straight line PQ as shown in the figure

where

$$OP = u = RS$$

$$OW = SQ = v \text{ and}$$

$$OS = PR = t$$

(I) for the first equation of motion: we know that the slope of velocity-time graph of uniformly accelerated motion represents the acceleration of the object

i.e. acceleration = slope of the velocity-time graph PQ

or

$$a = \frac{QR}{PR} = \frac{QR}{OS}$$

$$a = \frac{SQ - SR}{OS} = \frac{v - u}{t}$$

or $v - u = at$
 or $v = u + at$... (1)

This is the first equation of uniform accelerated motion.

- (ii) **Second equation of motion;** We know that the area under the velocity-time graph for a given time interval represents the distance covered by the uniformly accelerated object in that interval of time. Distance (displacement) travelled by the object in time t is:

$$S = \text{area of trapezium OSQP}$$

$$= \text{area of rectangle OSRP} + \text{Area of triangle PRQ}$$

or $S = OS \times OP + \frac{1}{2} \times PR \times PQ$
 (area of rectangle = length breadth)
 (Area of triangle = $\frac{1}{2}$ Base \times Height)
 $= t \times u + \frac{1}{2} \times t \times (v - u)$

(from the first equation of motion $v - u = at$)
 $= ut + \frac{1}{2} \times t \times at$

Thus $S = ut + \frac{1}{2} at^2$... (ii)

- (iii) **Third equation of motion:** Distance travelled by the object in time interval t is

$$s = \text{area of trapezium OSQP}$$

$$= \frac{1}{2} (OP + SQ) \times OS$$

$\therefore OP = SR$

$$= \frac{1}{2} (OP + SQ) \times OS$$
 ... (iii)

Acceleration, $a =$ slope of the velocity-time graph PQ

or $a = \frac{RQ}{PR} = \frac{SQ - SR}{OS}$

or $OS = \frac{SQ - SR}{a}$... (iv)

Putting this value in equation (iii) we get

$$S = \frac{1}{2}(SR + SQ) \left(\frac{SQ - SR}{a} \right)$$

or
$$s = \frac{1}{2a}(AQ^2 - SR^2)$$

or
$$s = \frac{1}{2a}(v^2 - u^2)$$

or
$$v^2 - u^2 = 2as$$

or
$$v = u^2 + 2as \quad \dots(v)$$

This the third equation of uniform accelerated motion.

SECTION-D (Case Study Based Questions)

29. (i) (c) Frictional force acts between pulley and rope.

(ii) (d) The reaction force is

$$R = T_1 + T_2 = (8 + 6) g = 14g$$

(iii) (a) As, tension, $T = mg \Rightarrow T \propto m$

So, the side having 8 kg mass will have more tension

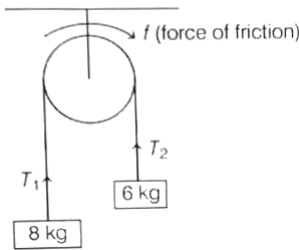

Due to friction, tension at all points of the thread is not alike.

$$T_1 - T_2 = f$$

$\Rightarrow f = 8g - 6g = 2g$

$$= 20 \text{ N} \quad (\because g = 10 \text{ ms}^{-2})$$

(iv) (b) As,

$$\mu R = f = 20 \text{ N}$$

$$\mu = \frac{20}{R} = \frac{20}{14 \times 10} = \frac{1}{7} \quad (\because R = mg)$$

30. (i) (d) all of the above.

(ii) (b) Conduction

(iii) (a) increase

OR

(c) radiation

(iv) (b) According to Newton's law of cooling

in first case,
$$\frac{80-50}{5} = K \left[\frac{80+50}{2} - 20 \right] \quad \dots(i)$$

in second case,
$$\frac{60-30}{t} = K \left[\frac{60+30}{2} - 20 \right] \quad \dots(ii)$$

Dividing equation (i) by (ii) we get, $\frac{t}{2} = \frac{45}{25} = t = 9 \text{ min.}$

Practise Paper XI
Subject Physics (Theory)
Session 2023-24

Maximum marks: 70

Time allowed : 3 Hrs.

General Instructions:

- (i) There are 33 Questions in All. All questions are Compulsory.
- (ii) This question paper has five sections: section A, Section B, Section C, Section D and section E.
- (iii) All the sections are compulsory.
- (iv) Section A Contains 16 questions, 12 MCQ and four Assertion Reasoning based of 1 Mark each. Section B contains 5 questions of a marks each. Section C contains 7 questions and 3 marks each. Section D contains two case study based questions & 4 mark each + Section E contains three long answer type questions of 5 marks each.
- (v) There is no overall choice. However an internal choice has been provided in one question in section A, one question in section C, one question in each CBQ in section D and all three questions in section E. You have to attempt only one of the choices in such questions.

SECTION–A

1. A boy travels on a circular distance and radius R Starting from a point A he moves to a point B which is on the other end of the diameter AB. The ratio of the distance travelled to the displacement made by him is
 - (a) $\frac{\pi}{2}$
 - (b) π
 - (c) 2π
 - (d) 4π
2. When a body P moves on a circular path, the centripetal acceleration is
 - (a) directed Inwards from P to the centre of the circle.
 - (b) directed tangential to the circumference of the circle at P.
 - (c) directed perpendicular to the plane of the circle at P.
 - (d) directed outwards perpendicular to the circumference of the circle.
3. When the linear momentum & a particle is Increased by 1%, its kinetic energy increased by x% When the kinetic energy of the particle is increased

questi by 300%, Its linear momentum increases by y%.

- (a) 300 (b) 75 (c) 100 (d) 50

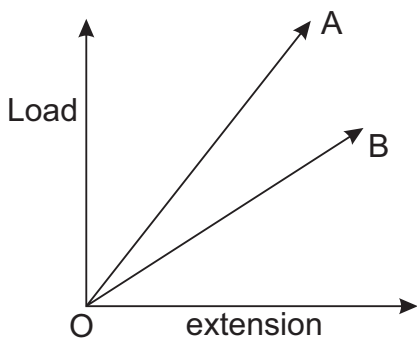
4. There is no atmosphere on the moon because
- (a) it is closer to the earth
(b) it revolves round the earth.
(c) It gets light from the sun
(d) the escape velocity and gas molecules is less than their root mean square velocity.
5. If a simple Pendulum oscillates with an amplitude of 50 mm velocity is and time period of as, its maximum
- (a) 0.10 m/s (b) 0.15 m/s (c) 0.8 m/s (d) 0.26 m/s
6. Angular momentum of the particle rotating with a central force is constant due to
- (a) Constant force (b) Constant Linear momentum
(c) Constant forque (d) Zero torque.
7. In the given figure, if the dimensions of the two whes are the same materials are different. Young's modulus is
- (a) More for A than B
(b) More for B than A
(c) Equal for A and B
(d) None of these
- 
8. Two wave of same frequency travelling in the same medium in opposite direction give rise to when superimposed
- (a) beats (b) harmonics
(c) standing wave (d) resonance.
9. The translational Kinetic energy of gas. molecule for mal & gas is
- (a) $\frac{3}{2}RT$ (b) $\frac{2}{3}KT$ (c) $\frac{RT}{2}$ (d) $\frac{3KT}{2}$

10. Find the value of λ so that the vector are to each other perpendicular
- (a) $\lambda = 4$ (b) $\lambda = 3$ (c) $\lambda = 10$ (d) $\lambda = 5$
11. A bullet fired into a fixed target loses half of its velocity after penetrating distance of 30m. How much further it will penetrate before coming to rest, assuming that it faces constant resistance to its motion?
- (a) 3 cm (b) 2 cm (c) 1.5 cm (d) 1 cm

12. The bob of simple pendulum is held in the horizontal position A. Assuming to loss of energy, speed & bob at the lowest position B, when hand is

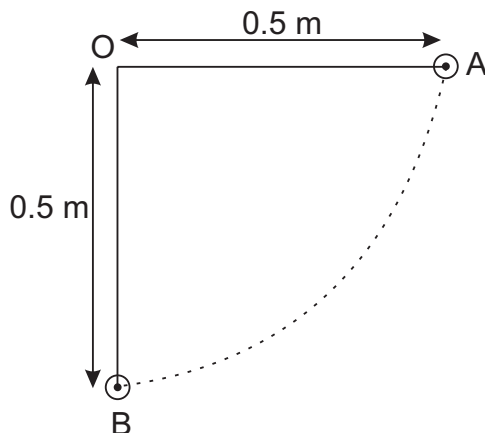

- (a) $\sqrt{9.8} \text{ m/s}$
 (b) 9.8 m/s
 (c) 0 m/s
 (d) $\sqrt{2 \times 9.8} \text{ m/s}$

For Questions 13 to 16, two statements one given one labelled Assertion (A) and other labelled Reason (R) Select the correct answer to these questions from the options as given below

(a) If both Assertion and Reason are true and Reason is correct explanation of Assertion

(b) If both Assertion and Reason are true but Reason is not correct explanation of Assertion.

(c) If Assertion is true but Reason is false

(d) If both Assertion & Reason are false

13. **Assertion (A):** It is difficult to move a cycle along the road, with brakes on.

Reason (R): sliding friction is greater than rolling friction.

14. **Assertion (A):** Specific heat of a gas in an adiabatic process is zero & in an isothermal process is infinite.

Reason (R): Specific heat of gas is directly proportional to change of heat in system and inversely proportional to change in temperature.

15. **Assertion (A):** In stationary wave, there is no transfer of energy.

Reason (R): The ratio of kinetic energy to energy is independent of its position. potential.

16. Assertion (A): The speed of sound in a gas is not affected by change in pressure provided the temperature of the gas remains constant.

Reason (R): The speed of sound is inversely proportional to the square root of the density of the gles.

SECTION-B

17. A mass of 200 kg is resting on a rough inclined plane of 30. If the coefficient of friction is to find. the least and the greatest forces acting parallel to the plane to keep the mass in equilibrium.

18. Two heavy spheres each of mass m kg and radius 0.1m apart on a horizontal table what is the gravitational force and potential at the midpoint of the line joining the centres of the spheres? Is an object placed at that point in equilibrium? If so, is the equilibrium stable or Unstable?

19. A ball is dropped vertically from rest at a height of 12 m. After striking the ground, it bounces to a height of h m. what fraction of kinetic energy does it lose on striking the ground? What are contact forces? Under what conditions will a body remain in equilibrium?

20. What are concurrent forces? Under what conditions will a body remain in equilibrium?

21. Two wires P and Q of same diameter are loaded as shown in the figure. The length of wire P is L m its Young's modulus is Y N/m² while length of wire Q is twice that of P its material has Young's modulus half that of P. compute the ratio of their elongation.

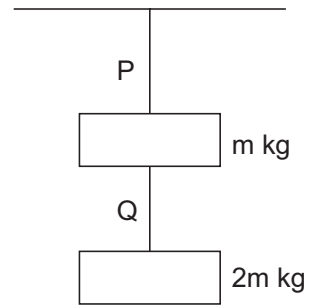

OR

An ideal monoatomic gas is taken round the Cycle ABCDA as shown calculate the work done during the cycle.

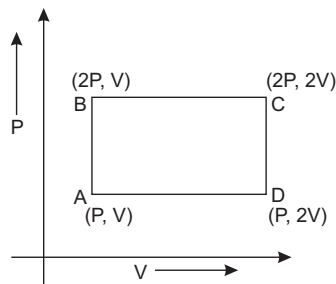

SECTION-C

22. The Identical springs of spring constant K are attached to a block of mass m and to the fixed Supports as shown below. Show that when the mass is displaced from its equilibrium position on the other side, it executes SHM. the period of oscillation.

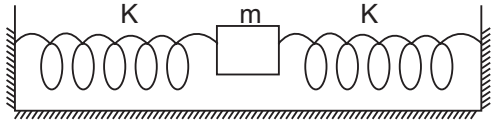

OR

Show that in a S.H.M, the phase difference between displacement and velocity is $\pi/2$ between displacement and acceleration is π .

23. There are few forces acting at a point P produced by strings as shown, which is at rest.

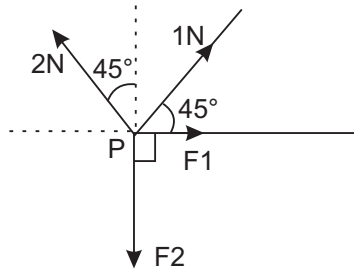

24. State Pascal's Law for fluids with the help of neat labelled diagram. Explain the Principle and work of hydraulic brakes.
25. Explain why:
- (i) a horse cannot pull a cart and run in empty space.
 - (ii) It is easier to pull a lawn mover than to push it.
 - (iii) porcelain objects wrapped in paper or straw before backing for transportation.
26. Show that in an elastic collision in one dimension, the relative velocity of approach before collision is equal to the relative velocity of separation after collision.
27. Distinguish with an illustration among free, forced and resonant oscillations. Identify name the thermodynamic processes 1,2,3 as shown in figure.
28. Identify name the thermodynamic processes 1, 2, 3 as shown in figure.

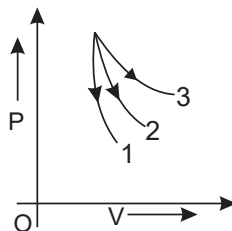

OR

Define thermal conduction and convection. How are these modes of transfer differ from thermal radiation.

SECTION-D

Read the following paragraph and answer the questions that follow.

29. A ball is projected from the ground level in vertically upward direction with an initial velocity u . The ball goes up to a maximum height H and start moving downward. Finally the ball falls back on the ground. It is given that motion of the ball under the action of gravity alone and effect of air resistance, if any, is negligible.

(i) The motion of ball projected with certain velocity in upward motion is example of what type of motion?

- (a) uniformly accelerated motion
- (b) uniformly retarded motion
- (c) Uniform motion
- (d) Non-uniform motion

(ii) What is the shape of position-time graph for entire motion of the ball?

- (a) straight line parallel to time axis
- (b) straight line Inclined at some angle with time axis.
- (c) circular
- (d) parabolic

(iii) what is the value of maximum height (H) upto which the ball goes?

- (a) $H = \frac{u^2}{2g}$ (b) $\frac{u^2}{g}$ (c) $\frac{2u^2}{g}$ (d) $\frac{u}{2g}$

(iv) What time does the ball take to reach the highest point during its motion?

- (a) $\frac{2u}{g}$ (b) $\frac{u}{2g}$ (c) $\frac{u}{g}$ (d) $\frac{u^2}{g}$

30. Ram was doing an experiment in physics lab to find co-efficient of viscosity of glycerine. In this experiment he drop lead shots in the tube filled with glycerine. Find the velocity of lead shots, then using stroke's law he found

the viscosity of glycerine The formula used by him was

$$\eta = \frac{2}{9} \frac{r^2}{v} (\rho - \sigma) g$$

Now, answer the following questions.

- (i) Stoke's force does not depend upon
- (a) radius of the object
 - (b) viscosity of the medium
 - (c) viscosity of the object
 - (d) acceleration due to gravity
- (ii) A steel ball is dropped in glycerine tube of long length, then
- (a) the ball stops after some time
 - (b) the speed of the ball keeps on increasing
 - (c) the ball attains constant velocity after some time
 - (d) none of the above
- (iii) The ratio of terminal velocities of two drops of radii R and $R/2$ is
- (a) $\frac{2u}{g}$
 - (b) $\frac{u}{2g}$
 - (c) $\frac{u}{g}$
 - (d) $\frac{u^2}{g}$
- (iv) S.I unit of coefficient of viscosity is
- (a) poise
 - (b) deca poise (dimensioner)
 - (c) dimensionless
 - (d) Erg

31. For two angles of projection 90° with same velocity u . Prove the following

- (i) Range is same
- (ii) Heights are in the ratio $1 : 1$
- (iii) If the range and maximum height are equal, the angle of projection is $\tan^{-1}(4)$

OR

- (a) Derive an expression for the acceleration of a body of mass ' m ' moving with a uniform speed in a circular path of radius r .

- (b) If two bodies have circular path of radius r_1 and r_2 time taken are the same. Find the ratio of the angular speed.
- (c) What is the minimum number of forces acting on an object in a plane that can produce a zero resultant force?
32. (a) Can Earth were to shrink suddenly (keeping the mass same). What would happen to the length of the day?
- (b) Prove that Gravitational force is conservative while frictional force is Non-conservative in nature.

OR

Prove that the angular momentum of a particle is twice the product of its mass and areal velocity. How does it lead to Kepler's second law of Planetary motion?

- (a) State and Prove Bernoulli's theorem
- (b) Using Bernoulli's theorem, explain how an aeroplane gets lift from air.

OR

- (a) What is surface energy? Prove that surface energy numerically equal to the surface tension.
- (b) Two narrow bores of diameters 3mm and 6mm are joined together to form a U-shaped tube open at both ends. If the U tube contains water, is the difference in its levels in two limbs of the tube? surface tension of water at the temperature and the experiment is 7.3×10^{-2} N/m. Take the angle of contact to be zero and density of water to be 1×10^3 kg/m³.

Practise Paper XI
Subject Physics (Theory)
Session 2023-24

Maximum marks: 70

Time allowed : 3 Hrs.

General Instructions:

- (i) There are 33 Questions in All. All questions are Compulsory.
- (ii) This question paper has five sections: section A, Section B, Section C, Section D and section E.
- (iii) All the sections are compulsory.
- (iv) Section A Contains 16 questions, 12 MCQ and four Assertion Reasoning based of 1 Mark each. Section B contains 5 questions of a marks each. Section C contains 7 questions and 3 marks each. Section D contains two case study based questions & 4 mark each + Section E contains three long answer type questions of 5 marks each.
- (v) There is no overall choice. However an internal choice has been provided in one question in section A, one question in section C, one question in each CBQ in section D and all three questions in section E. You have to attempt only one of the choices in such questions.
- (vi) Use of calculators is not allowed.

SECTION–A

1. Name the physical quantity which have dimensional formula $ML^{-1}T^{-1}$
 - (a) work
 - (b) moment of inertia
 - (c) moment of force
 - (d) impulse
2. At any instant, the velocity and acceleration of a particle moving along a straight line are v and a
 - (a) $v > 0, a > 0$
 - (b) $v > 0, a < 0$
 - (c) $v < 0, a < 0$
 - (d) $v < 0, a = 0$
3. A boy throws a ball with a velocity u at an angle θ and with the horizontal. At the same instant he starts running with uniform velocity to catch the ball before it hits the ground. To achieve this he should run with a velocity of:
 - (a) $u \cos \theta$
 - (b) $u \sin \theta$
 - (c) $u \cos \theta$
 - (d) $u^2 \cos \theta$

11. Four molecules of a gas have speeds 1, 2, 3 and 4 km/s. The value of the r.m.s. speed of the gas molecules is

- (a) $\frac{1}{2}\sqrt{15}$ km/s (b) $\frac{1}{2}\sqrt{10}$ km/s
(c) 2.5 km/s (d) $\sqrt{\frac{15}{2}}$ km/s

12. A transverse wave travels along x-axis. The particles of medium move

- (a) only along x-axis (b) only along y-axis
(c) only along z-axis (d) Either along y-axis or z-axis

For Questions 13 to 16, two statements are given -one labelled Assertion (A) and other labelled Reason (R). Select the correct answer to these questions from the options as given below.

- (a) If both Assertion and Reason are true and Reason is correct explanation of Assertion.
(b) If both Assertion and Reason are true but Reason is not the correct explanation of Assertion.
(c) If Assertion is true but Reason is false.
(d) If both Assertion and Reason are false.

13. **A:** When unit of measurement for a physical quantity is changed, its numerical value also changes.

R: Product of numerical value and unit of measurement for a physical quantity remains

14. **A:** Work done by a gas in isothermal expansion is more than the work done by the gas in the same expansion adiabatically.

R: Temperature remains constant in isothermal expansion and not in adiabatic expansion.

15. **A:** In simple harmonic motion, the velocity is maximum when the displacement is minimum.

R: Displacement and velocity of S.H.M. differ in phase by $\pi/2$.

16. **A:** Bullet fired from a pistol not the projectile.

R: In projectile motion body contains both horizontal and vertical acceleration.

SECTION B

17. Find the dimensions of $a \times b$ in the given equation $= \frac{a}{bx} - \frac{t^2}{b}$, where P is the power, x is the distance and t is the time.
18. Make the graphs for
- Position-time graph for uniformly accelerated motion.
 - Position-time graph for uniformly retarded motion.
 - Velocity-time graph for zero acceleration.
19. Discuss the variation of acceleration due to gravity with height above the earth's surface.

OR

Derive expression for orbital velocity of a satellite at a height h from the surface of the earth.

20. Discuss Newton's formula for velocity of sound in air. What correction was made to it by Laplace and why?
21. At what displacement, a particle in S.H.M. possesses half K.E. and half P.E.?

SECTION C

22. An object is moving with uniform acceleration 'a' and initial velocity 'u', derive velocity-time and displacement time relation for its motion using graphical method.
23. An object of mass m is raised from the surface of the earth to a height equal to the radius of the earth, that is, taken from a distance R to $2R$ from the centre of the earth. What is the gain in its potential energy?

OR

Obtain the expression of acceleration due to gravity, if an object is taken to a depth 'h' below the surface of earth

24. Calculate an expression for the work done by an ideal gas when it expands adiabatically from initial volume V_1 to final volume V_2 .
25. A cord of negligible mass is wound round the rim of a flywheel of mass 20 kg and radius 20 cm. A steady pull of 25 N is applied on the cord as shown in the adjacent figure.

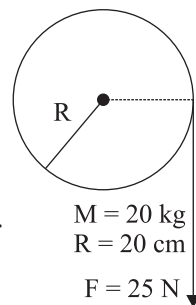

The flywheel is mounted on a horizontal axle with frictionless bearings.

- (a) Compute the angular acceleration of the wheel
 - (b) Find the work done by the pull, when 2 m of the cord is unwound
 - (c) Find also the kinetic energy of the wheel at this point. Assume that the wheel starts from rest.
26. Write Newton's formula for the speed of sound wave in air, What are the limitations of this 26 formula? Explain how Laplace corrected this formula and derive the expression for the corrected speed of sound in air.

OR

What are beats? Discuss the graphical method of formation of beats. Derive the expression for the beat frequency.

27. Show that when string fixed at its two ends vibrates in 1 loop, 2 loops, 3 loops and 4 loops then frequencies are in the ration 1:2:3:4.
28. Show the conservation of mechanical energy for freely falling body.

OR

- (a) What is (i) positive work (ii) negative work (iii) zero work.
- (b) Show that workdone due to conservative force does not depends on the path followed by the body.

SECTION D (Case Based Questions)

29. Frictional Force refers to the force generated by two surfaces that contact and slide against each other. In the case of an incline, the force of gravity is not perpendicular to the surface. As the angle of the incline increases, the normal force decreases, which decreases the frictional force? The incline can be raised until the object just begins to slide.

Imagine a situation in which, a block placed at the bottom of a rough inclined plane is projected up the plane with some initial speed along the incline. Coefficient of friction between block and the plane is μ . Block moves up the plane and comes to rest after time t_1 . Then it again starts sliding down and reaches the bottom in further time t_2 .

- (i) Which one of the following statements is incorrect?
 - (a) Frictional force opposes the relative motion.

- (b) Limiting value of static friction is directly proportional to normal reaction.
- (c) Rolling friction is smaller than sliding friction.
- (d) Coefficient of sliding friction has dimensions of length.
- (ii) Calculate retardation of block during upward motion.
- (a) $g \sin \theta - \mu g \cos \theta$ (b) $g \sin \theta + \mu g \cos \theta$
 (c) $g \cos \theta - \mu g \sin \theta$ (d) $g \cos \mu + \mu g \sin \theta$
- (iii) Calculate acceleration during downward motion.
- (a) $g \sin \theta - \mu g \cos \theta$ (b) $g \sin \theta + \mu g \cos \theta$
 (c) $g \cos \theta - \mu g \sin \theta$ (d) $g \cos \theta + \mu g \sin \theta$
- (v) Select the correct option.
- (a) $t_1 = t_2$ (b) $t_1 = t_2$
 (c) $t_1 = t_2$ (d) None of these

OR

Friction and perform _____

- (a) Positive work only
 (b) Zero work only
 (c) Negative work only
 (d) Positive, negative and zero work only
- 30.** The molecule of a monatomic gas has only three translational degrees of freedom. Thus, the average energy of a molecule at temperature T is $(3/2) KBT$. The total internal energy of a mole of such a gas is $U = (3/2) RT$. The molar specific heat at constant volume C_v is given by $C_v = dU/dT = (3/2) R$ For an ideal gas, $C_p - C_v = R$ Where C_p is the molar specific heat at constant pressure. Thus, $C_p = (5/2) R$
1. For monatomic rigid molecules ratio of specific heats γ is
 (a) $5/3$ (b) $7/5$ (c) $9/7$ (d) None of these
2. For diatomic molecules ratio of specific heats γ is
 (a) $5/3$ (b) $7/5$ (c) $9/7$ (d) None of these

3. For triatomic molecules (with 7 degrees of freedom) ratio of specific heats γ is
(a) $5/3$ (b) $7/5$ (c) $9/7$ (d) None of these
4. The value of C_p for diatomic molecules is
(a) $(5/2)R$ (b) $(7/2)R$ (c) $(6/2)R$ (d) $(9/2)R$

OR

Relation between pressure P and average Kinetic energy E per unit volume of gas is

- (a) $P = \frac{2}{3}E$ (b) $P = \frac{E}{3}$ (c) $P = \frac{3E}{2}$ (d) $P = 3E$

SECTION-E

31. (a) What is projectile? Obtain an expression for the maximum height and time of flight when it is projected at an angle θ with the horizontal.
(b) Prove that the maximum horizontal range is four times the maximum height attained by a projectile, which is fired along the required oblique direction

OR

- (a) Why are circular roads banked? Deduce an expression for the angle of banking.
(b) A 1000 kg car rounds a curve on a flat road of radius 50 m at a speed of 14 ms^{-1} . Will the car make the turn or will it skid if the coefficient of friction is 0.60? Justify.
32. (a) State and prove Bernoulli's theorem for the streamline flow of liquid in a tube of variable cross sectional area.
(b) A fully loaded Boeing aircraft has a mass of $3.3 \times 10^5 \text{ kg}$. Its total wing area is 500 m^2 . It is in level flight with a speed of 960 km/h. Estimate the fractional increase in the speed of the air on the upper surface of the wing relative to the lower surface. (density of air: $\rho = 1.2 \text{ kg m}^3$)

OR

- (a) What is excess pressure? Explain how it arises. Derive an expression of excess pressure inside a soap bubble.
- (b) A soap bubble is blown from a radius of 1 cm to 2 cm. Calculate the work done in doing so, if the surface tension of the soap solution is 42 dyne/cm.
- 33.** (a) What is simple harmonic motion. Show that the motion of a simple pendulum is for small oscillation is simple harmonic in nature.
- (b) A particle executes S.H.M. with a time period of 2 s and amplitude 20 cm. Calculate the minimum time required for the particle to move between two points 10 cm on either side of the mean position.

OR

- (a) What are stationary waves? Show that in case of stationary waves produced in a closed organ pipe, only odd harmonics are present.
- (b) Calculate the fundamental frequency of an organ pipe, of length 0.8 m open at both ends if the velocity of sound in air is 330 m/s. What will be the fundamental frequency if one end of the pipe is closed?

