

DIRECTORATE OF EDUCATION GNCT OF DELHI
ANNUAL SYLLABUS
CLASS XII
ENGINEERING GRAPHICS (Code 046)
(2026-27)

COURSE STRUCTURE

THEORY

Unit I: Isometric Projection of Solids

- (i) Construction of isometric scale showing main divisions of 10mm and smaller divisions of 1 mm, also showing the leading angles. Drawing helping view/s such as triangles, pentagon, hexagon, etc., using isometric scale.
- (ii) Isometric projection (drawn to isometric scale) of right regular solids such as cube; prisms and pyramids (triangular, square, pentagonal and hexagonal); cone; cylinder; sphere; hemisphere; when they are kept with their axis (a) perpendicular to HP / VP (b) parallel to HP and VP both.
- (iii) Combination of any two above mentioned solids keeping the base side parallel or perpendicular to HP/VP and placed centrally together (Axis of both the solids should not be given parallel to HP).

Note:

- 1. *Hidden* lines are not required in isometric projection.
- 2. *Indicate* the direction of viewing.

Unit II: Machine Drawing (as per SP46: 2003)

A. Drawing of machine parts

- (i) Drawing to full size scale with instruments.

(Internal choice will be given between any two of the following).

Introduction of threads: Standard profiles of screw threads - Square, Knuckle, B.S.W., Metric (external and internal); Bolts – Square head, hexagonal head; Nuts – Square head, Hexagonal head; Plain washer, Combination of nut and bolt with or without washer for assembling two parts together.

- (ii) Free-hand sketches

Conventional representation of external and internal threads; Types of studs – Plain stud, Square-neck stud, Collar stud; Screws (round-head, cheese-head, 90° flat counter sunk-head, hexagonal socket head and grub-screw); Types of rivets – Snap head, Pan head (without tapered neck), Flat head, 60° countersunk flat head.

Mid Term syllabus to be completed by 05 September 2026

MID TERM EXAMINATION

B. Assembly drawings and Dis-Assembly drawings

(Internal choice will be given between an Assembly drawing and a Dis-Assembly drawing).

1. Bearings
 - (i) Open-Bearing
 - (ii) Bush- Bearing

2. Rod-Joints
 - (i) Cotter-joints for round-rods (Sleeve and cotter joint)
 - (ii) Cotter-joints for square rods (Gib and cotter-joint)

3. Tie-rod and Pipe-joint
 - (i) Turnbuckle
 - (ii) Flange pipe joint

Note:

1. *In all Assembly drawings, half sectional front view will be asked. Side/End view or Top View/Plan will be drawn without section.*
2. *In all Dis-assembly drawings, only two orthographic views (one of the two views may be half in section or full in section) will be asked of any two parts only.*
3. (a) *In all sectional views, hidden lines/ edges are not to be shown.*
(b) *In all full views, hidden lines/edges are to be shown.*

NOTE: • Whole syllabus will be covered in Common Pre-Board Examination.

Annual syllabus to be completed by 15/12/2026

PRACTICALS

(i) To perform the following tasks (for One only) from the given views of the prescribed fifteen (15) machine blocks in **ANNEXURE-I**.

Value-Points

- | | |
|---|---|
| 1. Copy the given views | 1 |
| 2. Drawing the missing view with hidden lines | 2 |
| 3. Sketching the Isometric view without hidden edges | 5 |
| 4. To make the machine block of the above in three dimensions.
(Not to scale but approximately proportionately drawn with any medium i.e., Soap-cake, plasticine, clay, wax, floral foam brick (available with florists), etc. | 7 |

(ii) Computer Aided Design (CAD) – Project 10
Project file to be submitted on the simple solids or machine blocks as prescribed in part-I by using the CollabCAD software or any equivalent pertinent software.

- (iii) (a) Sessional work relating to machine blocks as prescribed. 3
(b) Viva-voce based on part-I and part-II 2

Total Marks 30

ACTIVITY

Industrial Visits (Two) to any industry/manufacturing plant/higher educational institute to acquaint the students with the present - day methods & technology for better conceptual understanding.

ANNEXURE -- 1

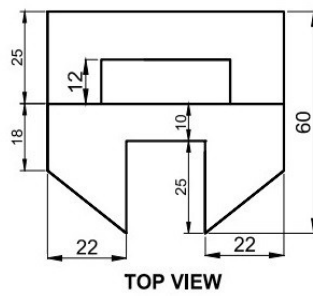
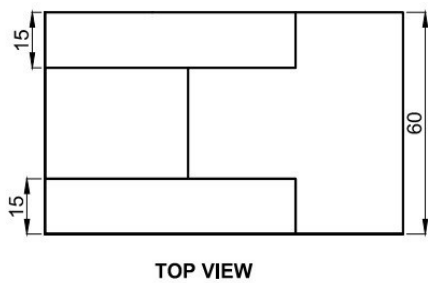
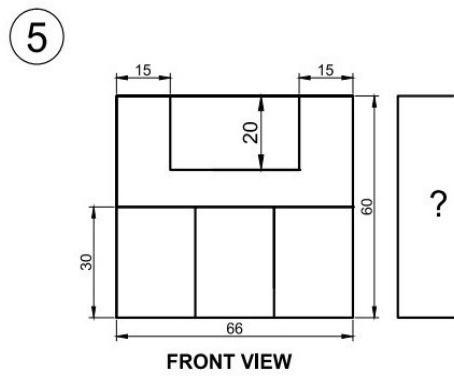
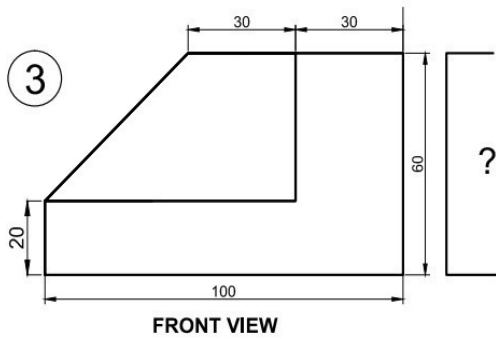
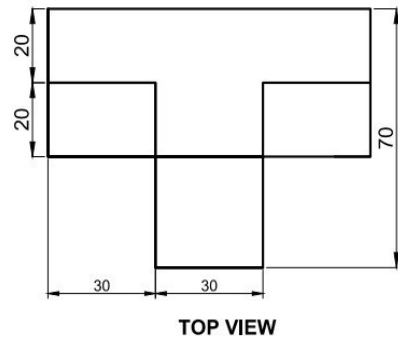
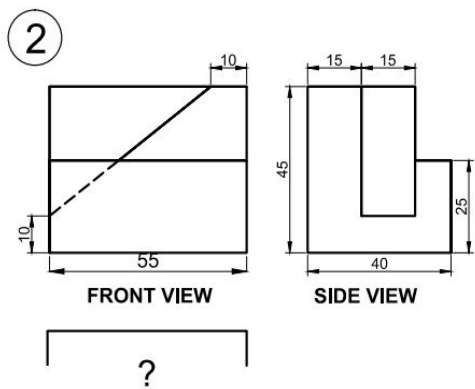
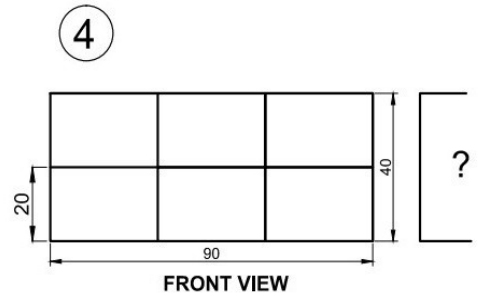
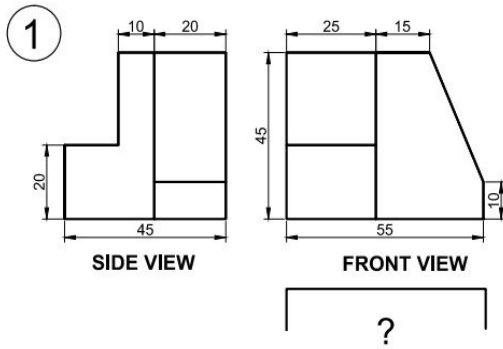

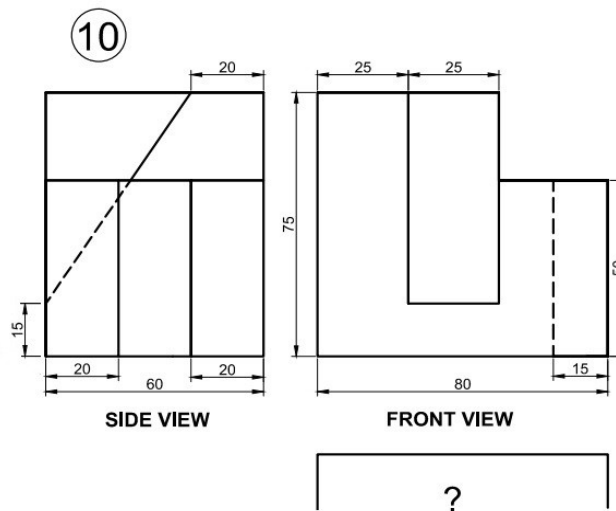
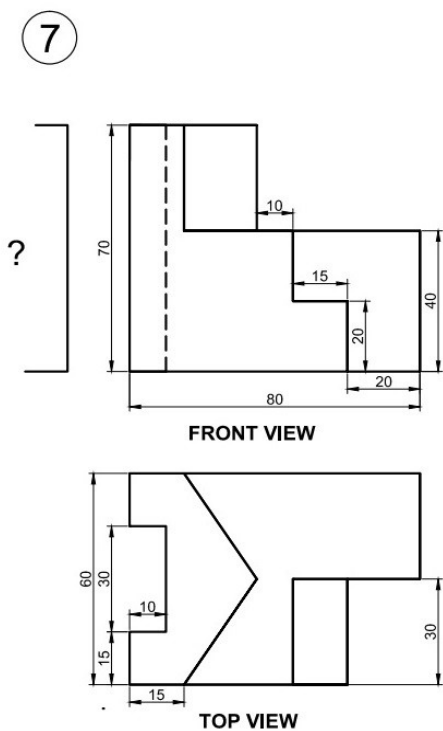
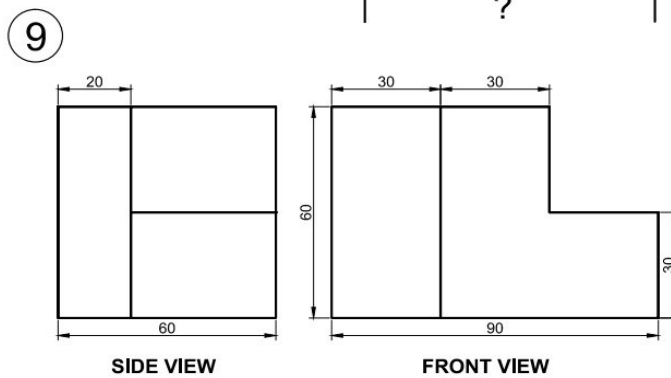
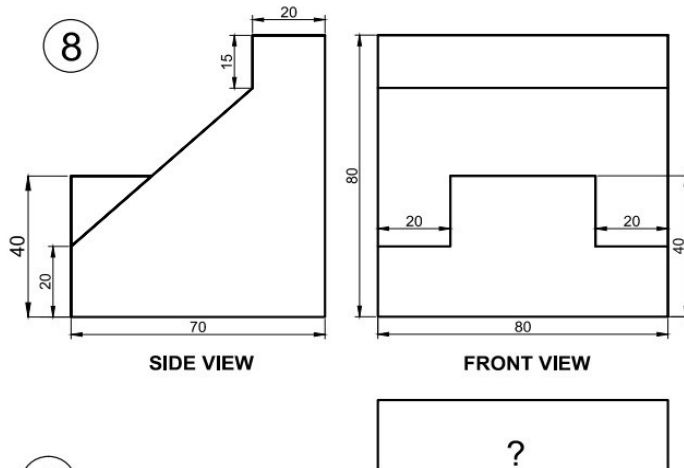
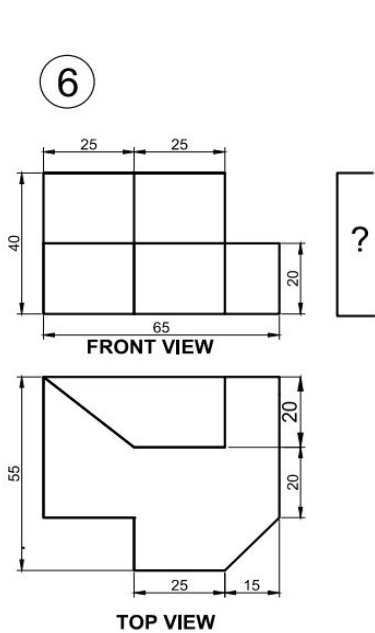

11

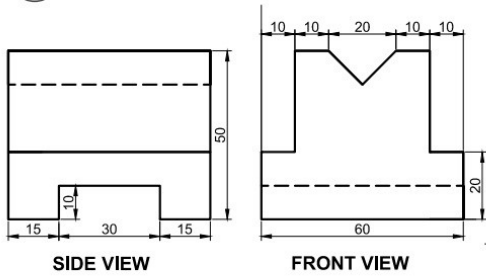

SIDE VIEW

FRONT VIEW

?

13

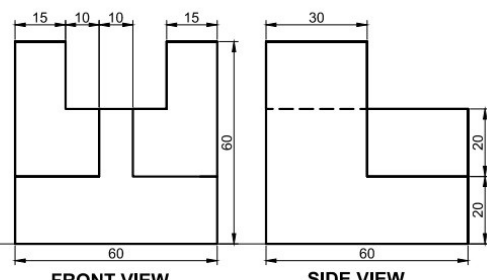

FRONT VIEW

SIDE VIEW

?

12

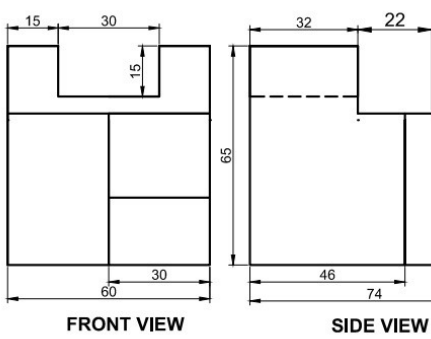

FRONT VIEW

SIDE VIEW

?

14

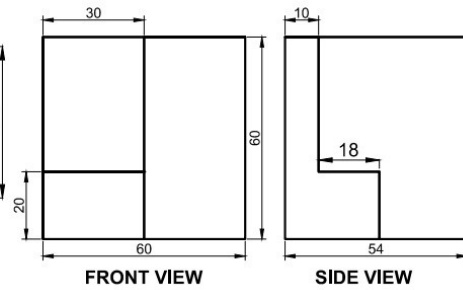

FRONT VIEW

SIDE VIEW

?

15

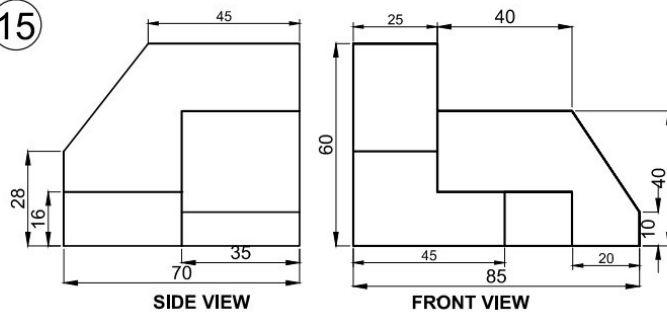

SIDE VIEW

FRONT VIEW

?